

CATALOGO PARTI DI RICAMBIO - PARTS CATALOG
CATALOGUE PIECES DE RECHANGE - ERSATZTEILKATALOG
CATALOGO PIEZAS DE REPUESTO

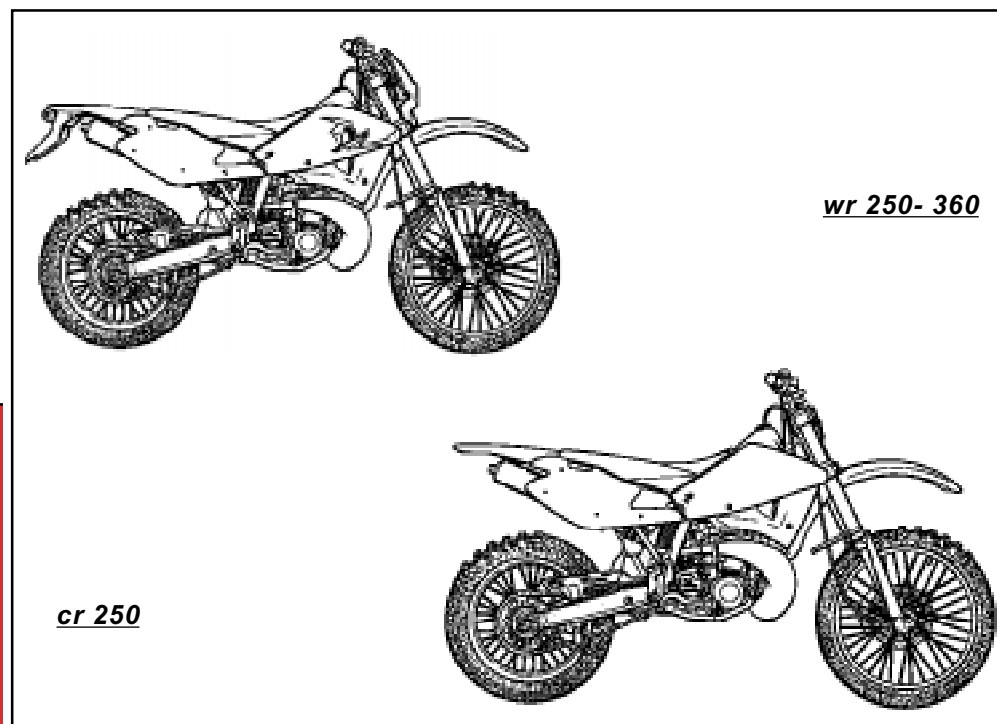

Part. N° 8000 97301

WR - CR 250 / 2001
WR 360 / 2001

INFORMAZIONI GENERALI

Il presente catalogo serve per richiedere con esattezza le parti di ricambio

Nelle ordinazioni indicare:

- 1) il numero di codice dei particolari seguito dalla descrizione;
- 2) il colore per i pezzi verniciati o comunque colorati;
- 3) il numero di matricola del motociclo, stampigliato sul canotto di sterzo.

Le indicazioni destra e sinistra si riferiscono ai lati del veicolo rispetto al senso di marcia.

GENERAL INFORMATION

The present spare parts list enables one to order exactly the right spare parts.

When ordering specify:

- 1) the part's code number followed by its description;
 - 2) indicate colour for painted or coloured parts;
 - 3) the motorcycle's serial number, stamped on the steering head.
- References to right and left apply to the vehicle in terms of its direction of movement.

INFORMATIONS GENERALES

Ca catalogue permet de commander correctement les pièces de rechange.

Les commandes doivent être passées en indiquant:

- 1) le numéro de code des pièces détachées suivi de leur description;
- 2) le couleur des pièces peintes ou colorés;
- 3) le matricule de la moto, estampillé sur la tige du guidon.

Droite et gauche sont les côtés du véhicule par rapport au sens de la marche.

ALLGEMEINE HINWEISE

Dieser Ersatzteilkatalog dient zur genauen Angabe der Teile bei Ersatzteilbestellungen.

Bei Ersatzbestellung ist folgendes anzugeben:

- 1) Die Bestellnummer der Ersatzteile mit der entsprechenden Beschreibung;
- 2) Farbe für lackierte und farbige Teile angeben;
- 3) Die Seriennummer des Motorrads, die am Lenkrohr eingepreßt ist.

Die Angaben rechts und links beziehen sich auf das Fahrzeug in Fahrrichtung.

INFORMACIONES GENERALES

El presente catálogo sirve para pedir con exactitud las partes de recambio.

En los pedidos se debe indicar:

- 1) el número de código de la parte y a continuación la descripción;
- 2) el color para las piezas barnizadas o coloreadas;
- 3) el número de matrícula de la motocicleta, estampado en el tubo de dirección.

Las indicaciones derecha e izquierda se refieren a los lados del vehículo respecto del sentido de marcha.

NOTE - LIST - NOTES - NOTE - NOTAS:

- A** : In alternativa - In alternative - En alternative
Wahlweise - En alternativa
- C** : Modello CR - CR model - Modèle CR - Modell CR
Modélo CR
- D** : In dotazione - To issue - En nécessaire
Ausrüstungsteile - En dotación
- E** : Ad esaurimento - To fell out - A' finir - Erschöpfung
A agotamiento
- F** : Fornire assieme - Supply unitedly - Fournir ensemble
Wird zusammen geliefert - Equipar juntos
- N** : Non fornito - Not supplied - Ne pas fournit
Keine Gelieferende - No equiparado
- R** : A richiesta - Upon request - Sur demande
Auf anfrage - Bajo pedido
- S** : Di serie - Supplied - De série - Standard - De serie
- W** : Modello WR - WR model - Modèle WR - Modell WR
Modélo WR
- U** : Modello WR/U.S.A. - WR/U.S.A. model - Modèle WR/
U.S.A. - Modell WR/U.S.A. - Modélo WR/U.S.A.
Nur für U.S.A. - Solo por U.S.A.
- X** : Non per U.S.A. - Not for U.S.A. - Ne pas pour U.S.A.
Keine für U.S.A. - No por U.S.A.
- Y** : Non per CR - Not for CR - Ne pas pour CR
Keine für CR - No por CR
- Z** : n° denti, number of teeth, numéro dents, Zähne nummer
número dientes

- A** : Austria, Austria, Autriche, Österreich, Austria
- AUS** : Australia, Australia, Australie, Australien, Australia
- B** : Belgio, Belgium, Belgique, Belgien, Bélgica
- BR** : Brasile, Brazil, Brasile, Brasilien, Brasil
- CDN** : Canada, Canada, Canada, Kanada, Canadá
- CH** : Svizzera, Switzerland, Suisse, Schweizer, Suiza
- D** : Germania, Germany, Allemagne, Deutschland, Alemania
- E** : Spagna, Spain, Espagne, Spanien, España
- F** : Francia, France, France, Frankreich, Francia
- FIN** : Finlandia, Finland, Finlande, Finnland, Finlandia
- GB** : Gran Bretagna, Great Britain, Grand Bretagne
Groos Britan, Gran Bretaña
- I** : Italia, Italy, Italie, Italien, Italia
- TA** : Tahiti, Tahiti, Tahiti, Tahiti, Tahiti
- USA** : Stati Uniti d'America, United States of America
Etats Unis d'Amérique,
Vereinigete Staaten von Amerika, Estados Unidos

Il n° di matricola iniziale del modello **WR 250/2001** è **ZCGH301AA1V001485**

Il n° di matricola iniziale del modello **CR 250/2001** è **ZCGH301AA1V050821**

Il n° di matricola iniziale del modello **WR 360/2001** è **ZCGH400AA1V001731**

The initial serial number for the **WR 250/2001** model is **ZCGH301AA1V001485**

The initial serial number for the **CR 250/2001** model is **ZCGH301AA1V050821**

The initial serial number for the **WR 360/2001** model is **ZCGH400AA1V001731**

Le matricule initial du modèle **WR 250/2001** est **ZCGH301AA1V001485**

Le matricule initial du modèle **CR 250/2001** est **ZCGH301AA1V050821**

Le matricule initial du modèle **WR 360/2001** est **ZCGH400AA1V001731**

Die Seriennummer des Modells **WR 250/2001** beginnt mit **ZCGH301AA1V001485**

Die Seriennummer des Modells **CR 250/2001** beginnt mit **ZCGH301AA1V050821**

Die Seriennummer des Modells **WR 360/2001** beginnt mit **ZCGH400AA1V001731**

El n° de matrícula inicial de la motocicleta **WR 250/2001** es **ZCGH301AA1V001485**

El n° de matrícula inicial de la motocicleta **CR 250/2001** es **ZCGH301AA1V050821**

El n° de matrícula inicial de la motocicleta **WR 360/2001** es **ZCGH400AA1V001731**

Dati indicativi soggetti a modifiche senza impegno di preavviso.

All data are subject to modification without prior notice.

Données indicatif sujet au modifications sans obligation de préavis.

Anderungen Vorbehalten.

Datos indicativos sujetos a modificaciones sin compromiso de preaviso.

Tavola Drawing Table Bild Tabla	Denominazione	Description	Designation	Bezeichnung	Denominacion	Pag. - Page - Page - Seite - Paja
1	ATTREZZI DI ASSISTENZA, MANUALI E CATALOGHI	SERVICE TOOLS, MANUALS AND CATALOGS	OUTILS D'ASSISTANCE, MANUELS ET CATALOGUES	HILFAUSRUSTUNG, HANDBUCH UND KATALOG	HERRAMIENTAS DE ASISTENCIA, MANUALES Y CATALOGOS	13
2	TESTA, CILINDRO, PISTONE, MANOVELLISMO (360)	CYLINDER HEAD, CYLINDER, PISTON, CRANKSHAFT (360)	CULASSE, CYLINDRE, PISTON, VILEBREQUIN (360)	ZYLINDERKOPF, ZYLINDER, KOLBEN, KURBELWELLE (360)	CULATA, CILINDRO, PISTON PALANCAS (360)	15
2A	TESTA, CILINDRO, PISTONE, MANOVELLISMO (250)	CYLINDER HEAD, CYLINDER, PISTON, CRANKSHAFT (250)	CULASSE, CYLINDRE, PISTON, VILEBREQUIN (250)	ZYLINDERKOPF, ZYLINDER, KOLBEN, KURBELWELLE (250)	CULATA, CILINDRO, PISTON PALANCAS (250)	21
3	H.T.S. (360)	H.T.S. (360)	H.T.S. (360)	H.T.S. (360)	H.T.S. (360)	27
3A	H.T.S. (250)	H.T.S. (250)	H.T.S. (250)	H.T.S. (250)	H.T.S. (250)	31
4	RAFFREDDAMENTO (360)	COOLING (360)	REFROIDISSEMENT (360)	WASSERKÜHLUNG (360)	ENFRIAMIENTO (360)	35
4A	RAFFREDDAMENTO (250)	COOLING (250)	REFROIDISSEMENT (250)	WASSERKÜHLUNG (250)	ENFRIAMIENTO (250)	37
5	BASAMENTO	CRANKCASE	CARTER	GEHAUSE	BANCADA	39
6	COPERCHI BASAMENTO (360)	CRANKCASE COVERS (360)	COUVERCLES CARTER (360)	GEHAUSEDECKEL (360)	TAPA BANCADA (360)	43
6A	COPERCHI BASAMENTO (250)	CRANKCASE COVERS (250)	COUVERCLES CARTER (250)	GEHAUSEDECKEL (250)	TAPA BANCADA (250)	45
7	AVVIAMENTO A PEDALE	KICK STARTER	PEDAL DE MISE EN MARCHÉ	ANLASSER	PUESTA EN MARCHA A PEDAL	47
8	FRIZIONE, TRASM. PRIMARIA	CLUTCH, PRIMARY DRIVE	EMBRAYAGE, TRANSMISS. PRIMARIE	KUPPLUNG, ERSTERANTRIEB	ENBRAGUE, TRANSM. PRIMARIA	51
8A	FRIZIONE, TRASM. PRIMARIA	CLUTCH, PRIMARY DRIVE	EMBRAYAGE, TRANSMISS. PRIMARIE	KUPPLUNG, ERSTERANTRIEB	ENBRAGUE, TRANSM. PRIMARIA	53
9	CAMBIO	TRANSMISSION	BOITE DE VITESSE	WECHSELGETRIEBE	CAMBIO	55
9A	CAMBIO	TRANSMISSION	BOITE DE VITESSE	WECHSELGETRIEBE	CAMBIO	59
10	COMANDO CAMBIO	SHIFTER	COMMANDE DE VITESSE	GANGSCHALTUNG	MANDO CAMBIO	63
10A	COMANDO CAMBIO	SHIFTER	COMMANDE DE VITESSE	GANGSCHALTUNG	MANDO CAMBIO	67
11	PARTE ELETTRICA	ELECTRIC PART	PARTIE ELECTRIQUES	ELEKTRISCHETEILE	PARTE ELECTR.	69
12	CARBURATORE	CARBURETOR	CARBURATEUR	VERGASER	CARBURADOR	71
12A	CARBURATORE	CARBURETOR	CARBURATEUR	VERGASER	CARBURADOR	75
13	FILTRO ARIA	AIR FILTER	FILTRE AIRE	AIRFILTER	FILTRO DE AIRE	79
14	TELAIO, PEDANE	FRAME, FOOT RESTS	CADRE, REPOSE PIEDS	RAHMEN, FUSSBRETT	BASTIDOR, REPOSAPIES	81
15	SOSPENSIONE ANTERIORE	FRONT FORK ASSEMBLY	SUSPENSION AVANT	VORDERTELESKOPGABEL	SUSPENSION DELANTERA	85
16	FORCELLONE	SWING ARM	FOURCHE	GABEL	HORQUILLA	91
16A	LEVARAGGI SOSPENSIONE POSTERIORE	REAR SUSPENSION LINKAGE	LEVIER SUSPENSION ARRIERE	HEBELWERK HINTERHAUFHANGUNG	PALANCA SUSPENSION TRASERA	95
16B	AMMORTIZZATORE POSTERIORE	REAR SUSPENSION	SUSPENSION ARRIÈRE	HINTERHAUFHANGUNG	SUSPENSION TRASERA	97



Tavola - Drawing - Table - Bild - Tabla

1

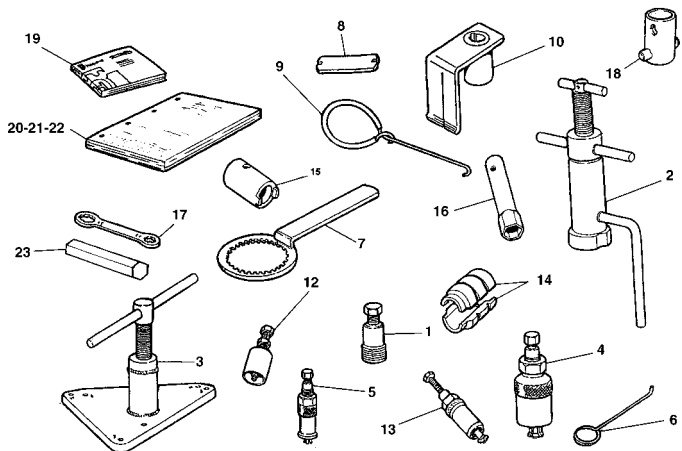

Pagina - Page - Page - Seite - Paja

13

Tavola - Drawing - Table - Bild - Tabla

2

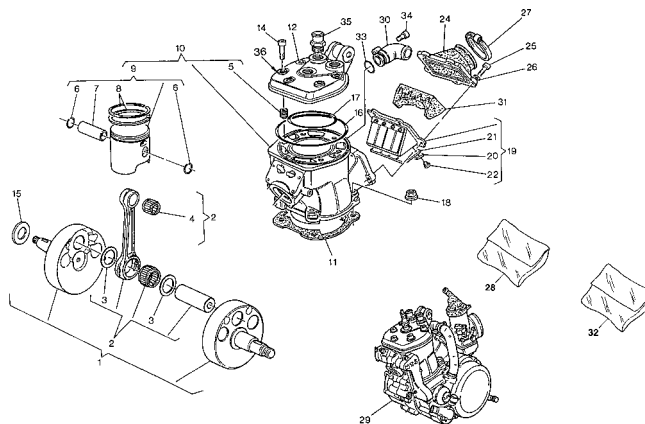

Pagina - Page - Page - Seite - Paja

15

Tavola - Drawing - Table - Bild - Tabla

2A

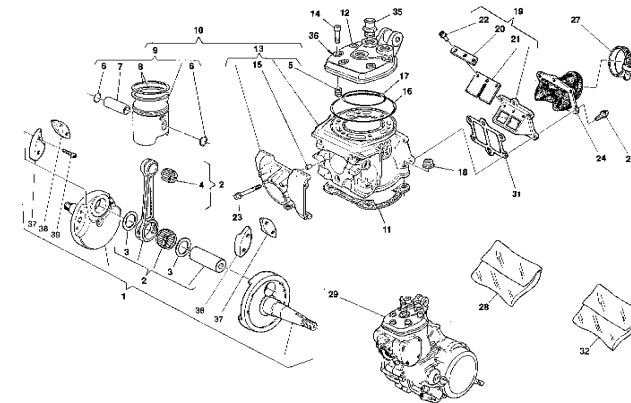

Pagina - Page - Page - Seite - Paja

21

Tavola - Drawing - Table - Bild - Tabla

3

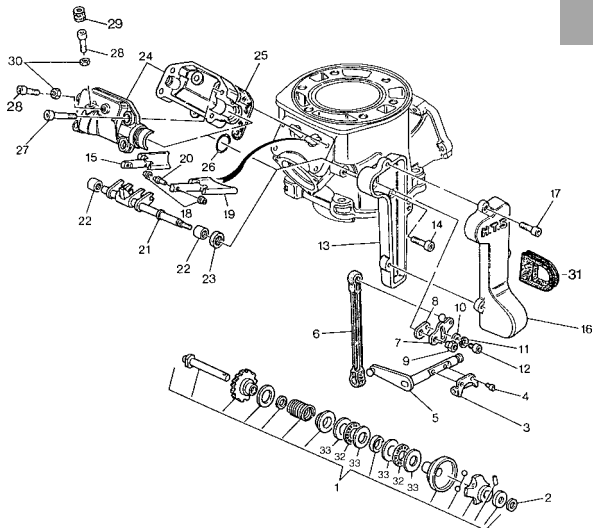

Pagina - Page - Page - Seite - Paja

27

Tavola - Drawing - Table - Bild - Tabla

3A

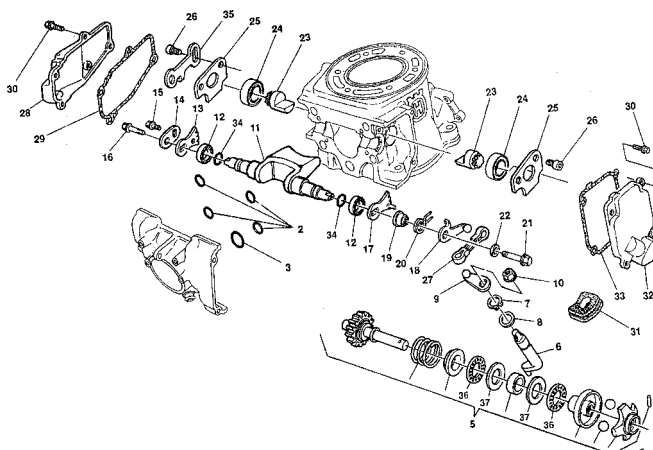

Pagina - Page - Page - Seite - Paja

31

Tavola - Drawing - Table - Bild - Tabla

4

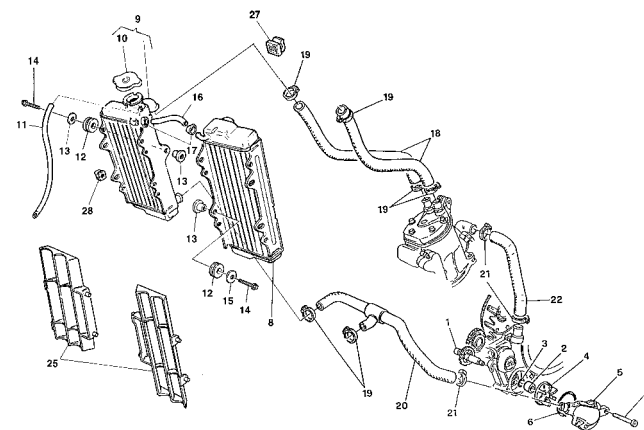

Pagina - Page - Page - Seite - Paja

35



WR - CR 250 / 2001
WR 360 / 2001

INDICE - INDEX - INDEX - INHALTSVERZEICHNIS - INDICE

Tavola - Drawing - Table - Bild - Tabla

4A

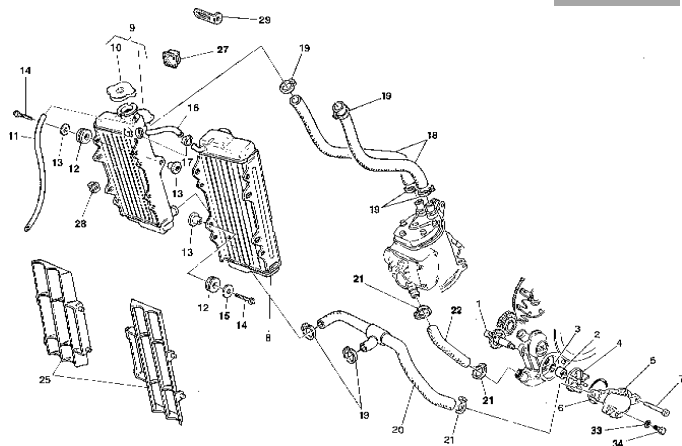

Pagina - Page - Page - Seite - Paja

37

Tavola - Drawing - Table - Bild - Tabla

5

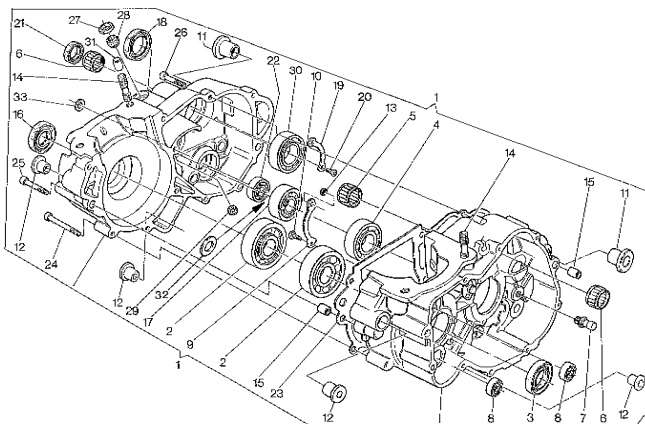

Pagina - Page - Page - Seite - Paja

39

Tavola - Drawing - Table - Bild - Tabla

6

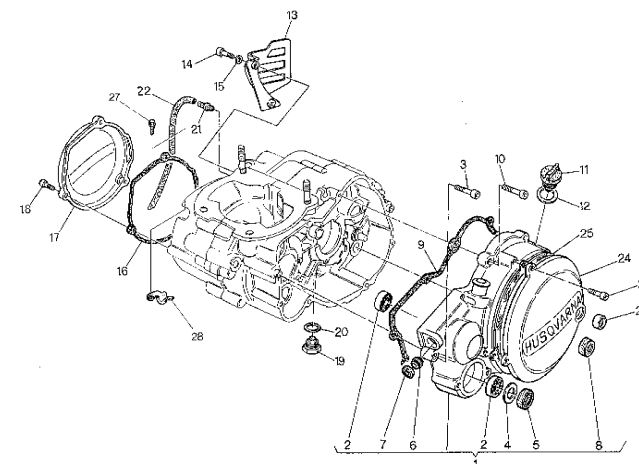

Pagina - Page - Page - Seite - Paja

43

Tavola - Drawing - Table - Bild - Tabla

6A

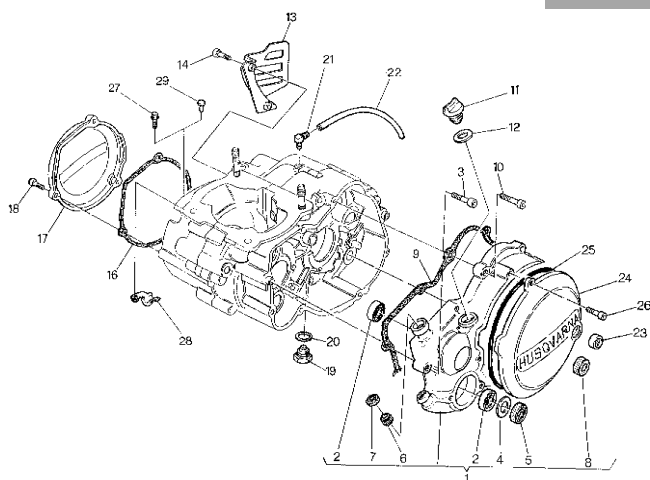

Pagina - Page - Page - Seite - Paja

45

Tavola - Drawing - Table - Bild - Tabla

7

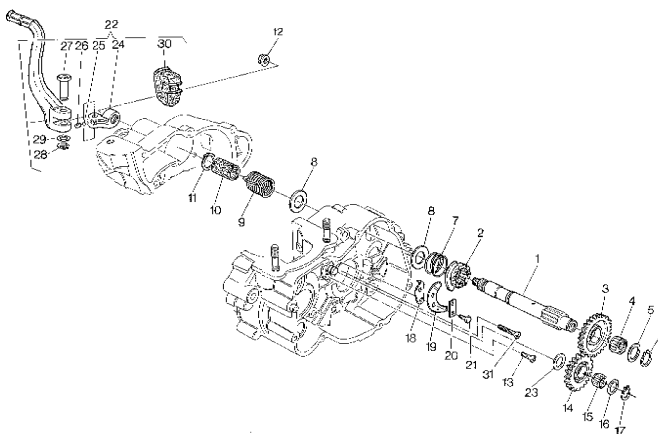

Pagina - Page - Page - Seite - Paja

47

Tavola - Drawing - Table - Bild - Tabla

8

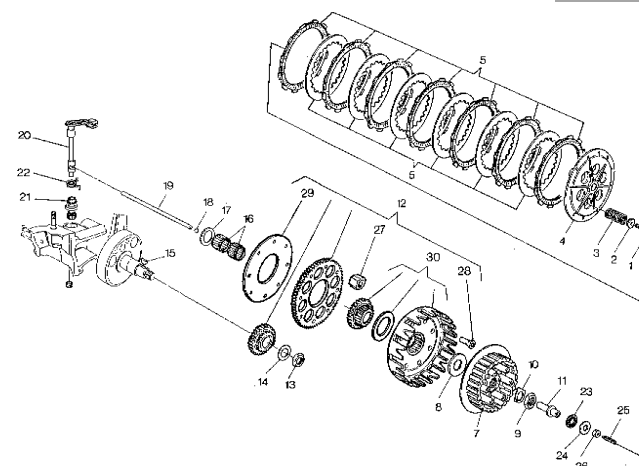

Pagina - Page - Page - Seite - Paja

51



Tavola - Drawing - Table - Bild - Tabla

8A

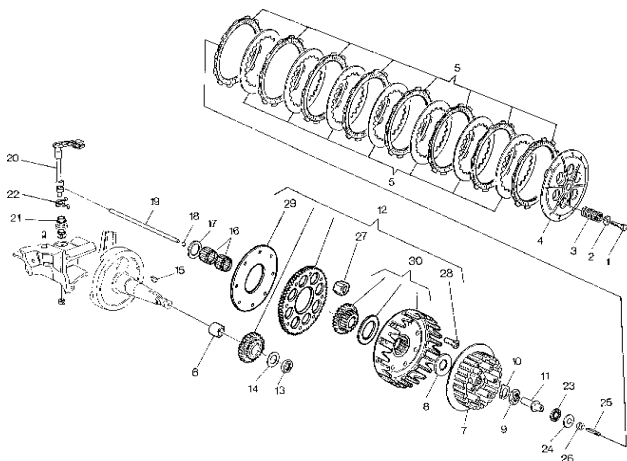

Pagina - Page - Page - Seite - Paja

53

Tavola - Drawing - Table - Bild - Tabla

9

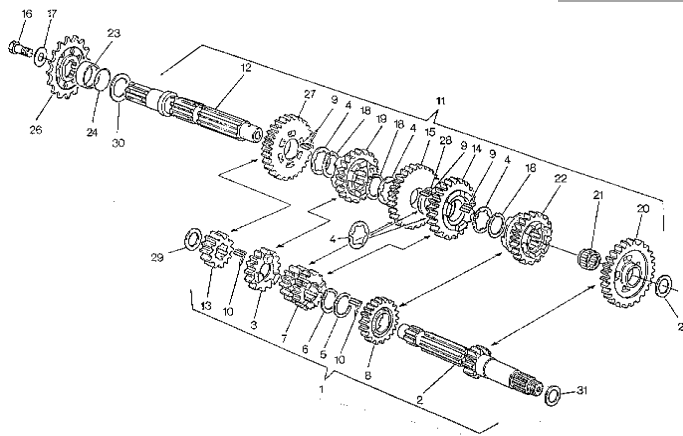

Pagina - Page - Page - Seite - Paja

55

Tavola - Drawing - Table - Bild - Tabla

9A

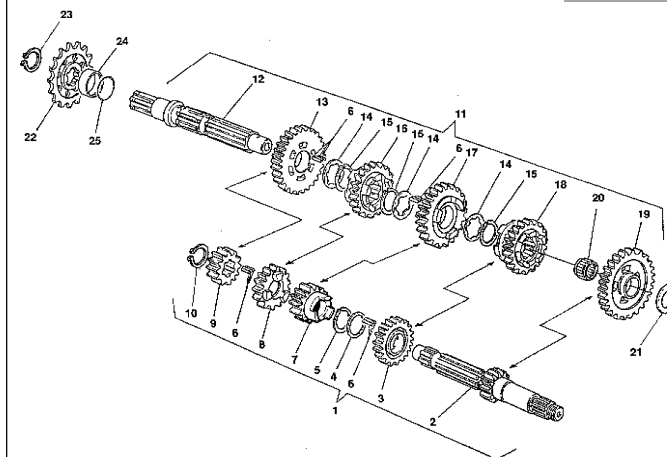

Pagina - Page - Page - Seite - Paja

59

Tavola - Drawing - Table - Bild - Tabla

10

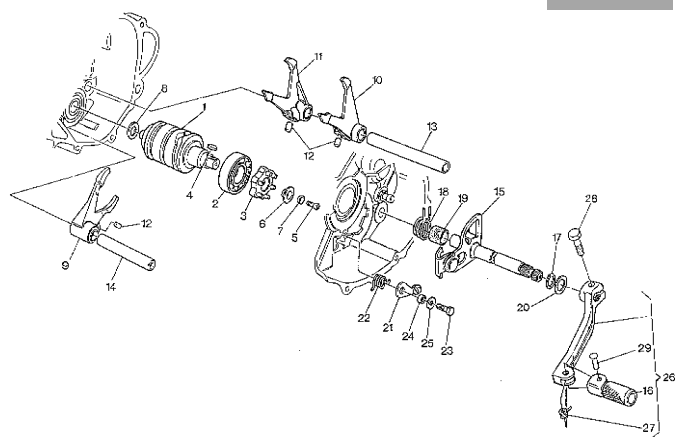

Pagina - Page - Page - Seite - Paja

63

Tavola - Drawing - Table - Bild - Tabla

10A

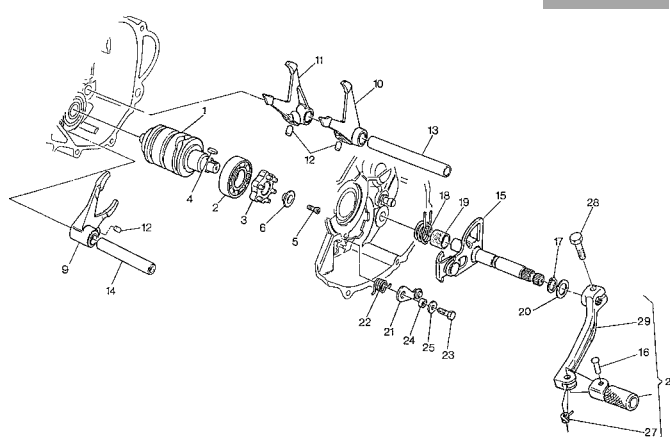

Pagina - Page - Page - Seite - Paja

67

Tavola - Drawing - Table - Bild - Tabla

11

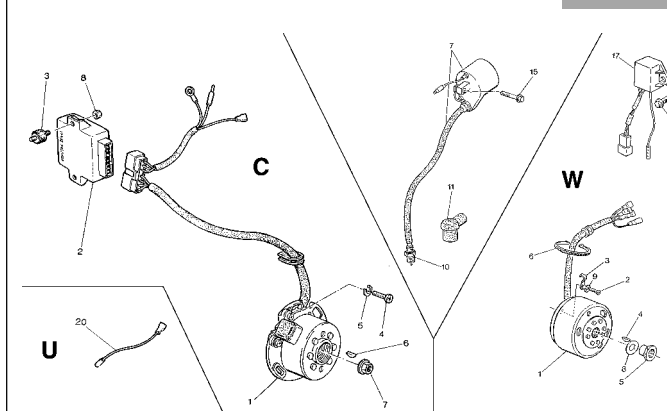

Pagina - Page - Page - Seite - Paja

69



WR - CR 250 / 2001
WR 360 / 2001

INDICE - INDEX - INDEX - INHALTSVERZEICHNIS - INDICE

Tavola - Drawing - Table - Bild - Tabla

12

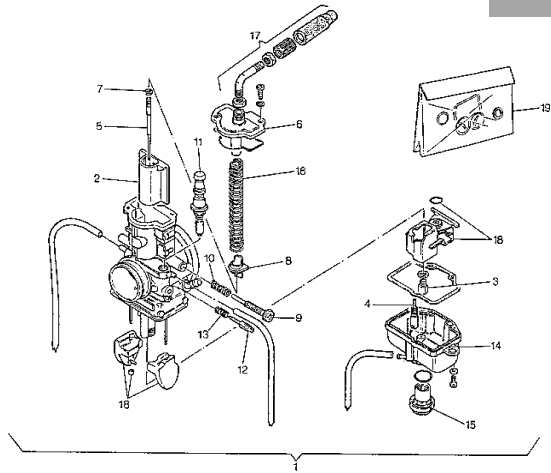

Pagina - Page - Page - Seite - Paja

71

Tavola - Drawing - Table - Bild - Tabla

12A

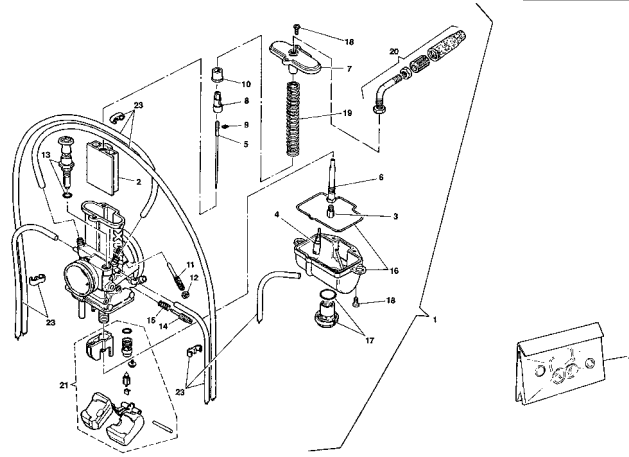

Pagina - Page - Page - Seite - Paja

75

Tavola - Drawing - Table - Bild - Tabla

13

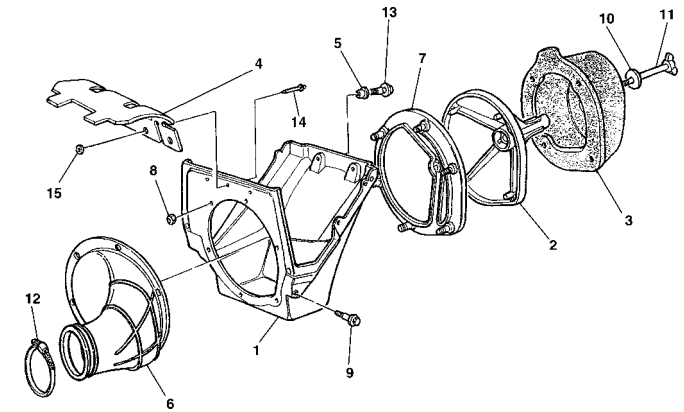

Pagina - Page - Page - Seite - Paja

79

Tavola - Drawing - Table - Bild - Tabla

14

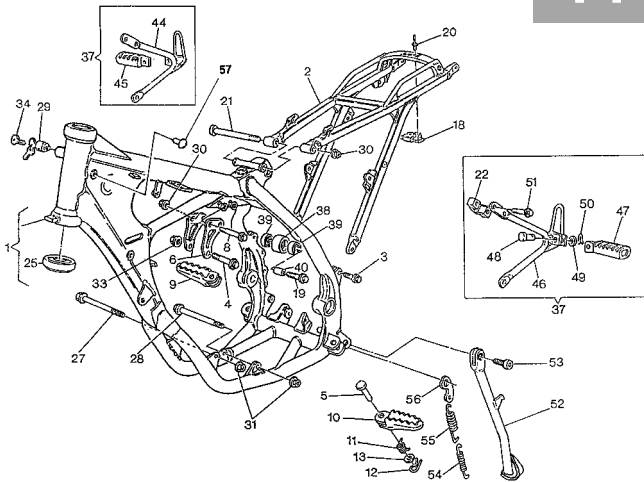

Pagina - Page - Page - Seite - Paja

81

Tavola - Drawing - Table - Bild - Tabla

15

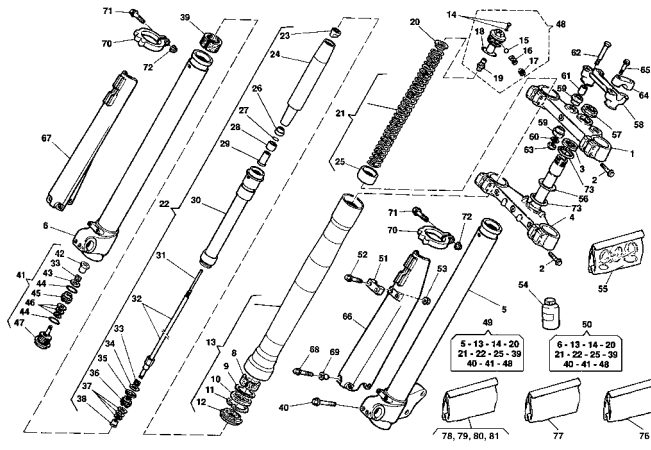

Pagina - Page - Page - Seite - Paja

85

Tavola - Drawing - Table - Bild - Tabla

16

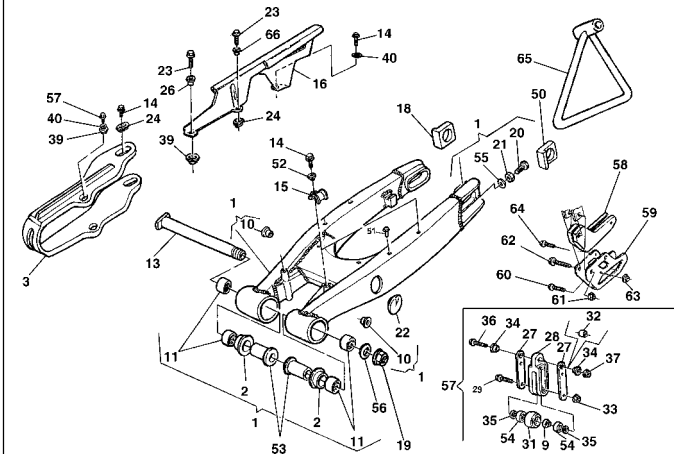

Pagina - Page - Page - Seite - Paja

91



Tavola - Drawing - Table - Bild - Tabla

16A

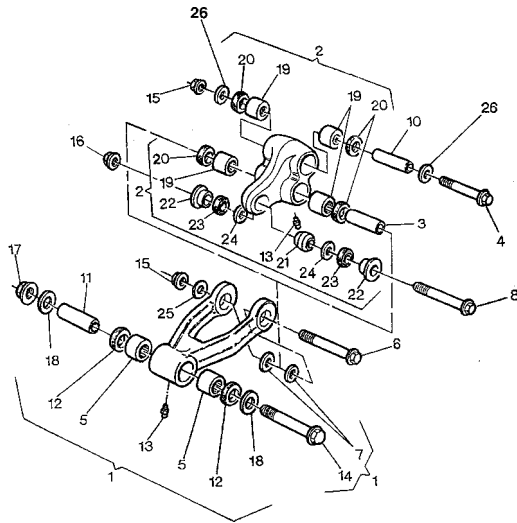

Pagina - Page - Page - Seite - Paja

95

Tavola - Drawing - Table - Bild - Tabla

16B

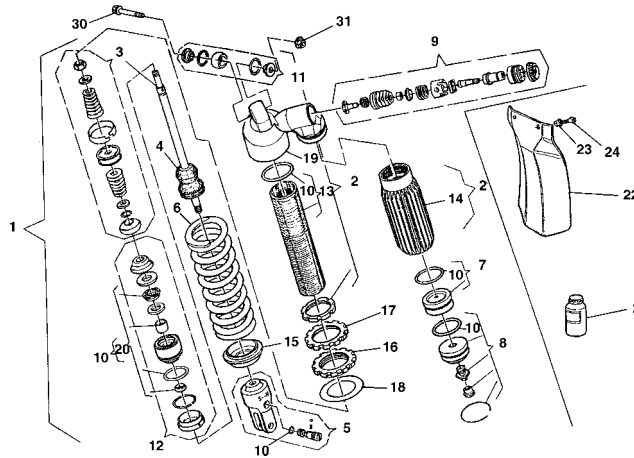

Pagina - Page - Page - Seite - Paja

97

Tavola - Drawing - Table - Bild - Tabla

17

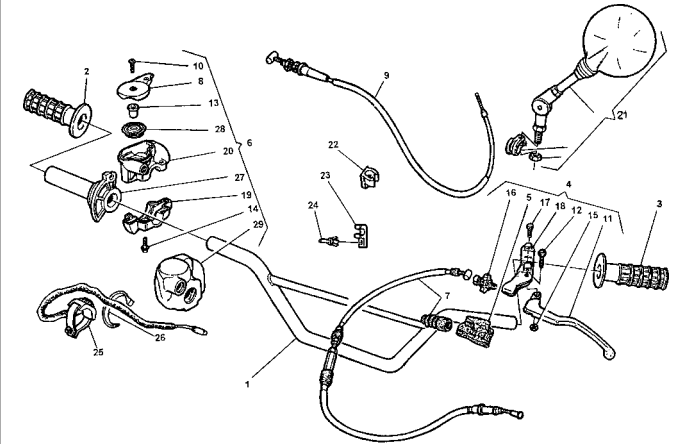

Pagina - Page - Page - Seite - Paja

101

Tavola - Drawing - Table - Bild - Tabla

18

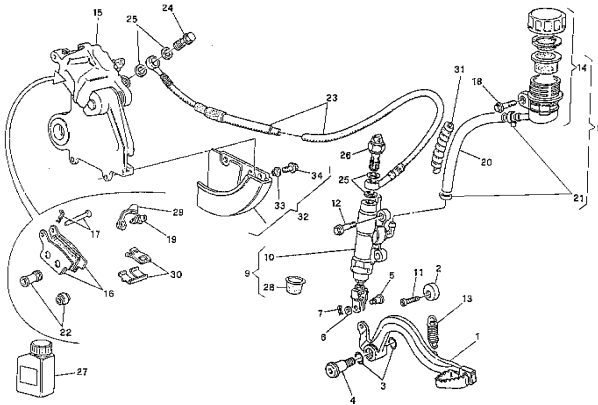

Pagina - Page - Page - Seite - Paja

105

Tavola - Drawing - Table - Bild - Tabla

19

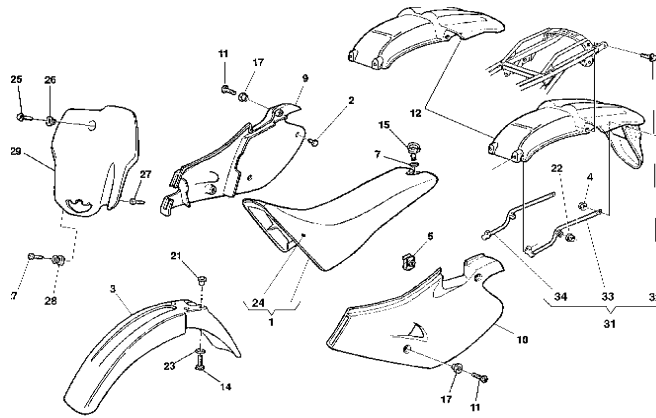

Pagina - Page - Page - Seite - Paja

109

Tavola - Drawing - Table - Bild - Tabla

20

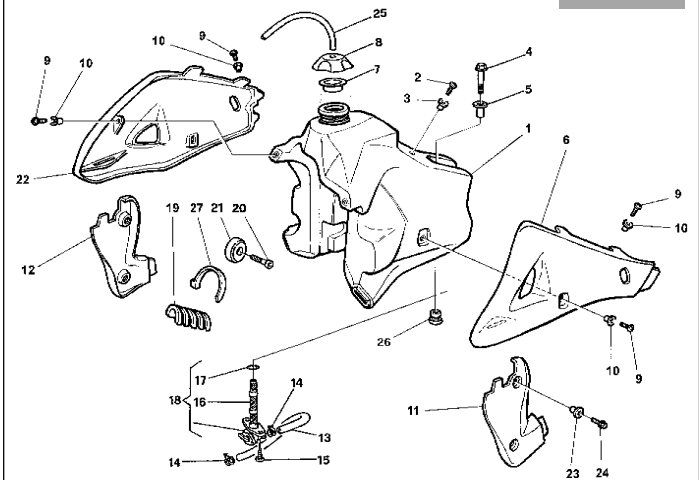

Pagina - Page - Page - Seite - Paja

111



WR - CR 250 / 2001
WR 360 / 2001

INDICE - INDEX - INDEX - INHALTSVERZEICHNIS - INDICE

Tavola - Drawing - Table - Bild - Tabla

21

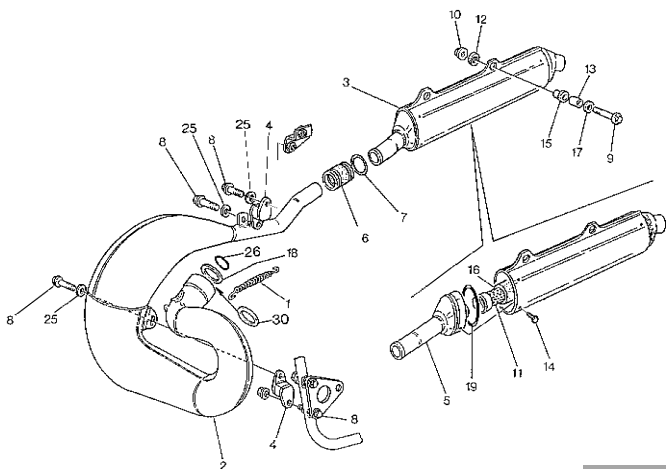

Pagina - Page - Page - Seite - Paja

113

Tavola - Drawing - Table - Bild - Tabla

22

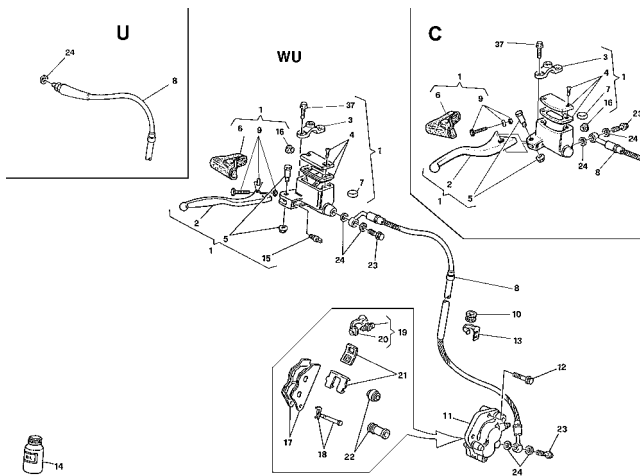

Pagina - Page - Page - Seite - Paja

115

Tavola - Drawing - Table - Bild - Tabla

22A

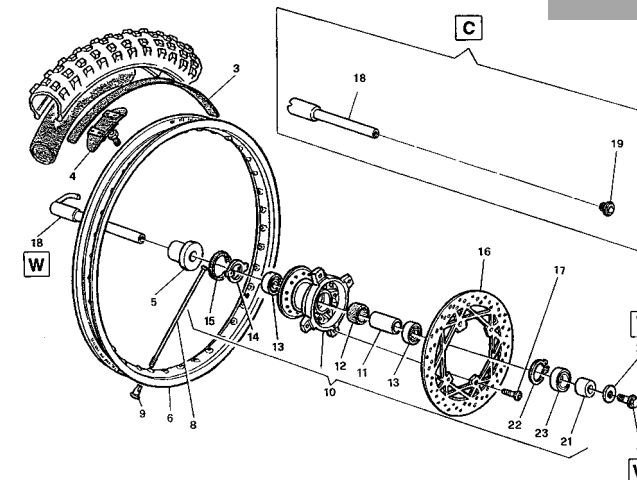

Pagina - Page - Page - Seite - Paja

119

Tavola - Drawing - Table - Bild - Tabla

23

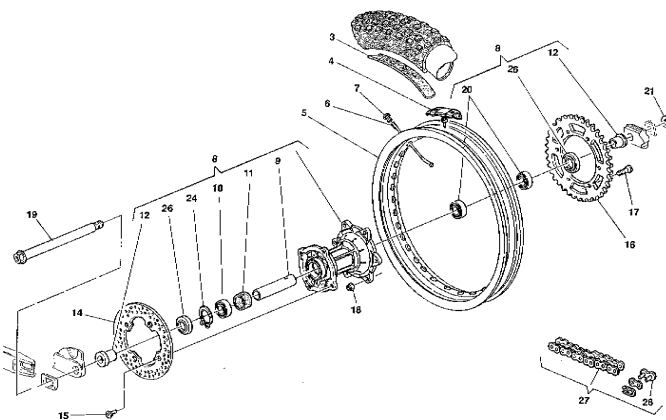

Pagina - Page - Page - Seite - Paja

121

Tavola - Drawing - Table - Bild - Tabla

24

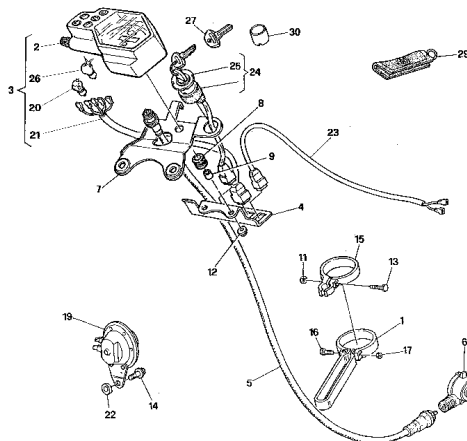

Pagina - Page - Page - Seite - Paja

125

Tavola - Drawing - Table - Bild - Tabla

25

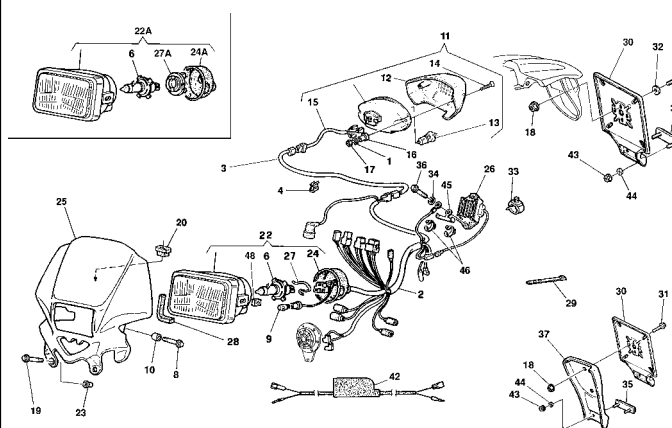

Pagina - Page - Page - Seite - Paja

127



WR - CR 250 / 2001
WR 360 / 2001

INDICE - INDEX - INDEX - INHALTSVERZEICHNIS - INDICE

Tavola - Drawing - Table - Bild - Tabla

26

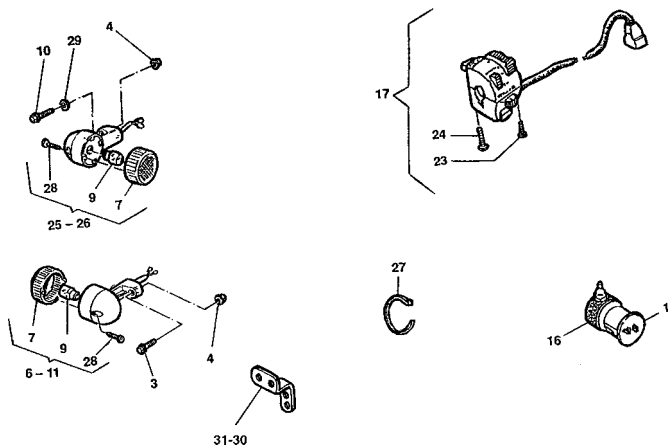

Pagina - Page - Page - Seite - Paja

131

Tavola - Drawing - Table - Bild - Tabla

27

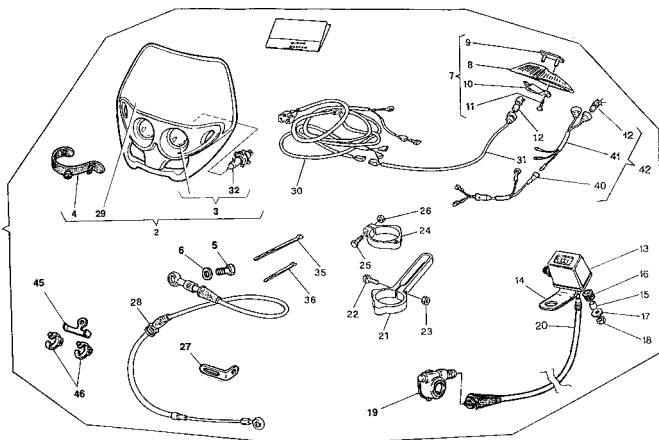

Pagina - Page - Page - Seite - Paja

133

Tavola - Drawing - Table - Bild - Tabla

28

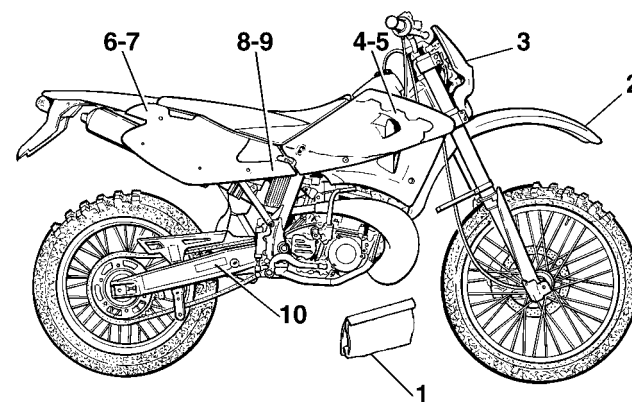

Pagina - Page - Page - Seite - Paja

137

Tavola - Drawing - Table - Bild - Tabla

29

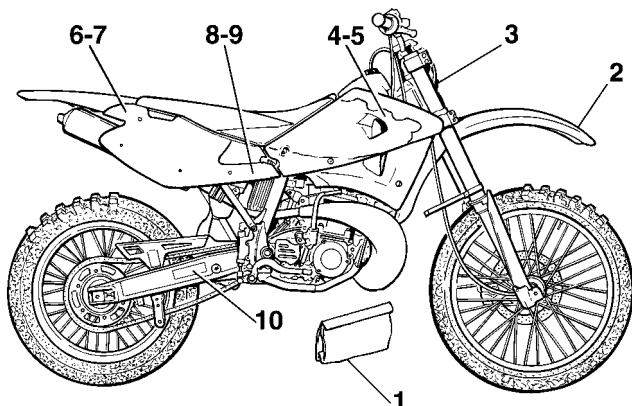

Pagina - Page - Page - Seite - Paja

139

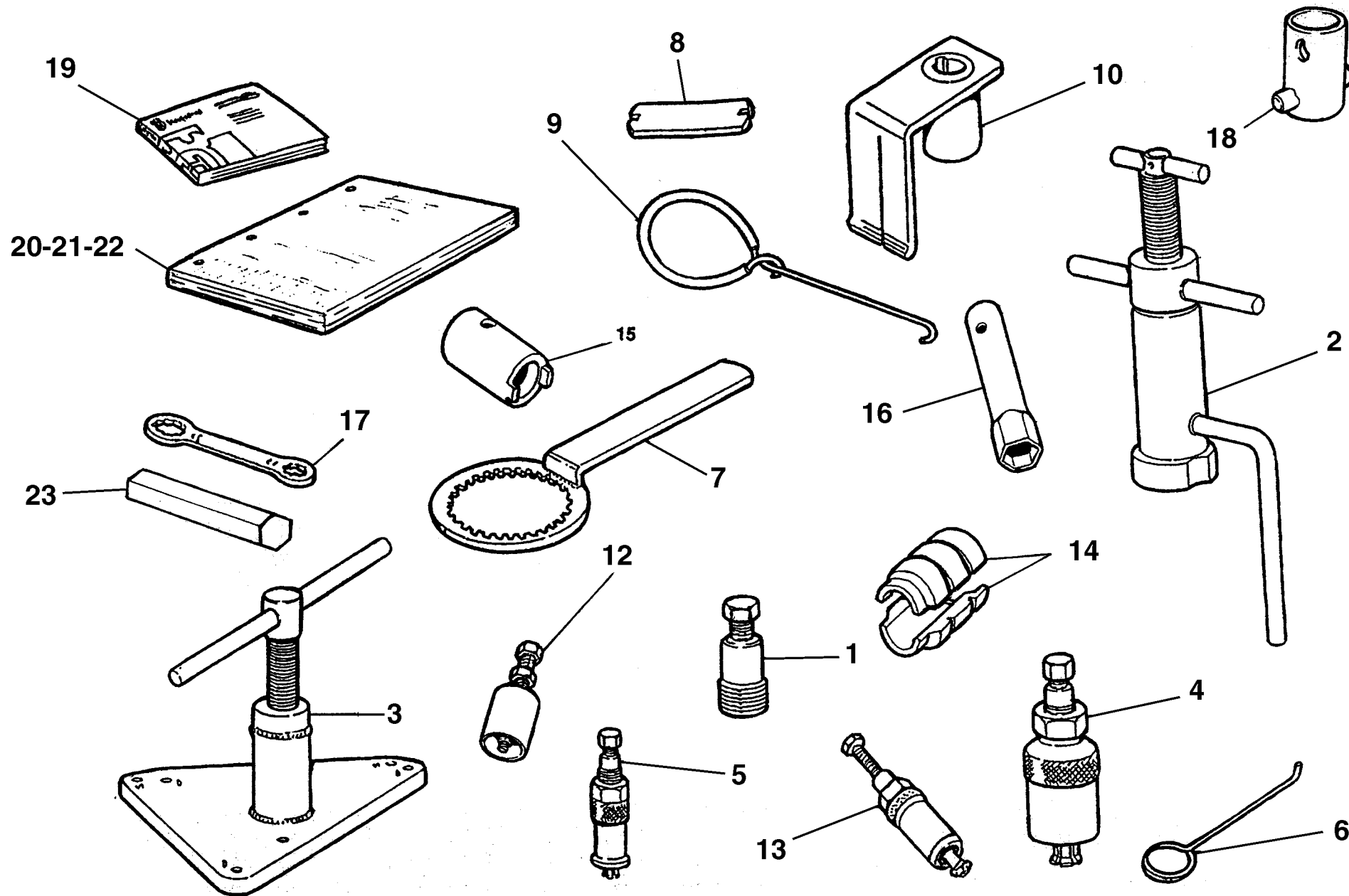



WR - CR 250/2001 ;
WR 360/2001

TAVOLA
DRAWING
TABLE
BILD
TABLA

1

ATTREZZI DI ASSISTENZA, MANUALI E CATALOGHI - SERVICE TOOLS, MANUALS AND CATALOGS - OUTILS
D'ASSISTANCE, MANUELS ET CATALOGUES - HILFAUSRUSTUNG, HANDBUCH UND KATALOG - HERRAMIENTAS DE
ASISTENCIA, MANUALES Y CATALOGOS

Note Notes Notas	Pos. No. Index Pos.	N. Cod. Code No. Nr. Code Code Nr N. Cod.	Q.tà Q.ty Q.te M.ge C.ad	DENOMINAZIONE	NAME	DESIGNATION	BESHREIBUNG	DENOMINACION	Validità Validity Validité Gültig Validez
W	1	8000 60516	1	Estrattore rotore acc.	Rotor puller	Extracteur rotor allumage	Auszieher Rotor zundung	Extractor rotor encendido	
C	1	8000 46613	1	Estrattore rotore acc.	Rotor puller	Extracteur rotor allumage	Auszieher Rotor zundung	Extractor rotor encendido	
	2	8000 58256	1	Attrezzo mont. alb. motore nel carter sx.	Installing tool. crankshaft left	Outil pour montage vilebrequin dans le demicarter G.	Werkzeug für Mont. Motorwelle im linken Kurbelgehäuse	Herramienta mont. eje motor en el carter izq.	
	3	8000 58258	1	Attrezzo separazione semicarter	Crankcase splitting tool	Outil dem. demicarter vilebreq.	Werkzeug um Halbgehaeuse	Herramienta semi-carter	
	4	8000 43720	1	Estrattore cuscinetto albero comando cambio	Bearing extractor	Extracteur pour roulement	Auszieher für rollenlayers	Extractor cojinete	
	5	8000 43824	1	Estratt. cuscinetto a rullini rinvio com. valvola e pompa acqua	Extracteur for roller bearing valve drive gear & water pump	Ext. pour roulement à aiguilles renvoi com.soup.-pompe eau	Abzie.für Nadellager Vorgelege Ventil wasserpumpelagerung	Extractor cojinete de rulos mando valvola y bomba agua	
	6	8000 46412	1	Attrezzo controllo dist. valvola di scarico e pistone (360)	Control tool valve (360)	Outil controle soupape (360)	Kontrollwerkzeug Abstand ventil (360)	Herramienta control valvula (360)	
	7	8000 39524	1	Chiave blocc. mozzo frizione	Clutch hub retaining wrench	Cléf arret moyeau embrayage	Halterungsschlüssel der	Llave bloquear cubo fricción	
	8	1519 88201	1	Chiave fiss. nipples	Wrench for nipples	Clé pour nipples	Nippelschlüssel	Llave fijacion niples	
	9	1519 84701	1	Gancio per molle	Hook	Crochet	Haken	Gancho	
W	10	8000 75578	1	Attrezzo controllo fase acc.	Ignition control tool	Outil Pour surveillance allumage	Werkzeug kontr. der zundungl	Herramientas control fase encendido	
C	10	8000 75579	1	Attrezzo controllo fase acc.	Ignition control tool	Outil Pour surveillance allumage	Werkzeug kontr. der zundungl	Herramientas control fase encendido	
	12	8000 90659	1	Attrezzo valvola Booster (250)	Booster installing tool (250)	Outil montage Booster (250)	Werkzeug mont. Booster (250)	Herram. mont. Booster (250)	
	13	8000 43823	1	Estrattore Cuscinetto	Needle bearing extractor	Extracteur pour roulement	Auszieher für Nadelkäfig	Extractor cojinete	
	14	8000 91288	1	Introduttore MIM	Jaw	Machoire	Zusatzbacke	Tenaza	
	15	8000 91289	1	Attrezzo blocca cartuccia	Pumping retainer	Arret pompage	Klammer pumpen	Broche bombeadora	
	16	8000 70836	1	Chiave candela	Spark plug wrench	Cléf bougie	Zündkerzeschlüssel	Llave bujia	
	17	8000 66802	1	Chiave poligonale	Box wrench	Clé polygonale	Sechskantschlüssel	Llave poligonal	
CD	18	8000 96997	1	Chiave perno ruota anteriore	Front wheel axle wrench	Cléf pivot roue avant	Vorterrad bolzen schlüssel	Llave perno rueda delantera	
D	19	8000 97299	1	Libretto uso e manutenzione	Owner's manual	Emploi d'entretien	Betriebsanleitung	Manual uso y mantenimiento	
R	20	8000 97300	1	Manuale di officina	Workshop manual	Manuel d'atelier	Werkstatthandbuch	Manual de Oficina	
D	21	8000 97831	1	Catalogo "KIT RACING"	"RACING KIT " catalog	Catalogue "KIT RACING"	"RACING KIT " katalog	Catalogo "KIT RACING"	
R	22	8000 97301	1	Catalogo "PARTI DI RICAMBIO"	"SPARE PARTS" catalog	Catalogue "PIECES DE RECHANGE"	ERSATZTEILKATALOG	Catalogo "PIEZAS DE REPUESTO"	
CD	23	8000 56920	1	Chiave esagonale per vite perno ruota anteriore	Front wheel axle screw Allen wrench	Clef à douille pour vis de pivot roue avant	Sechs Kantschlüssel für Vorderradbolzen schraube	Llave hexagonal por tornillo perno rueda delantera	

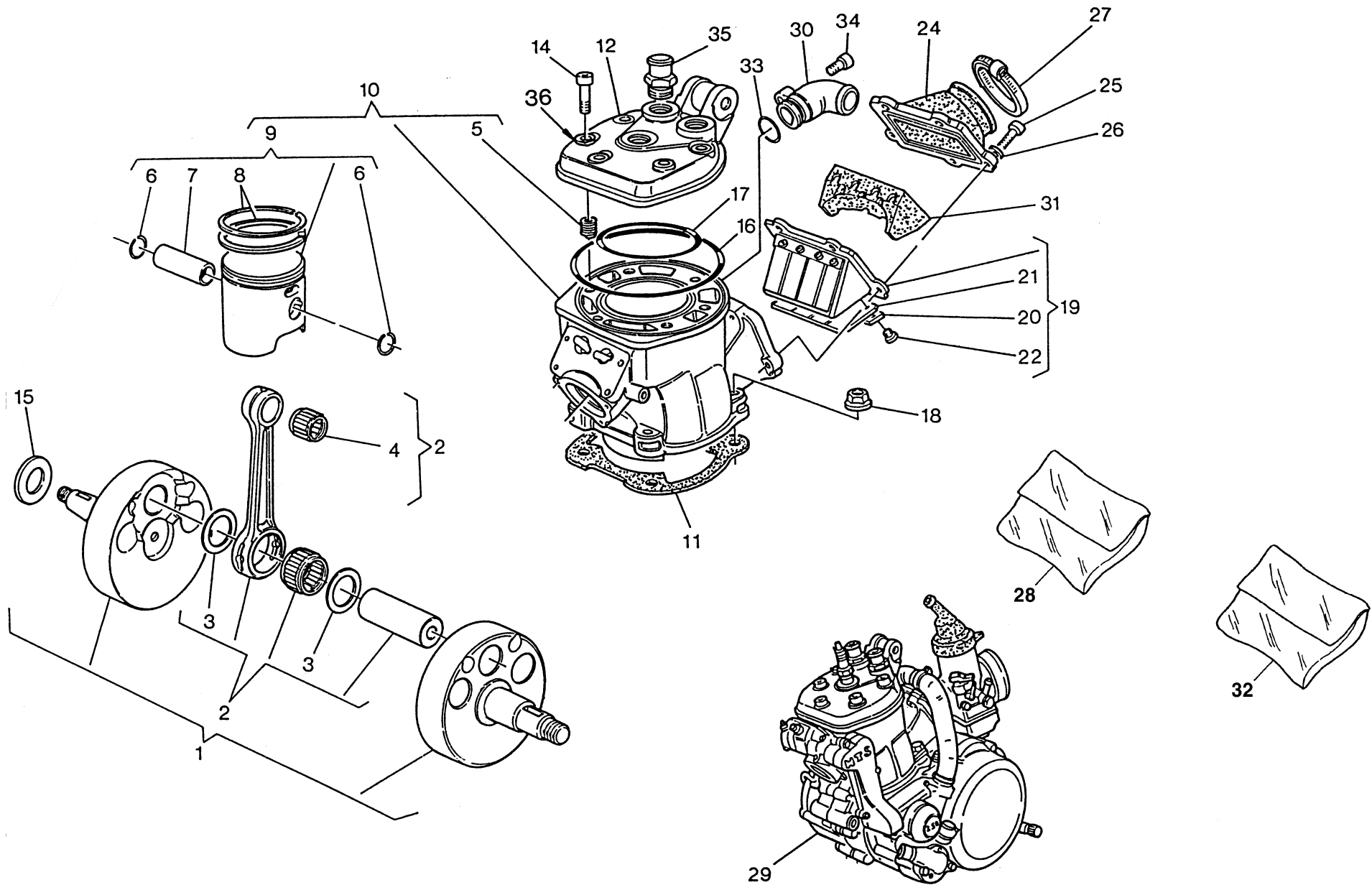



WR 360/2001

TAVOLA
DRAWING
TABLE
BILD
TABLA

2

**TESTA, CILINDRO, PISTONE, MANOVELLISMO - CYLINDER HEAD, CYLINDER, PISTON, CRANKSHAFT
CULASSE, CYLINDRE, PISTON, VILEBREQUIN - ZYLINDERKOPF, ZYLINDER, KOLBEN, KURBELWELLE
CULATA, CILINDRO, PISTON, PALANCAS**

Note Notes Notas	Pos. No. N. Index Pos.	N. Cod. Code No. Nr. Code Code Nr N. Cod.	Q.tà Q.ty Q.te M.ge C.ad	DENOMINAZIONE	NAME	DESIGNATION	BESHREIBUNG	DENOMINACION	Validità Validity Validité Gültig Validez
	1	8000 73505	1	Albero motore completo	Crankshaft assy	Vilebrequin compl.	Kurbewelle kpl.	Cigüeñal compl.	
	2	8000 63339	1	Biella completa	Connecting rod compl.	Bielle compl.	Pleuelstange kpl.	Biela motor completa	
	3	8000 50629	2	Rosetta di rasamento	Washer	Rondelle	Scheibe	Arandela	
H	4	8000 17826	1	Cuscinetto a rullini ($\varnothing 18 \times \varnothing 22 \times 22$ mm)	Needle bearing ($\varnothing 18 \times \varnothing 22 \times 22$ mm)	Roulement à aiguilles ($\varnothing 18 \times \varnothing 22 \times 22$ mm)	Nadelkäfig ($\varnothing 18 \times \varnothing 22 \times 22$ mm)	Cojinete de rodillos ($\varnothing 18 \times \varnothing 22 \times 22$ mm)	
	5	8A00 30729	6	Helicoil	Inserted thread	Filetage appliq	Gewindeinsatz	Fileteado aplicado	
	6	8000 70223	2	Anello di fermo	Stop ring	Bague d'arrêt	Haltering	Anillo de retención	
	7	8000 70222	1	Spinotto	Gudgeon	Axe	Bolzen	Perno	
	8	8000 63584	2	Segmento	Circlip	Segment	Kolbenring	Segmento	
	9		1	Pistone completo	Compl. piston	Piston complet	Kolbe, kpl.	Pistón completo	
	9	8000 63583/1	1	A - B ($\varnothing 77,935 \div 77,945$ mm)	A - B ($\varnothing 77,935 \div 77,945$ mm)	A - B ($\varnothing 77,935 \div 77,945$ mm)	A - B \varnothing ($77,935 \div 77,945$ mm)	A - B ($\varnothing 77,935 \div 77,945$ mm)	
	9	8000 63583/2	1	C - D ($\varnothing 77,945 \div 77,955$ mm)	C - D ($\varnothing 77,945 \div 77,955$ mm)	C - D ($\varnothing 77,945 \div 77,955$ mm)	C - D ($\varnothing 77,945 \div 77,955$ mm)	C - D ($\varnothing 77,945 \div 77,955$ mm)	
	9	8000 63583/3	1	E - F ($\varnothing 77,955 \div 77,965$ mm)	E - F ($\varnothing 77,955 \div 77,965$ mm)	E - F ($\varnothing 77,955 \div 77,965$ mm)	E - F ($\varnothing 77,955 \div 77,965$ mm)	E - F ($\varnothing 77,955 \div 77,965$ mm)	
	10	8000 87880	1	Cilindro completo	Cylinder assy	Cylindre compl.	Zylinder kpl.	Cilindro compl.	
	11	8000 68805	1	Guarnizione (0,3 mm)	Gasket (0,3 mm)	Garniture (0,3 mm)	Dichtung (0,3 mm)	Junta (0,3 mm)	
	11	8A00 68805	1	Guarnizione (0,4 mm)	Gasket (0,4 mm)	Garniture (0,4 mm)	Dichtung (0,4 mm)	Junta (0,4 mm)	
	11	8B00 68805	1	Guarnizione (0,5 mm)	Gasket (0,5 mm)	Garniture (0,5 mm)	Dichtung (0,5 mm)	Junta (0,5 mm)	
	11	8C00 68805	1	Guarnizione (0,6 mm)	Gasket (0,6 mm)	Garniture (0,6 mm)	Dichtung (0,6 mm)	Junta (0,6 mm)	
	11	8D00 68805	1	Guarnizione (0,8 mm)	Gasket (0,8 mm)	Garniture (0,8 mm)	Dichtung (0,8 mm)	Junta (0,8 mm)	
	12	8000 73356	1	Testa cilindro	Cylinder head	Culasse	Zylinderkopf	Cabeza cilindro	
	14	60N1 02558	6	Vite M8x35mm	Screw M8x35mm	Vis M8x35mm	Schraube M8x35mm	Tornillo M8x35mm	
	15	8A00 10350	1	Rosetta (0,3 mm)	Washer (0,3 mm)	Rondelle (0,3 mm)	Scheibe (0,3 mm)	Arandela (0,3 mm)	
	15	8B00 10350	1	Rosetta (0,4 mm)	Washer (0,4 mm)	Rondelle (0,4 mm)	Scheibe (0,4 mm)	Arandela (0,4 mm)	
	15	8C00 10350	1	Rosetta (0,5 mm)	Washer (0,5 mm)	Rondelle (0,5 mm)	Scheibe (0,5 mm)	Arandela (0,5 mm)	
	16	8B00 63593	1	Anello OR	O-Ring	Bague OR	O-Ring	Anillo OR	
	17	8000 63594	1	Anello OR	O-Ring	Bague OR	O-Ring	Anillo OR	
	18	8000 38624	4	Dado	Nut	Ecrou	Mutter	Tuerca	
	19	8B00 60278	1	Valvola aspirazione compl.	Inlet valve assy	Soupape d'aspiration compl.	Einlassventil kpl.	Válvula de aspiración compl.	
	20	8000 61101	2	Piastrina di fermo	Stop plate	Plaque d'arrêt	Stopplatte	Placa de retención	
	21	8A00 70381	2	Lamella	Plate	Lamelle	Plättchen	Laminilla	
	22	8000 61102	8	Vite	Screw	Vis	Schraube	Tornillo	
	23	60N1 15533	8	Rosetta elastica	Spring washer	Rondelle élastique	Federscheibe	Arandela elástica	

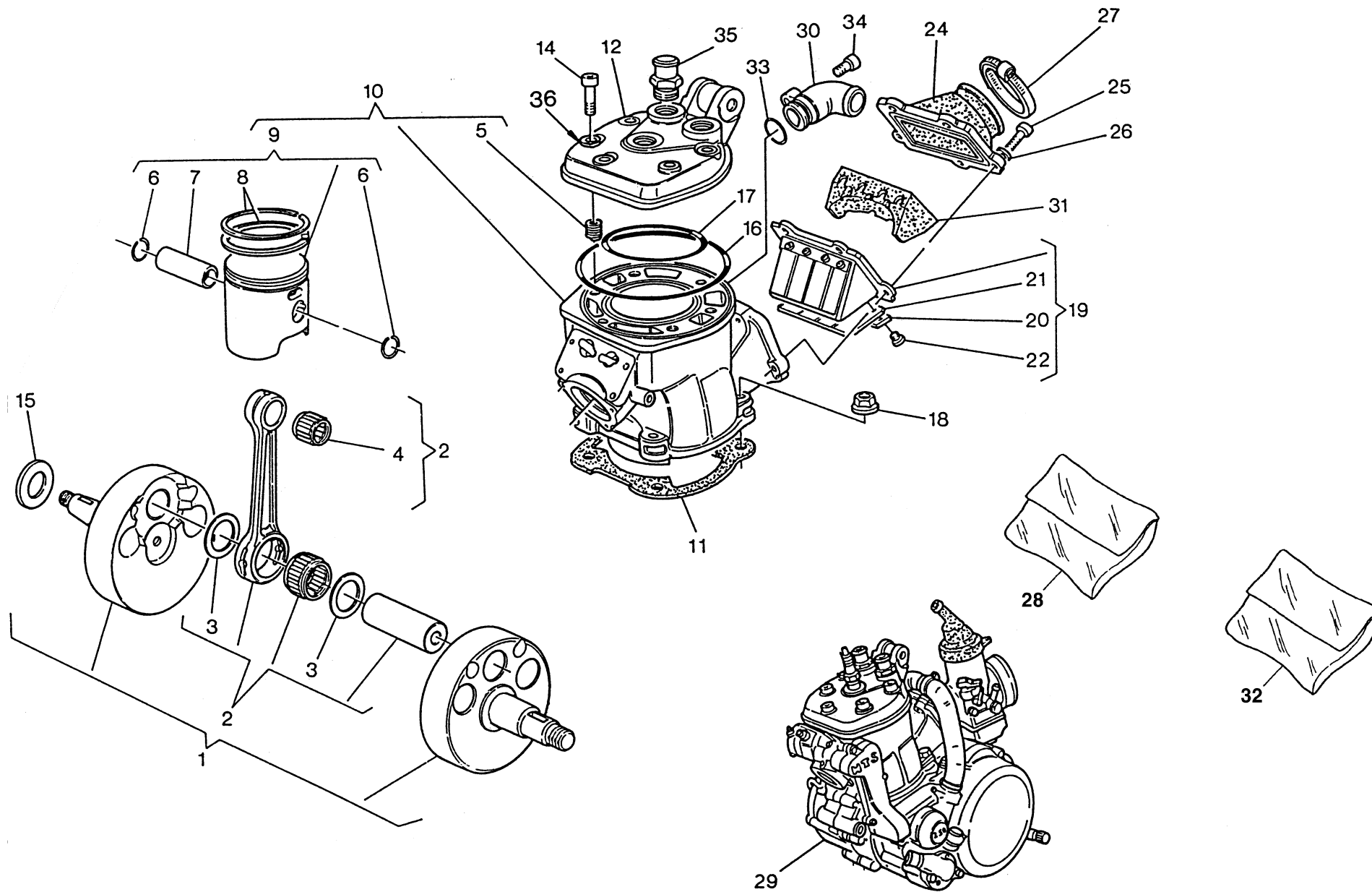



WR 360/2001

TAVOLA
DRAWING
TABLE
BILD
TABLA

2

TESTA, CILINDRO, PISTONE, MANOVELLISMO - CYLINDER HEAD, CYLINDER, PISTON, CRANKSHAFT
CULASSE, CYLINDRE, PISTON, VILEBREQUIN - ZYLINDERKOPF, ZYLINDER, KOLBEN, KURBELWELLE
CULATA, CILINDRO, PISTON, PALANCAS

Note Notes Notas	Pos. No. N. Index Pos.	N. Cod. Code No. Nr. Code Code Nr N. Cod.	Q.tà Q.ty Q.te M.ge C.ad	DENOMINAZIONE	NAME	DESIGNATION	BESHREIBUNG	DENOMINACION	Validità Validity Validité Gültig Validez
	24	8000 70667	1	Raccordo di aspir.	Union	Raccord	Anschluss	Empalme	
	25	60N1 02509	5	Vite	Screw	Vis	Schraube	Tornillo	
	26	62N1 15504	5	Rosetta piana	Washer	Rondelle	Scheibe	Arandela	
	27	8000 27521	1	Fascetta	Clamp	Collier	Schelle	Banda	
	28	8000 94855	1	Gruppo guarnizioni motore	Engine gasket set	Groupe garnitures moteur	Dichtunggruppe Motor	Grupo juntas	
	29	8000 88988	1	Motore completo	Crankshaft assy	Vilebrequin compl.	Kurbewelle kpl.	güeñal compl.	
	30	8000 63590	1	Raccordo	Union	Raccord	Anschluss	Empalme	
	31	8000 66473	1	Inserito valvola aspirazione	Inlet valve insert	Piece soupape admission	Einlass-Ventil Einsatz	Inserito válvula aspiración	
	32	8000 94856	1	Gruppo anelli di tenuta motore	Engine seal ring set	Groupe bague moteur	Dichtungringgruppe Motor	Grupo anillos	
	33	8000 18422	1	Anello di tenuta	Seal ring	Bague d'étanchéité	Dichtungring	Anillo de retención	
	34	60N1 07335	1	Vite	Screw	Vis	Schraube	Tornillo	
	35	8000 63885	2	Raccordo	Union	Raccord	Anschluss	Empalme	
	36	8000 39335	6	Rosetta piana in rame	Washer	Rondelle	Scheibe	Arandela	
H				Accoppiamento piede biella	Con.road small end coupl.	Couplage du pied de bielle	Verbin. pluelstangenkopfes	Acoplamiento pie de biela	

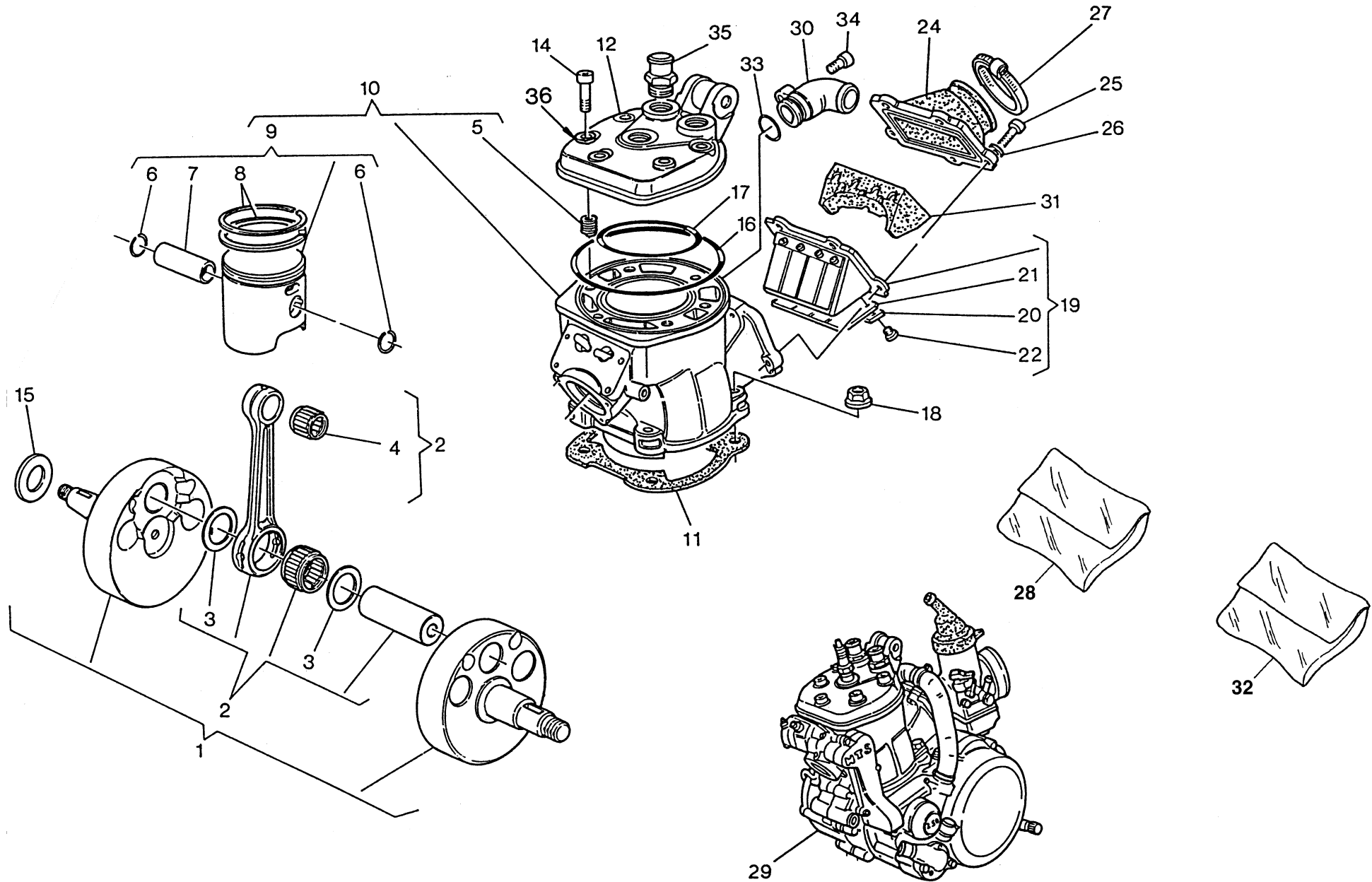



TESTA, CILINDRO, PISTONE, MANOVELLISMO - CYLINDER HEAD, CYLINDER, PISTON, CRANKSHAFT
CULASSE, CYLINDRE, PISTON, VILEBREQUIN - ZYLINDERKOPF, ZYLINDER, KOLBEN, KURBELWELLE
CULATA, CILINDRO, PISTON, PALANCAS

La sottoriportata tabella elenca i possibili accoppiamenti che consentono di ottenere il corretto gioco radiale di 0,002±0,010 mm

The table hereunder shows the possible coupling which allow to obtain a radial clearance of 0.002±0.010 mm

Le tableau ci-dessous indique tous les couplages possibles permettant d'obtenir le jeu radial exact de 0,002±0,010 mm

Die folgende Tabelle gibt die möglichen Verbindungen an für das genaue Radialspiel von 0,002±0,010 mm

La tabla que se da a continuación lista los acoplamientos posibles que permiten obtener el juego radial correcto de 0,002±0,010 mm

C: colore di selezione biella

C: rod selection colour

C: couleur de sélection bielle

C: Wahlfarbe der Pleuelstange

C: color de selección biela

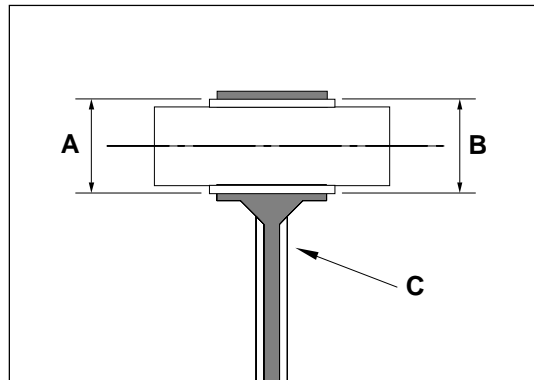

Colore di selezione foro «A» piede di biella (mm) Hole selection colour «A» connecting rod small end (mm) Couleur de sélection trou «A» pied de bielle (mm) Wahlfarbe der Bohrung «A» Pleuelstangenkopf (mm) Color de selección «A» pie de biela (mm)	Selezione gabbia a rullini «B» Cage selection «B» Sélection cage à rouleaux «B» Wahlnadelkäfig «B» Selección jaula de agujas «B»
Giallo - Yellow - Jaune - Gelb - Amarillo 21,994 " 21,996	- 3 ÷ - 5
Verde - Green - Vert - Grün - Verde 21,996 " 21,998	- 3 ÷ - 5
Bianco - White - Blanc - Weiss - Blanco 21,998 " 22,000	- 1 ÷ - 3 - 2 ÷ - 4
Nero - Black - Noir - Schwarz - Negro 22,000 " 22,002	0 ÷ - 2 - 1 ÷ - 3
Rosso - Red - Rouge - Rot - Rojo 22,002 " 22,004	0 ÷ - 2

Qualora, in sede di revisione del motore, si dovesse riscontrare un gioco radiale superiore al limite ammesso di 0,015 mm e non fosse più visibile il contrassegno del colore sullo stelo della biella, rilevare il diametro «A» del piede di biella e, in base a questo, montare la gabbietta appropriata.

When overhauling, should a radial clearance greater than the consented limit of 0.015 mm be noticed and the colour mark under the connecting rod small end is no more visible, collect the connecting rod small end «A» diameter and assemble the right cage according to it.

Si en révisonnant le moteur on trouve un jeu radial supérieur à la limite admise de 0,015 mm et le marque de la couleur n'est plus visible sur la tige de bielle, enregistrer le diamètre «A» du pied de bielle et assembler la cage exacte selon ce diamètre.

Falls bei Motorprüfung das Radialspiel über das zugelassene Mass von 0,015 mm sein sollte und das Farbkennzeichen an der Pleuelstange nicht mehr sichtbar ist, wird der «A»-Durchmesser des Pleuelstangenkopfes gemessen und aufgrund dessen der geeignete Käfig montiert.

En el caso que, cuando inspeccione el motor, encuentre un juego radial superior al límite admitido de 0,015 mm y no resultara más visible la señalización del color en el vástago de la biela, registre el diámetro «A» del piede biela y, sobre la base de este dato, monte la jaula adecuada.

NOTA: Nel richiedere la gabbia a rullini, specificare la selezione.

NOTE: When requesting the cage, specify the selection.

NOTA: En demandant la cage à rouleaux, spécifier la sélection.

BEMERKUNG: Bei Anfrage den genauen Wahlnadelkäfig angeben.

NOTA: cuando pida la jaula de agujas, especifique la selección.

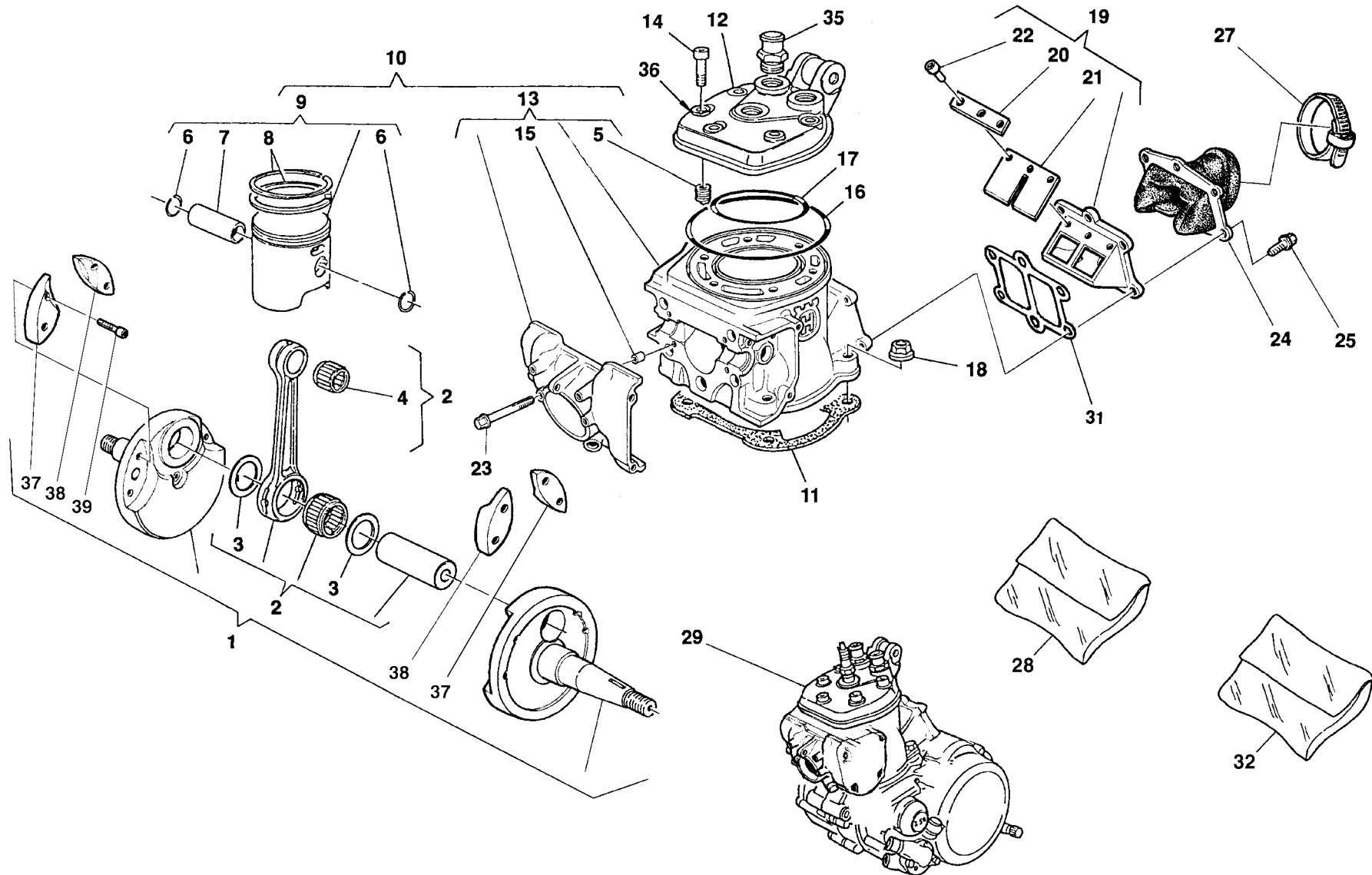

Note Notes Notas	Pos. No. N. Index Pos.	N. Cod. Code No. Nr. Code Code Nr N. Cod.	Q.tà Q.ty Q.te M.ge C.ad	DENOMINAZIONE	NAME	DESIGNATION	BESHREIBUNG	DENOMINACION	Validità Validity Validité Gültig Validez
	1	8000 89024	1	Albero motore completo	Crankshaft assy	Vilebrequin compl.	Kurbewelle kpl.	Cigüeñal compl.	
	2	8A00 50632	1	Biella completa	Connecting rod compl.	Bielle compl.	Pleuelstange kpl.	Biela motor completa	
	3	8000 50629	2	Rosetta di rasamento	Washer	Rondelle	Scheibe	Arandela	
H	4	8000 17826	1	Cuscinetto a rullini Ø18xØ22x22mm	Needle bearing Ø18xØ22x22mm	Roulement à aiguilles Ø18xØ22x22mm	Nadelkäfig Ø18xØ22x22mm	Cojinete de rodillos Ø18xØ22x22mm	
	5	8A00 30729	6	Helicoil	Inserted thread	Filetage appliq	Gewindeinsatz	Fileteado aplicado	
	6	8000 87765	2	Anello di fermo	Stop ring	Bague d'arrêt	Haltering	Anillo de retención	
	7	8000 86817	1	Spinotto	Gudgeon	Axe	Bolzen	Perno	
	8	8000 86819	2	Segmento	Circlip	Segment	Kolbenring	Segmento	
	9		1	Pistone completo	Compl. piston	Piston complet	Kolbe, kpl.	Pistón completo	
	9	8000 86806/1	1	A-B Ø66,335+66,345 mm	A-B Ø66,335+66,345 mm	A-B Ø66,335+66,345 mm	A-B Ø66,335+66,345 mm	A-B Ø66,335+66,345 mm	
	9	8000 86806/2	1	C-D Ø66,345+66,355 mm	C-D Ø66,345+66,355 mm	C-D Ø66,345+66,355 mm	C-D Ø66,345+66,355 mm	C-D Ø66,345+66,355 mm	
	9	8000 86806/3	1	E-F Ø66,355+66,365 mm	E-F Ø66,355+66,365 mm	E-F Ø66,355+66,365 mm	E-F Ø66,355+66,365 mm	E-F Ø66,355+66,365 mm	
	10	8000 97233	1	Cilindro completo	Cylinder assy	Cylindre compl.	Zylinder kpl.	Cilindro compl.	
	11	8000 86902	1	Guarnizione Sp. 0,3 mm	Gasket Th. 0,3 mm	Garniture Sp. 0,3 mm	Dichtung Sp. 0,3 mm	Junta Sp. 0,3 mm	
	11	8A00 86902	1	Guarnizione Sp. 0,4 mm	Gasket Th. 0,4 mm	Garniture Sp. 0,4 mm	Dichtung Sp. 0,4 mm	Junta Sp. 0,4 mm	
	11	8B00 86902	1	Guarnizione Sp. 0,5 mm	Gasket Th. 0,5 mm	Garniture Sp. 0,5 mm	Dichtung Sp. 0,5 mm	Junta Sp. 0,5 mm	
	11	8C00 86902	1	Guarnizione Sp. 0,8 mm	Gasket Th. 0,8 mm	Garniture Sp. 0,8 mm	Dichtung Sp. 0,8 mm	Junta Sp. 0,8 mm	
	12	8000 86823	1	Testa cilindro	Cylinder head	Culasse	Zylinderkopf	Cabeza cilindro	
	13	8000 97234	1	Ass. cilindro	Cylinder assy	Groupe culasse	Zylindergruppe	Grupo cilindro	
	14	8K00 69056	6	Vite M8x35mm	Screw M8x35mm	Vis M8x35mm	Schraube M8x35mm	Tornillo M8x35mm	
	15	1617 95501	2	Bussola	Bush	Douille	Buchse	Manguito	
	16	8A00 63593	1	Anello OR	O-Ring	Bague OR	O-Ring	Anillo OR	
	17	8A00 44117	1	Anello OR	O-Ring	Bague OR	O-Ring	Anillo OR	
	18	8000 38624	4	Dado	Nut	Ecrou	Mutter	Tuerca	
	19	8000 86825	1	Valvola aspirazione compl.	Inlet valve assy	Soupape d'aspiration compl.	Einlassventil kpl.	Válvula de aspiración compl.	
	20	8000 86827	2	Piastrina di fermo	Stop plate	Plaque d'arrêt	Stopplatte	Placa de retención	
	21	8000 86828	2	Lamella	Plate	Lamelle	Plättchen	Laminilla	
	22	8000 61102	6	Vite	Screw	Vis	Schraube	Tornillo	
	23	8E00 67545	4	Vite	Screw	Vis	Schraube	Tornillo	
	24	8000 86851	1	Raccordo di aspir.	Union	Raccord	Anschluss	Empalme	
	25	8000 62729	6	Vite	Screw	Vis	Schraube	Tornillo	

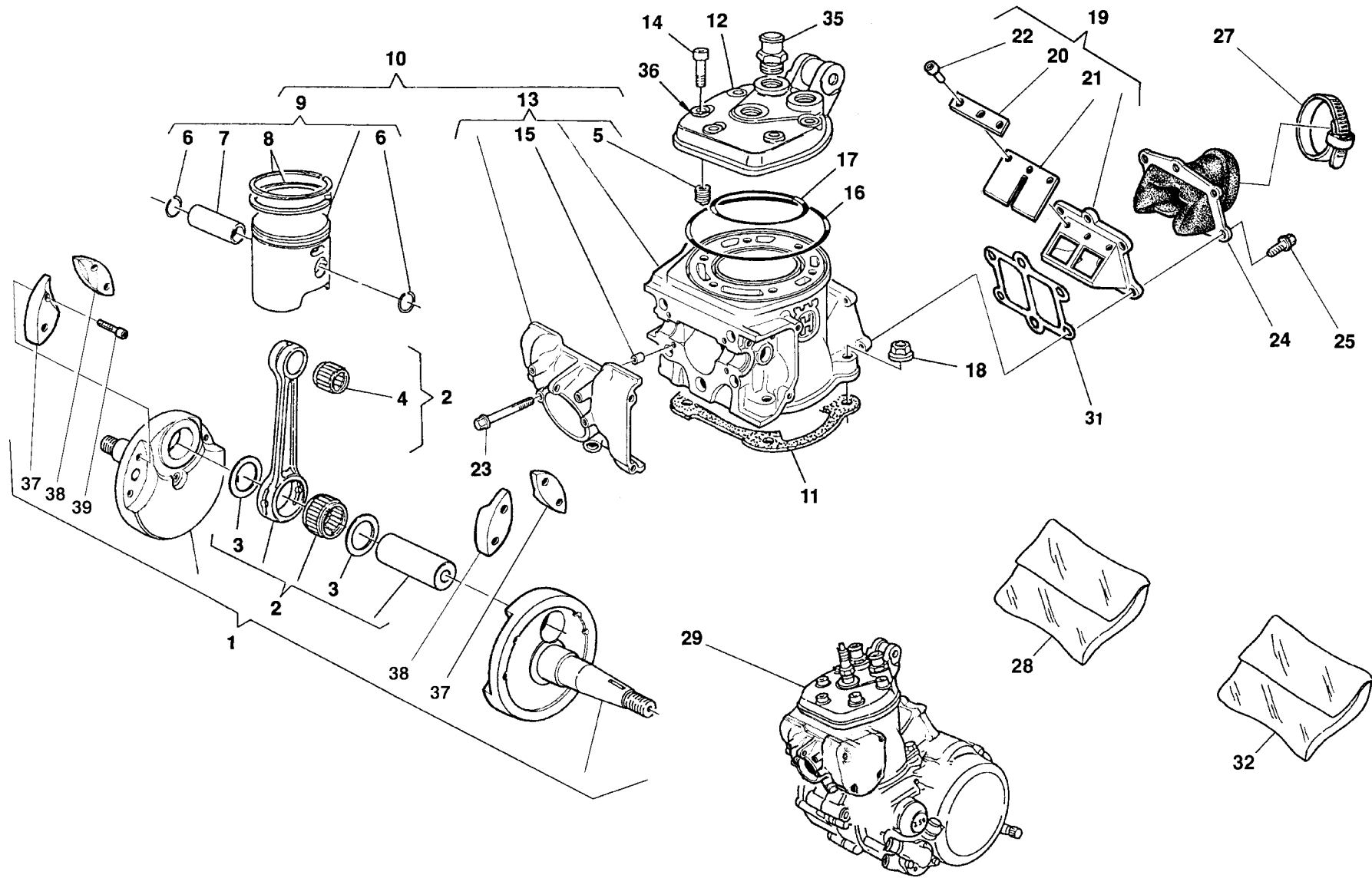



WR - CR 250/2001

TAVOLA
DRAWING
TABLE
BILD
TABLA

2A

TESTA, CILINDRO, PISTONE, MANOVELLISMO - CYLINDER HEAD, CYLINDER, PISTON, CRANKSHAFT
CULASSE, CYLINDRE, PISTON, VILEBREQUIN - ZYLINDERKOPF, ZYLINDER, KOLBEN, KURBELWELLE
CULATA, CILINDRO, PISTON, PALANCAS

Note Notes Notas	Pos. No. N. Index Pos.	N. Cod. Code No. Nr. Code Code Nr N. Cod.	Q.tà Q.ty Q.te M.ge C.ad	DENOMINAZIONE	NAME	DESIGNATION	BESHREIBUNG	DENOMINACION	Validità Validity Validité Gültig Validez
	27	8000 27521	1	Fascetta	Clamp	Collier	Schelle	Banda	
R	28	8000 94853	1	Gruppo guarnizioni motore	Engine gasket set	Groupe garnitures moteur	Dichtunggruppe Motor	Grupo juntas	
W	29	8000 97143	1	Motore completo	Crankshaft assy	Vilebrequin compl.	Kurbewelle kpl.	güeñal compl.	
C	29	8000 97145	1	Motore completo	Crankshaft assy	Vilebrequin compl.	Kurbewelle kpl.	güeñal compl.	
	31	8000 89954	1	Guarnizione	Gasket	Garniture	Dichtung	Junta	
	32	8000 94854	1	Gruppo anelli di tenuta motore	Engine seal ring set	Groupe bague moteur	Dichtungringgruppe Motor	Grupo anillos	
	35	8000 63885	2	Raccordo	Union	Raccord	Anschluss	Empalme	
	36	8000 39335	6	Rosetta piana in rame	Washer	Rondelle	Scheibe	Arandela	
	37	8000 86857	2	Inserto sinistro	L.H. insert	Insert gauche	Link Platte	Inserto izquierdo	
	38	8000 86858	2	Inserto destro	R.H. insert	Insert droite	Recht Platte	Inserto .0derecho	
	39	60N1 02506	4	Vite	crew	Vis	Schraube	Tornillo	
H				Accoppiamento piede biella	Con. road small end coupl.	Couplage du pied de bielle	Verbin. pluelstangenkopfes	Acoplamiento pie de biela	

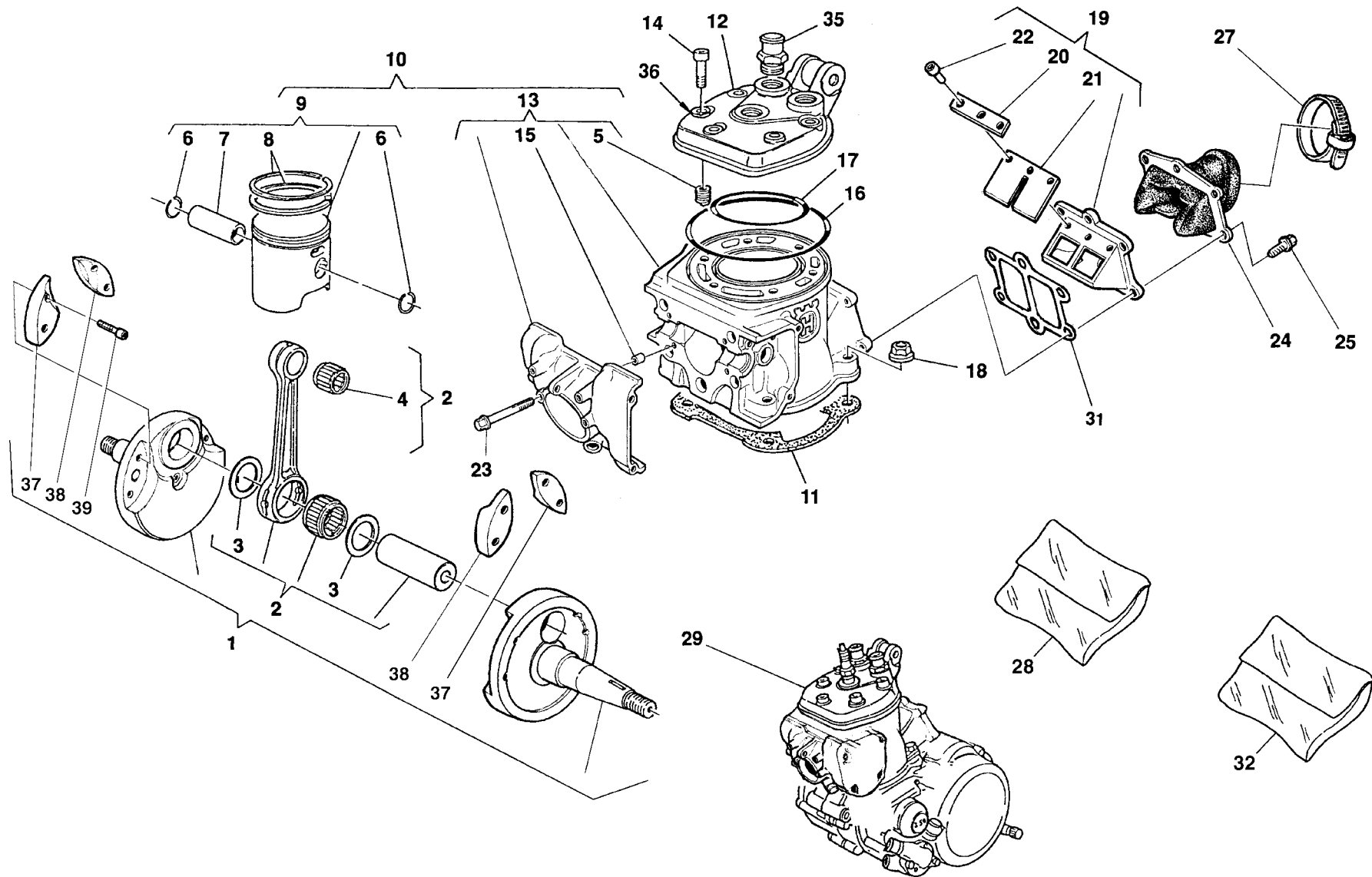

La sottoriportata tabella elenca i possibili accoppiamenti che consentono di ottenere il corretto gioco radiale di 0,002±0,010 mm

The table hereunder shows the possible coupling which allow to obtain a radial clearance of 0.002±0.010 mm

Le tableau ci-dessous indique tous les couplages possibles permettant d'obtenir le jeu radial exact de 0,002±0,010 mm

Die folgende Tabelle gibt die möglichen Verbindungen an für das genaue Radialspiel von 0,002±0,010 mm

La tabla que se da a continuación lista los acoplamientos posibles que permiten obtener el juego radial correcto de 0,002±0,010 mm

C: colore di selezione biella

C: rod selection colour

C: couleur de sélection bielle

C: Wahlfarbe der Pleuelstange

C: color de selección biela

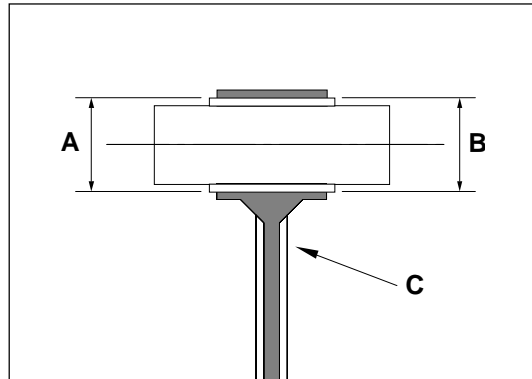

Colore di selezione foro «A» piede di biella (mm) Hole selection colour «A» connecting rod small end (mm) Couleur de sélection trou «A» pied de bielle (mm) Wahlfarbe der Bohrung «A» Pleuelstangenkopf (mm) Color de selección «A» pie de biela (mm)	Selezione gabbia a rullini «B» Cage selection «B» Sélection cage à rouleaux «B» Wahlnadelkäfig «B» Selección jaula de agujas «B»
Giallo - Yellow - Jaune - Gelb - Amarillo 21,994 " 21,996	- 3 ÷ - 5
Verde - Green - Vert - Grün - Verde 21,996 " 21,998	- 3 ÷ - 5
Bianco - White - Blanc - Weiss - Blanco 21,998 " 22,000	- 1 ÷ - 3 - 2 ÷ - 4
Nero - Black - Noir - Schwarz - Negro 22,000 " 22,002	0 ÷ - 2 - 1 ÷ - 3
Rosso - Red - Rouge - Rot - Rojo 22,002 " 22,004	0 ÷ - 2

Qualora, in sede di revisione del motore, si dovesse riscontrare un gioco radiale superiore al limite ammesso di 0,015 mm e non fosse più visibile il contrassegno del colore sullo stelo della biella, rilevare il diametro «A» del piede di biella e, in base a questo, montare la gabbietta appropriata.

When overhauling, should a radial clearance greater than the consented limit of 0.015 mm be noticed and the colour mark under the connecting rod small end is no more visible, collect the connecting rod small end «A» diameter and assemble the right cage according to it.

Si en révisonnant le moteur on trouve un jeu radial supérieur à la limite admise de 0,015 mm et le marque de la couleur n'est plus visible sur la tige de bielle, enregistrer le diamètre «A» du pied de bielle et assembler la cage exacte selon ce diamètre.

Falls bei Motorprüfung das Radialspiel über das zugelassene Mass von 0,015 mm sein sollte und das Farbkennzeichen an der Pleuelstange nicht mehr sichtbar ist, wird der «A»-Durchmesser des Pleuelstangenkopfes gemessen und aufgrund dessen der geeignete Käfig montiert..

En el caso que, cuando inspeccione el motor, encuentre un juego radial superior al límite admitido de 0,015 mm y no resultara más visible la señalización del color en el vástago de la biela, registre el diámetro «A» del piede biela y, sobre la base de este dato, monte la jaula adecuada.

NOTA: Nel richiedere la gabbia a rullini, specificare la selezione.

NOTE: When requesting the cage, specify the selection.

NOTA: En demandant la cage à rouleaux, spécifier la sélection.

BEMERKUNG: Bei Anfrage den genauen Wahlnadelkäfig angeben.

NOTA: cuando pida la jaula de agujas, especifique la selección.

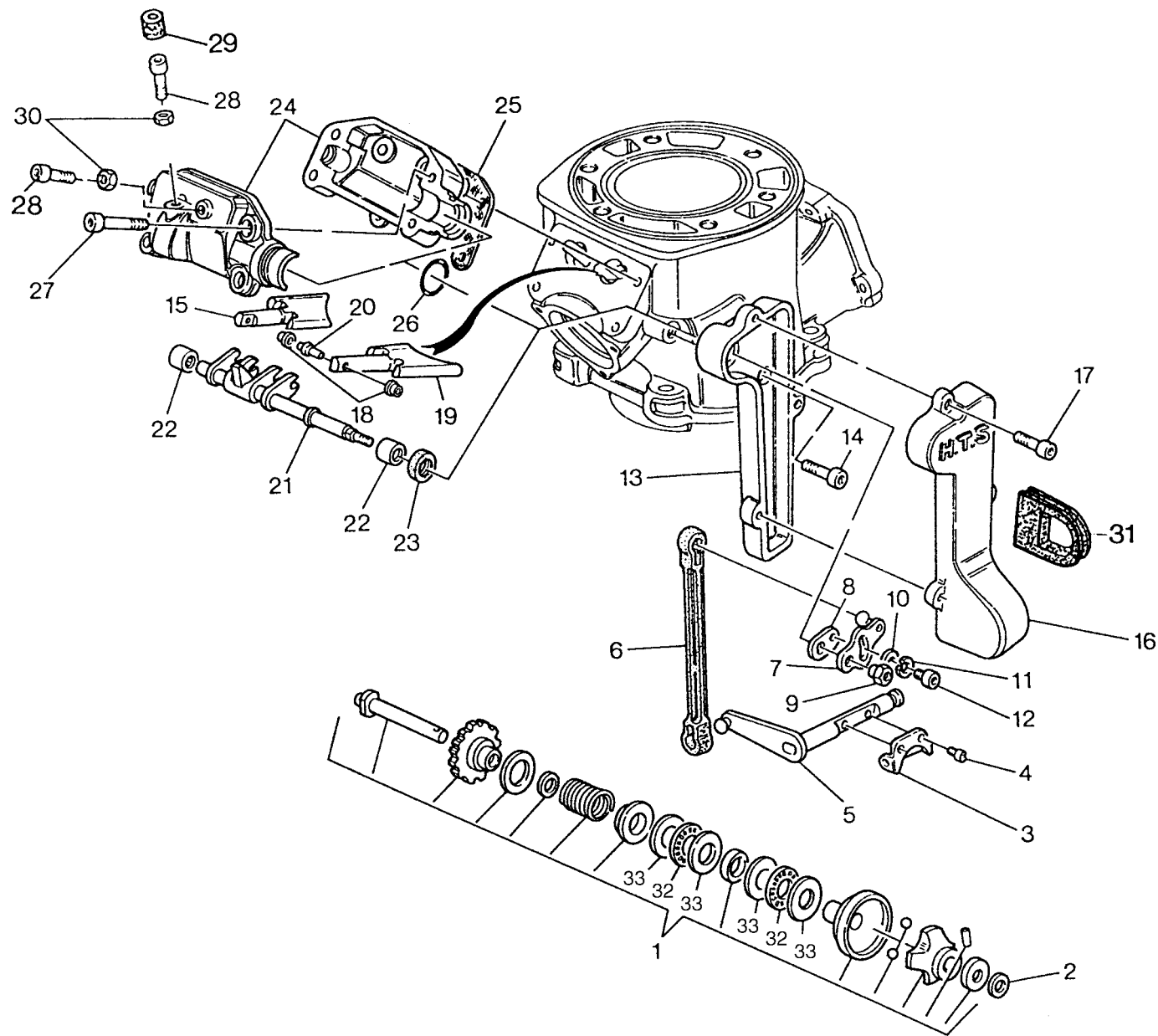



WR 360/2001

TAVOLA
DRAWING
TABLE
BILD
TABLA

3

H.T.S. - H.T.S.
H.T.S. - H.T.S.
H.T.S.

Note Notes Notas	Pos. No. Index	N. Cod. Code No. Nr. Code Code Nr N. Cod.	Q.tà Q.ty Q.te M.ge C.ad	DENOMINAZIONE	NAME	DESIGNATION	BESHREIBUNG	DENOMINACION	Validità Validity Validité Gültig Validez
	1	8000 74870	1	Regol. com. valvola	Valve drive regulator	Registre com. soupape	Regler für Abzapventil.	Regul. mando válvula	
	2	8000 34292	1	Rosetta di ras. (0,3 mm)	Washer (0,3 mm)	Rondelle (0,3 mm)	Scheibe (0,3 mm)	Arandela (0,3 mm)	
	2	8F00 34292	1	Rosetta di ras. (0,9 mm)	Washer (0,9 mm)	Rondelle (0,9 mm)	Scheibe (0,9 mm)	Arandela (0,9 mm)	
	2	8G00 34292	1	Rosetta di ras. (1,0 mm)	Washer (1,0 mm)	Rondelle (1,0 mm)	Scheibe (1,0 mm)	Arandela (1,0 mm)	
	3	8000 35620	1	Forcella comando valvola	Control fork	Fourche commande	Gabel	Horquilla	
	4	60N1 02870	2	Vite	Screw	Vis	Schraube	Tornillo	
	5	8000 57019	1	Alberino rinvio	Counter shaft	Arbre de renvoi	Vorgelegewelle	Eje de reencio	
	6	8B00 57027	1	Astina	Control rod	Coulisseau	Steuerstange	Varilla	
	7	8000 57022	1	Leva comando	Lever	Levier	Hebel	Palanca	
	8	8000 57024	1	Leva	Lever	Levier	Hebel	Palanca	
	9	8000 52545	1	Dado	Nut	Ecrou	Mutter	Tuerca	
	10	62N1 15503	1	Rosetta piana	Washer	Rondelle	Scheibe	Arandela	
	11	62N1 15535	1	Rosetta elastica	Spring washer	Rondelle élastique	Federscheibe	Arandela elástica	
	12	60N1 02482	1	Vite	Screw	Vis	Schraube	Tornillo	
	13	8000 73370	1	Base coperchio	Cover basis	Socle pour couvercle	Dekel-basis	Base tapa	
	14	60N1 02483	2	Vite	Screw	Vis	Schraube	Tornillo	
	15	8A00 73440	1	Valvola di scarico DX	Exhaust valve	Soupape d'échappement	Auslass-Ventil	Válvula de escape	
	16	8000 73371	1	Coperchio	Cover	Couvercle	Deckel	Tapa	
	17	60N1 02483	3	Vite	Screw	Vis	Schraube	Tornillo	
	18	8000 58048	1	Rotella	Wheel	Galet	Rädchen	Ruedecilla	
	19	8A00 73441	1	Valvola di scarico SX	Exhaust valve	Soupape d'échappement	Auslass-Ventil	Válvula de escape	
	20	8000 58046	1	Perno	Pin	Pivot	Bolzen	Perno	
	21	8000 68816	1	Perno	Pin	Pivot	Bolzen	Perno	
	22	8000 31748	2	Boccola a rullini (ø8xø12x10 mm)	Rollenbush (ø8xø12x10 mm)	Douille rouleaux (ø8xø12x10 mm)	Rollerbuchse (ø8xø12x10 mm)	Casquillo (ø8xø12x10 mm)	
	23	8000 64296	1	Anello di tenuta (ø8xø16x5 mm)	Seal ring (ø8xø16x5 mm)	Bague d'étanchéité (ø8xø16x5 mm)	Dichtungsring (ø8xø16x5 mm)	Anillo de retención (ø8xø16x5 mm)	
	24	8000 70642	1	Supporto completo	Support	Support	Halterung	Soporte	
	25	8000 73443	1	Guarnizione	Gasket	Garniture	Dichtung	Junta	
	26	8000 36380	1	Anello OR	O-Ring	Bague OR	O-Ring	Anillo OR	
	27	60N2 02489	4	Vite	Screw	Vis	Schraube	Tornillo	
	28	60N1 02487	2	Vite	Screw	Vis	Schraube	Tornillo	

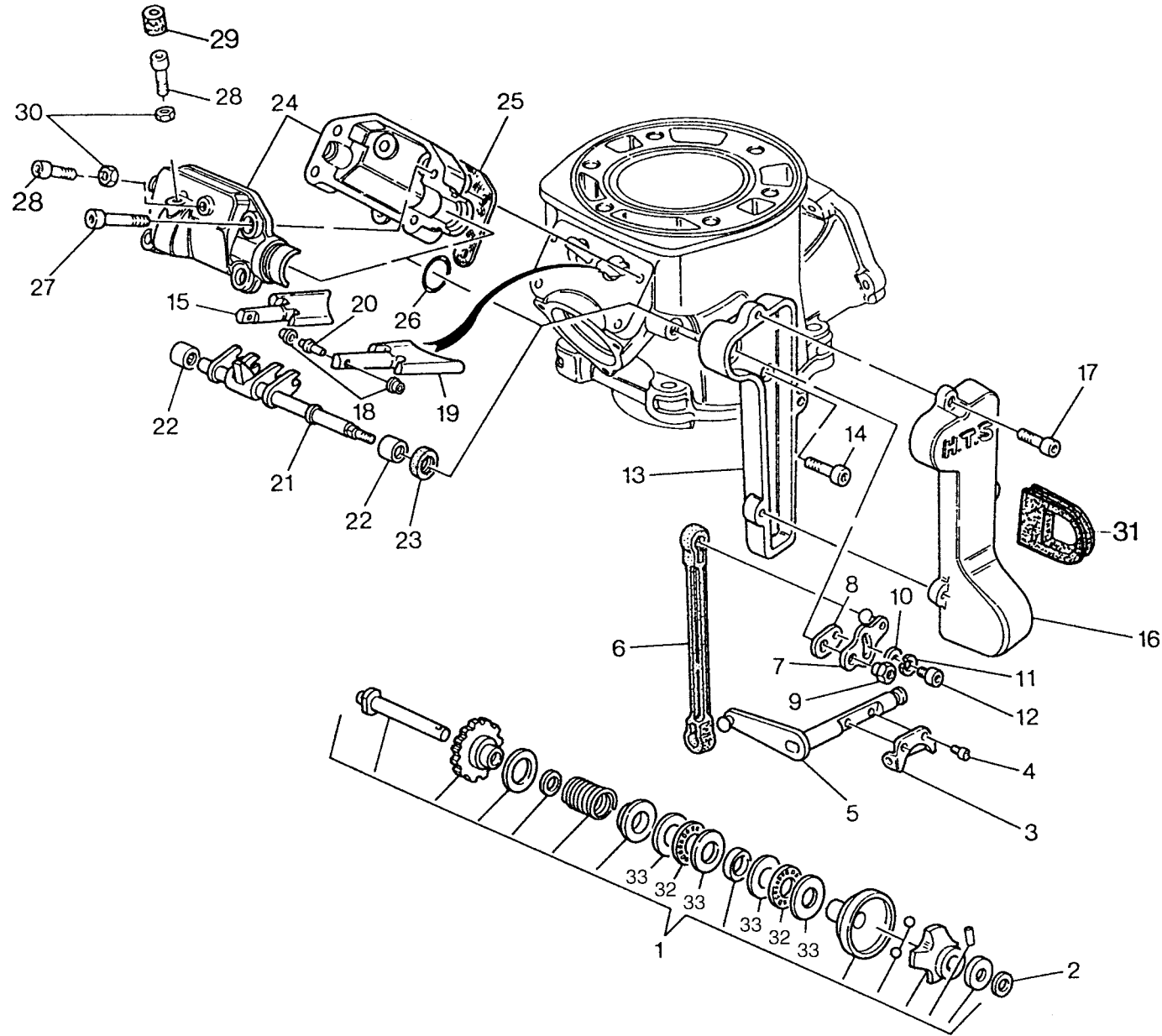



WR 360/2001

TAVOLA
DRAWING
TABLE
BILD
TABLA

3

H.T.S. - H.T.S.
H.T.S. - H.T.S.
H.T.S.

Note Notes Marka Notas	Pos. No. N. Index Pos.	N. Cod. Code No. Nr. Code Code Nr N. Cod.	Q.tà Q.ty Q.te M.ge C.ad	DENOMINAZIONE	NAME	DESIGNATION	BESHREIBUNG	DENOMINACION	Validità Validity Validité Gültig Validez
	29	8000 74261	2	Gommino	Rubber pad	Piece caoutchouc	Gummistuck	Goma	
	30	61N1 15032	2	Dado	Nut	Ecrou	Mutter	Tuerca	
	31	8000 50559	1	Guarnizione	Gasket	Garniture	Dichtung	Junta	
	32	8000 35780	2	Cuscinetto assiale	Bearing	Roulement	Lager	Cojinete	
	33	8000 35781	4	Ralla	Washer	Rondelle	Scheibe	Arandela	

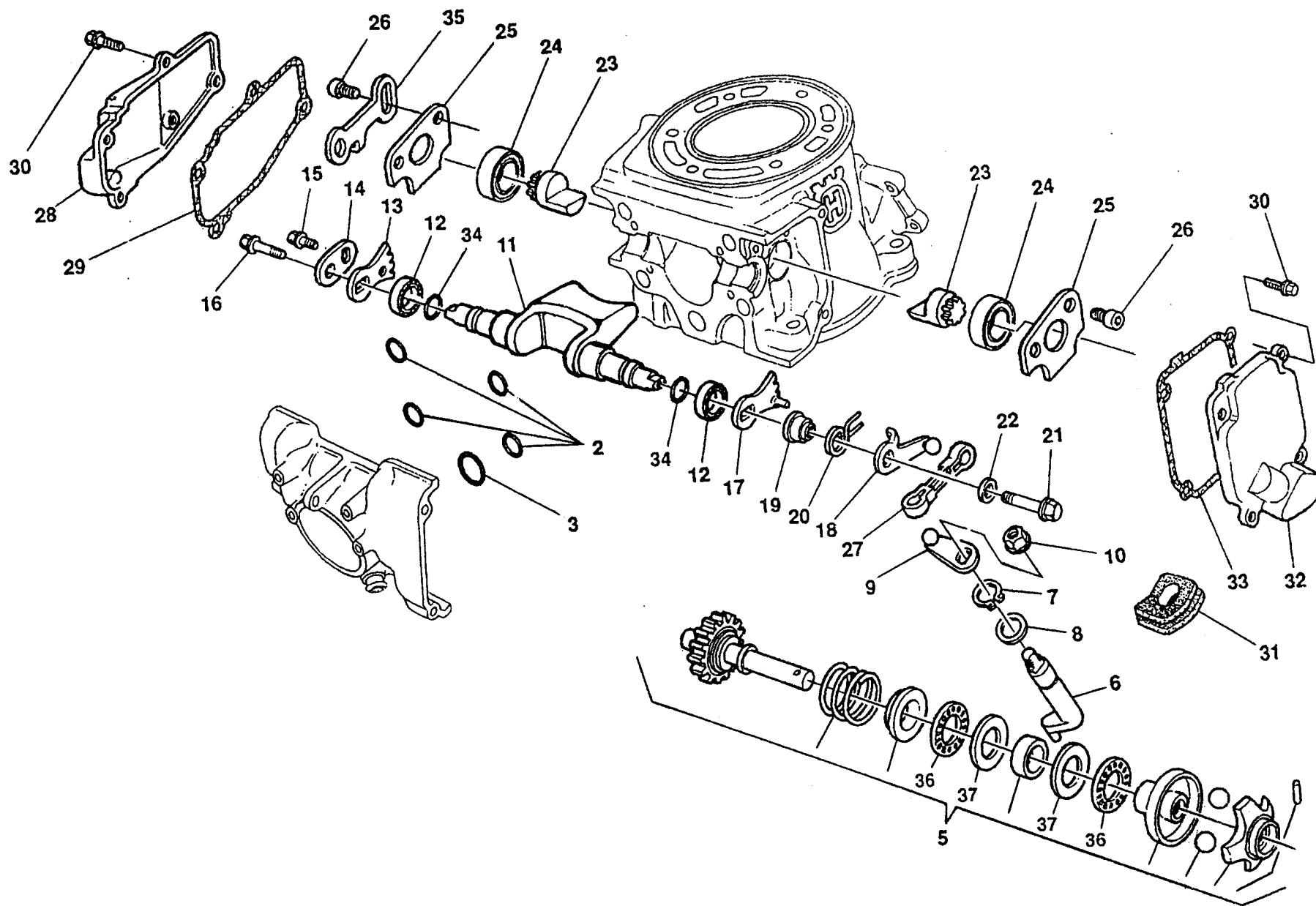

Note Notes Marka Notas	Pos. No. N. Index Pos.	N. Cod. Code No. Nr. Code Code Nr N. Cod.	Q.tà Q.ty Q.te M.ge C.ad	DENOMINAZIONE	NAME	DESIGNATION	BESHREIBUNG	DENOMINACION	Validità Validity Validité Gültig Validez
	2	8A00 23109	4	Anello OR	O-Ring	Bague OR	O-Ring	Anillo OR	
	3	8000 36380	1	Anello OR	O-Ring	Bague OR	O-Ring	Anillo OR	
	5	8000 86840	1	Regolatore comando valvola di scarico	Valve drive regulator	Registre com. soupape	Regler für Abzapventil.	Regul. mando válvula	
	6	8000 86843	1	Alberino rinvio	Countershaft	Arbre de renvoi	Vorgelegewelle	Eje de reencío	
	7	8000 21375	1	Anello SEEGER	SEEGER ring	Anneau SEEGER	SEEGER Ring	Anillo SEEGER	
	8	8000 56377	1	Rosetta	Washer	Rondelle	Scheibe	Arandela	
	9	8000 54899	1	Leva	Lever	Levier	Hebel	Palanca	
	10	8000 42278	1	Dado	Nut	Ecrou	Mutter	Tuerca	
	11	8000 97252	1	Valvola di scarico	Exhaust valve	Soupape d'échappement	Auslass-Ventil	Válvula de escape	
	12	8000 89957	2	Bussola	Bushing	Douille	Buchse	Manguito	
	13	8A00 86845	1	Ingranaggio Dx	R.H. gear	Engrenage D.	Zahnrad Rechte	Engranaje der.	
	14	8000 86847	1	Piastrina	Plate	Plaquette	Platte	Placa	
	15	8F00 67997	1	Vite	Screw	Vis	Schraube	Tornillo	
	16	8000 62728	1	Vite	Screw	Vis	Schraube	Tornillo	
	17	8000 86846	1	Ingranaggio Sx	L.H. gear	Engrenage G.	Zahnrad Linke	Engranaje iz.	
	18	8000 82943	1	Leva	Lever	Levier	Hebel	Palanca	
	19	8000 86849	1	Mozzo	Hub	Moyeau	Radnabe	Cubo	
	20	8000 86850	1	Molla	Spring	Ressort	Feder	Resorte	
	21	8000 62730	1	Vite	Screw	Vis	Schraube	Tornillo	
	22	8000 02709	1	Rosetta	Washer	Rondelle	Scheibe	Arandela	
	23	8000 86844	2	Valvola BOOSTER	BOOSTER valve	Soupape BOOSTER	Auslass BOOSTER	Válvula BOOSTER	
	24	8000 92225	2	Bussola	Bushing	Douille	Buchse	Manguito	
	25	8000 86848	2	Piastrina	Plate	Plaquette	Platte	Placa	
	26	8000 67997	4	Vite	Screw	Vis	Schraube	Tornillo	
	27	8000 69750	1	Astina	Control rod	Coulisseau	Steuerstange	Varilla	
	28	8000 86864	1	Coperchio Dx	R.H. cover	Couvercle D.	Deckel Rechte	Tapa der.	
	29	8000 86865	1	Guarnizione	Gasket	Garniture	Dichtung	Junta	
	30	8000 62727	9	Vite	Screw	Vis	Schraube	Tornillo	
	31	8000 86866	1	Passacavo	Fairlead	Passecâble	Kabelführung	Prensacable	
	32	8000 86867	1	Coperchio Sx	L.H. cover	Couvercle G.	Deckel Linke	Tapa iz.	
	33	8000 86868	1	Guarnizione	Gasket	Garniture	Dichtung	Junta	

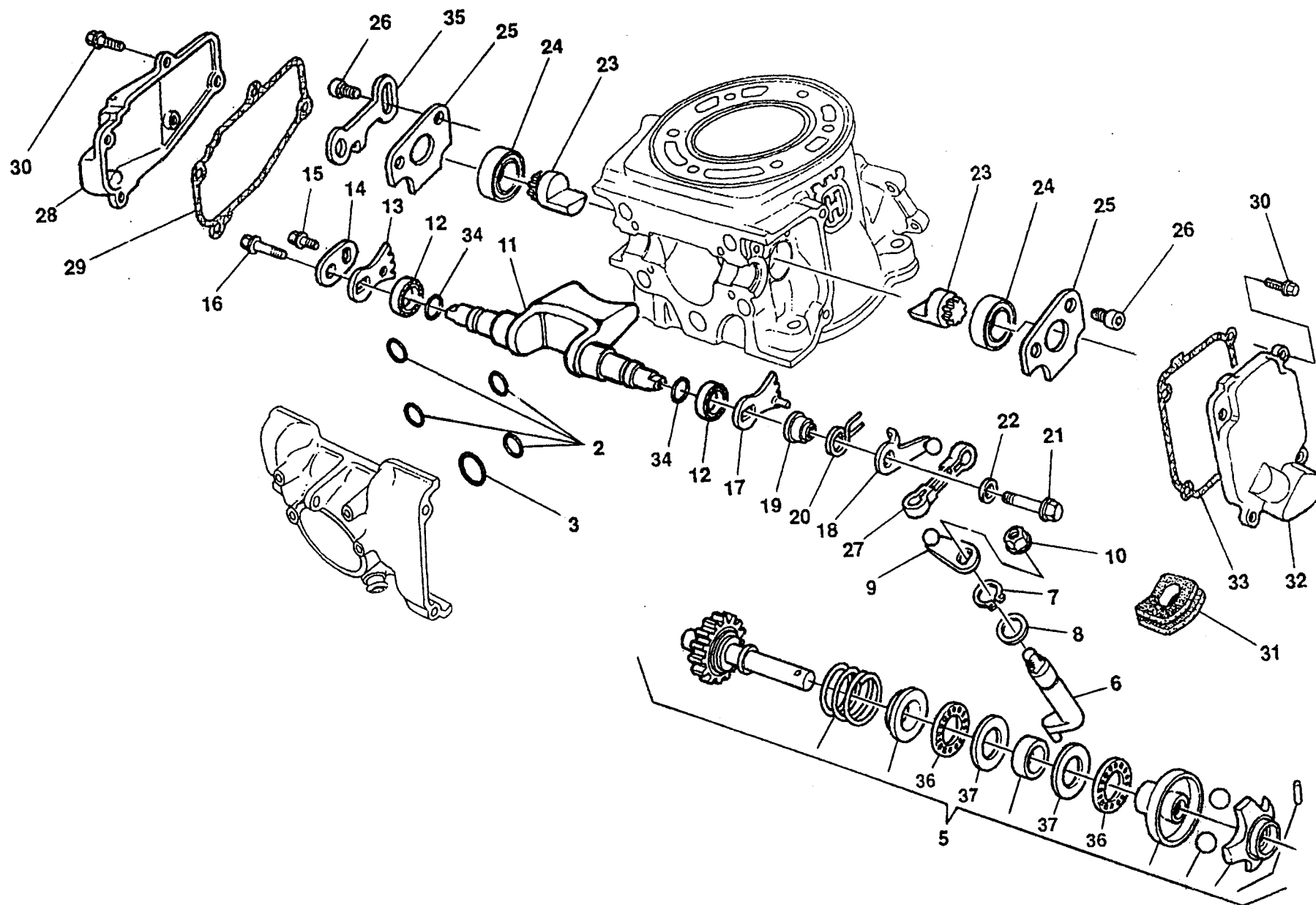

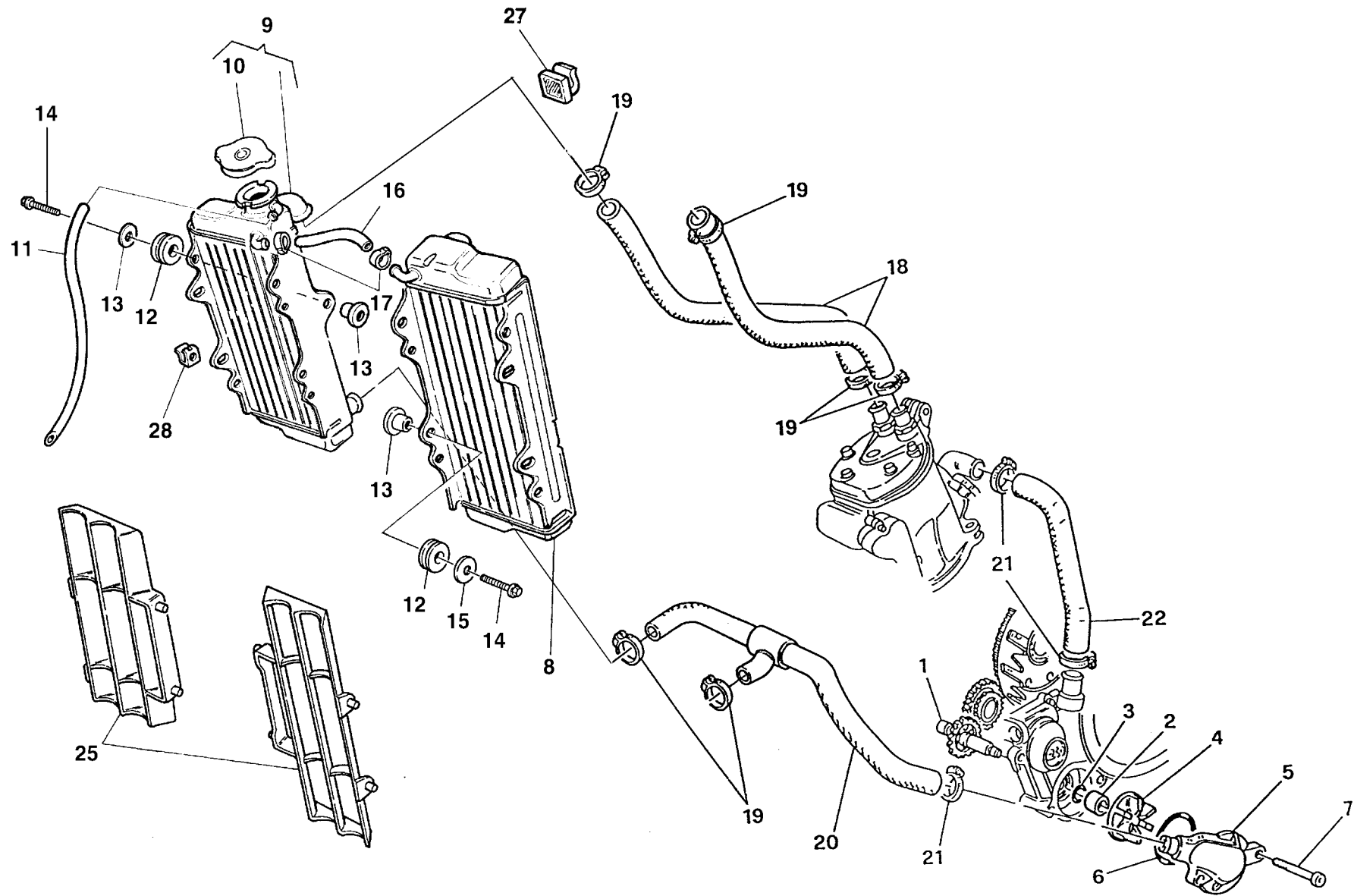



WR 360/2001

TAVOLA
DRAWING
TABLE
BILD
TABLA

4

RAFFREDDAMENTO - COOLING
REFROIDISSEMENT - WASSERKÜHLUNG
ENFRIAMIENTO

Note Notes Notas	Pos. No. Index Pos.	N. Cod. Code No. Nr. Code Code Nr N. Cod.	Q.tà Q.ty Q.te M.ge C.ad	DENOMINAZIONE	NAME	DESIGNATION	BESHREIBUNG	DENOMINACION	Validità Validity Validité Gültig Validez
	1	8000 59843	1	Alb. rinvio com. pompa	Counter shaft	Arbre de renvoi	Vorgelegewelle	Eje de reencio	
	2	8000 59844	1	Distanziale	Spacer	Entretoise	Distanzstück	Separador	
	3	8000 34083	1	Anello OR	O-Ring	Bague OR	O-Ring	Anillo OR	
	4	8000 59845	1	Girante	Rotor	Couronne	Laufrad	Rotor	
	5	8000 59856	1	Coperchio pompa	Pump cover	Couvercle pompe	Pumpendeckel	Tapa bomba	
	6	8000 19965	1	Anello OR	O-Ring	Bague OR	O-Ring	Anillo OR	
	7	60N1 02515	2	Vite	Screw	Vis	Schraube	Tornillo	
	8	8000 92215	1	Radiatore sinistro	Left radiator	Radiateur gauche	Linker Kühler	Radiador izquierdo	
	9	8000 92216	1	Radiatore destro compl.	Right radiator compl.	Radiateur droit compl.	Rechter Kühler kpl.	Radiador derecho compl.	
	10	8000 79077	1	Tappo radiatore	Plug	Bouchon	Verschluss	Tapón	
	11	8B00 43715	1	Tubo sfiato	Pipe	Tuyau	Rohr	Tubo	
	12	8000 59803	6	Gommino	Rubber pad	Pièce caoutchouc	Gummstück	Junta de goma	
	13	8D00 59802	6	Bussola	Bushing	Douille	Buchse	Manguito	
	14	8000 62729	6	Vite	Screw	Vis	Schraube	Tornillo	
	15	8000 59801	6	Rosetta	Washer	Rondelle	Scheibe	Arandela	
	16	8C00 43716	1	Condotto	Pipe	Tuyau	Rohr	Tubo	
	17	8000 56462	2	Fascetta	Clamp	Collier	Schelle	Banda	
	18	8000 94117	2	Condotto	Pipe	Tuyau	Rohr	Tubo	
	19	8000 46881	6	Fascetta	Clamp	Collier	Schelle	Banda	
	20	8A00 73340	2	Condotto	Pipe	Tuyau	Rohr	Tubo	
	21	8000 35751	3	Fascetta	Clamp	Collier	Schelle	Banda	
	22	8000 63630	1	Condotto	Pipe	Tuyau	Rohr	Tubo	
	25	80A0 67248	2	Griglia	Grid	Grille	Rost	Parrilla	
U	27	8000 57205	1	Gancio ritegno cavi	Hook	Crochet	Haken	Gancho	
	28	8000 60873	4	Dado a graffetta	Nut	Ecrou	Mutter	Tuerca	

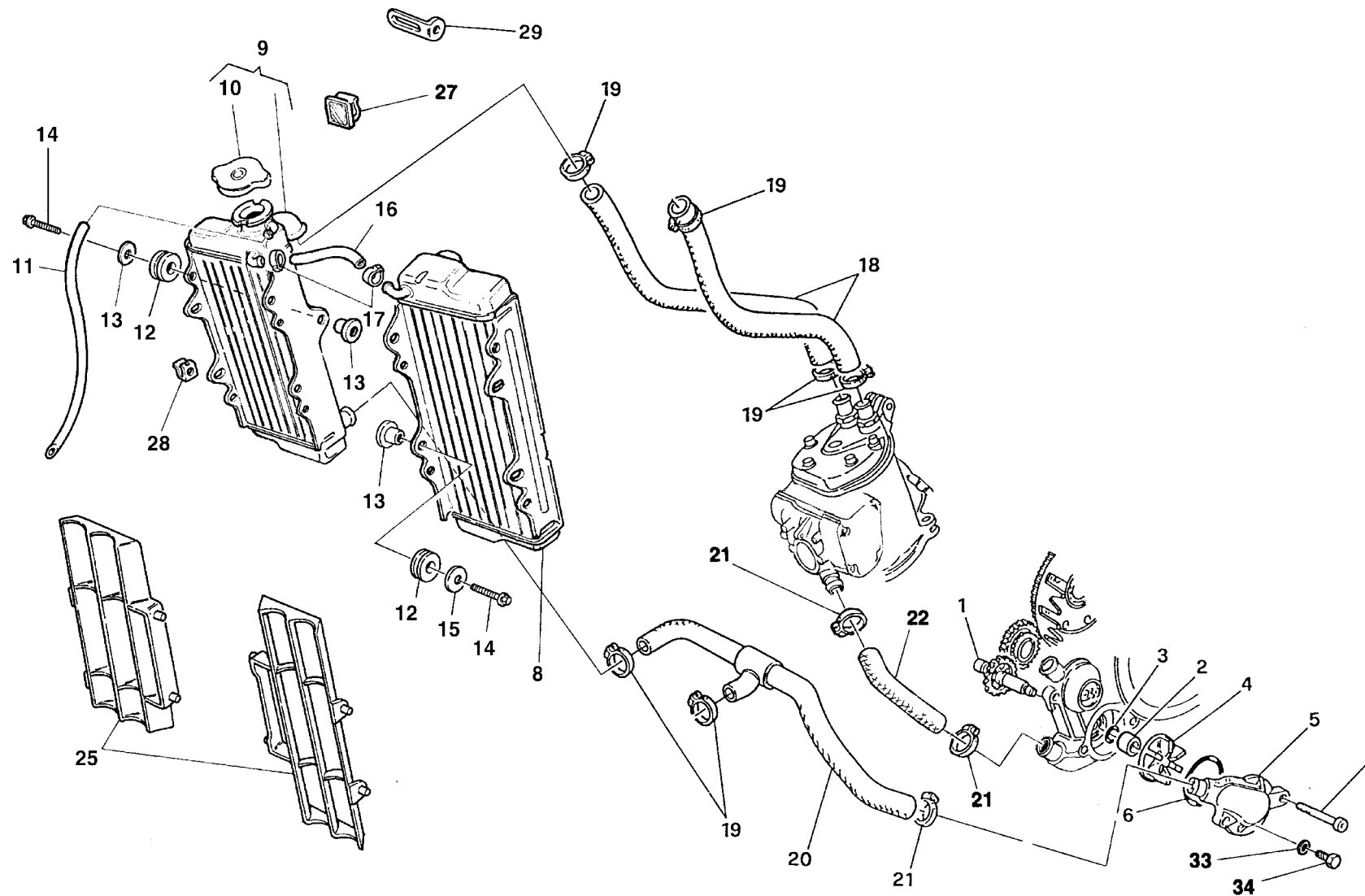

Note Notes Notas	Pos. No. Index	N. Cod. Code No. Nr. Code Code Nr N. Cod.	Q.tà Q.ty Q.te M.ge C.ad	DENOMINAZIONE	NAME	DESIGNATION	BESHREIBUNG	DENOMINACION	Validità Validity Validité Gültig Validez
	1	8000 59843	1	Alb. rinvio com. pompa	Counter shaft	Arbre de renvoi	Vorgelegewelle	Eje de reencio	
	2	8000 59844	1	Distanziale	Spacer	Entretoise	Distanzstück	Separador	
	3	8000 34083	1	Anello OR	O-Ring	Bague OR	O-Ring	Anillo OR	
	4	8000 59845	1	Girante	Rotor	Couronne	Laufrad	Rotor	
	5	80A0 82940	1	Coperchio pompa	Pump cover	Couvercle pompe	Pumpendeckel	Tapa bomba	
	6	8000 19965	1	Anello OR	O-Ring	Bague OR	O-Ring	Anillo OR	
	7	8B00 67545	2	Vite	Screw	Vis	Schraube	Tornillo	
	8	8000 92215	1	Radiatore sinistro	Left radiator	Radiateur gauche	Linker Kühler	Radiador izquierdo	
	9	8000 92216	1	Radiatore destro compl.	Right radiator compl.	Radiateur droit compl.	Rechter Kühler kpl.	Radiador derecho compl.	
	10	8000 79077	1	Tappo radiatore	Plug	Bouchon	Verschluss	Tapón	
	11	8B00 43715	1	Tubo sfiato	Pipe	Tuyau	Rohr	Tubo	
	12	8000 59803	6	Gommino	Rubber pad	Pièce caoutchouc	Gummstück	Junta de goma	
	13	8D00 59802	6	Bussola	Bushing	Douille	Buchse	Manguito	
	14	8000 62729	6	Vite	Screw	Vis	Schraube	Tornillo	
	15	8000 59801	6	Rosetta	Washer	Rondelle	Scheibe	Arandela	
	16	8C00 43716	1	Condotto	Pipe	Tuyau	Rohr	Tubo	
	17	8000 56462	2	Fascetta	Clamp	Collier	Schelle	Banda	
	18	8000 94117	2	Condotto	Pipe	Tuyau	Rohr	Tubo	
	19	8000 46881	6	Fascetta	Clamp	Collier	Schelle	Banda	
	20	8A00 73340	2	Condotto	Pipe	Tuyau	Rohr	Tubo	
	21	8000 35751	3	Fascetta	Clamp	Collier	Schelle	Banda	
	22	8000 86887	1	Condotto	Pipe	Tuyau	Rohr	Tubo	
	25	80A0 67248	2	Griglia	Grid	Grille	Rost	Parrilla	
U	27	8000 57205	1	Gancio ritegno cavi	Hook	Crochet	Haken	Gancho	
	28	8000 60873	4	Dado a graffetta	Nut	Ecrou	Mutter	Tuerca	
	29	8AA0 55705	1	Piastrina	Plate	Plateau	Teller	Placa	
	33	8000 64988	1	Rosetta	Washer	Rondelle	Scheibe	Arandela	
	34	8000 62725	1	Vite	Screw	Vis	Schraube	Tornillo	

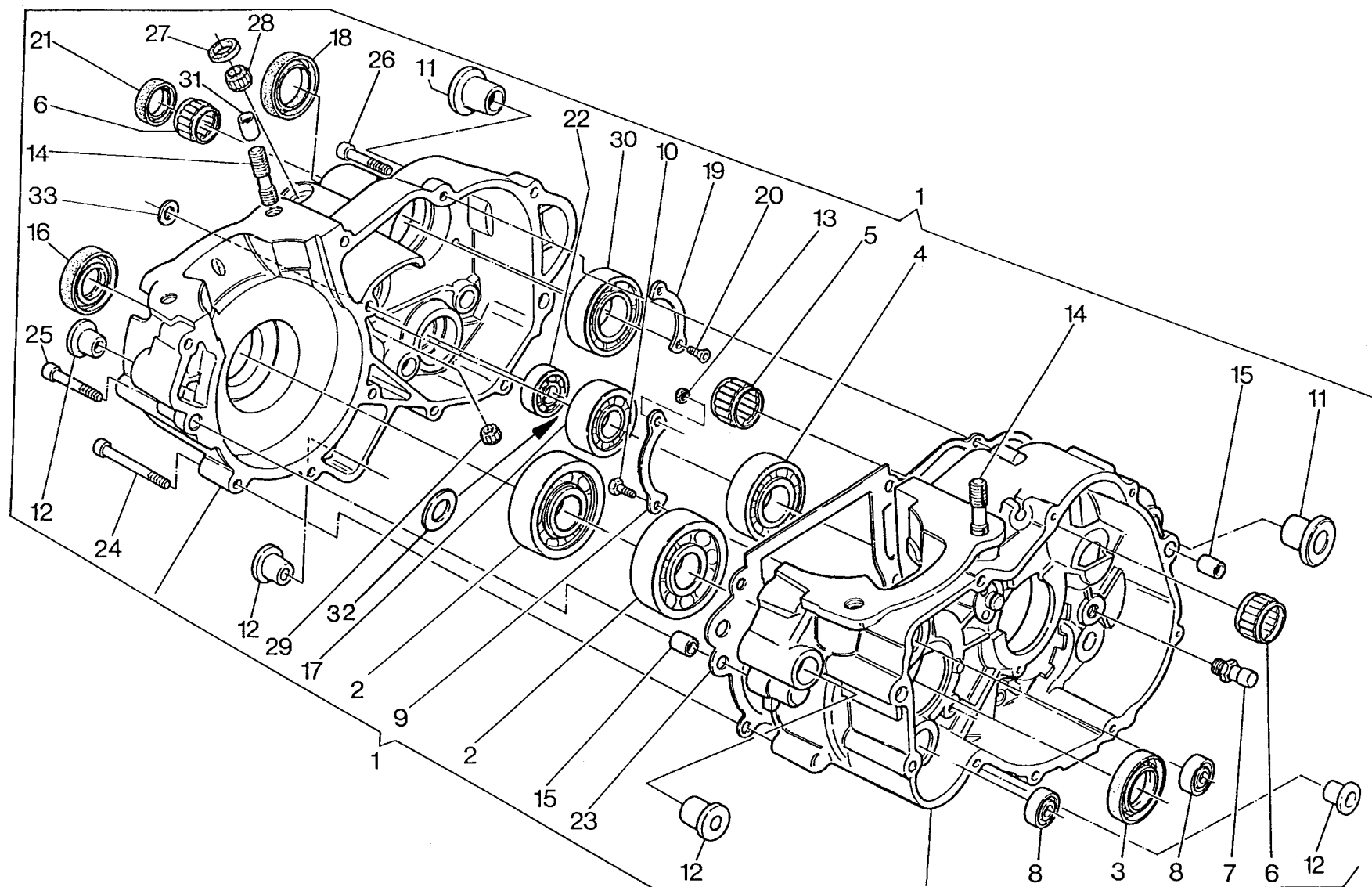



WR - CR 250/2001 ;
WR 360/2001

TAVOLA
DRAWING
TABLE
BILD
TABLA

5

BASAMENTO - CRANKCASE
CARTER - GEHAUSE
BANCADA

Note Notes Notas	Pos. No. Index	N. Cod. Code No. Nr. Code Code Nr N. Cod.	Q.tà Q.ty Q.te M.ge C.ad	DENOMINAZIONE	NAME	DESIGNATION	BESHREIBUNG	DENOMINACION	Validità Validity Validité Gültig Validez
	1	8000 86872	1	Carters motore comp. (250)	Crankcase assy (250)	Carter compl. (250)	Kurberlgehaue kpl. (250)	Carter motor completi (250)	
	1	8000 89368	1	Carters motore comp. (360)	Crankcase assy (360)	Carter compl. (360)	Kurberlgehaue kpl. (360)	Carter motor completi (360)	
	2	8000 42155	2	Cuscinetto albero motore (ø25xø62x17 mm)	Ball bearing (ø25xø62x17 mm)	Roulement à billes (ø25xø62x17 mm)	Kugellager (ø25xø62x17 mm)	Cojinete de bolas (ø25xø62x17 mm)	
	3	8000 30728	1	Anello di tenuta (360) (ø25xø40x7 mm)	Seal ring (360) (ø25xø40x7 mm)	Bague d'étanchéité (360) (ø25xø40x7 mm)	Dichtungsring (360) (ø25xø40x7 mm)	Anillo de retención (360) (ø25xø40x7 mm)	
	3	8000 83590	1	Anello di tenuta (250) (ø32xø40x7 mm)	Seal ring (250) (ø32xø40x7 mm)	Bague d'étanchéité (250) (ø32xø40x7 mm)	Dichtungsring (250) (ø32xø40x7 mm)	Anillo de retención (250) (ø32xø40x7 mm)	
	4	8000 24952	1	Cusc. a sfere (ø25xø52x15 mm)	Ball bearing (ø25xø52x15 mm)	Roulement à billes (ø25xø52x15 mm)	Kugellager (ø25xø52x15 mm)	Cojinete de bolas (ø25xø52x15 mm)	
	5	8000 36440	1	Cusc. a rullini (ø20xø28x13 mm)	Needle bearing (ø20xø28x13 mm)	Roulement à aiguilles (ø20xø28x13 mm)	Nadelkäfig (ø20xø28x13 mm)	Cojinete de rodillos (ø20xø28x13 mm)	
	6	8000 48212	2	Cusc. a rullini (ø20xø26x12 mm)	Needle bearing (ø20xø26x12 mm)	Roulement à aiguilles (ø20xø26x12 mm)	Nadelkäfig (ø20xø26x12 mm)	Cojinete de rodillos (ø20xø26x12 mm)	
	7	8000 46860	1	Perno fermo selettore	Pin	Pivot	Bolzen	Perno	
	8	8000 06597	2	Cuscinetto	Bearing	Roulement	Lager	Cojinete	
	9	8000 42100	1	Piastrina	Plate	Plaquette	Plättchen	Placa	
	10	60N1 01077	1	Vite (360)	Screw (360)	Vis (360)	Schraube (360)	Tornillo (360)	
	10	8H00 67545	1	Vite (250)	Screw (250)	Vis (250)	Schraube (250)	Tornillo (250)	
	11	8000 73500	2	Bussola	Bushing	Douille	Buchse	Manguito	
	12	8000 31717	4	Bussola	Bushing	Douille	Buchse	Manguito	
	13	8000 56409	1	Dado	Nut	Ecrou	Mutter	Tuerca	
	14	8000 42185	4	Prigioniero (M10x64 mm)	Stud bolt (M10x64 mm)	Prisonnier (M10x64 mm)	Stiftschraube (M10x64 mm)	Prisionero (M10x64 mm)	
	15	8000 07719	4	Bussola di riferimento	Bushing	Douille	Buchse	Manguito	
	16	8000 32389	1	Anello di tenuta (ø20xø40x7 mm)	Seal ring (ø20xø40x7 mm)	Bague d'étanchéité (ø20xø40x7 mm)	Dichtungsring (ø20xø40x7 mm)	Anillo de retención (ø20xø40x7 mm)	
	17	8000 78788	1	Cusc. a sfere alb. primario (250) (ø17xø40x8 mm)	Ball bearing (250) (ø17xø40x8 mm)	Roulement à billes (250) (ø17xø40x8 mm)	Kugellager (250) (ø17xø40x8 mm)	Cojinete de bolas (250) (ø17xø40x8 mm)	
F	17	8000 78788	1	Cusc. a sfere alb. primario (360) (ø17xø40x8 mm)	Ball bearing (360) (ø17xø40x8 mm)	Roulement à billes (360) (ø17xø40x8 mm)	Kugellager (360) (ø17xø40x8 mm)	Cojinete de bolas (360) (ø17xø40x8 mm)	
	18	8000 83590	1	Anello di tenuta (ø32xø40x7,5 mm)	Seal ring (ø32xø40x7,5 mm)	Bague d'étanchéité (ø32xø40x7,5 mm)	Dichtungsring (ø32xø40x7,5 mm)	Anillo de retención (ø32xø40x7,5 mm)	

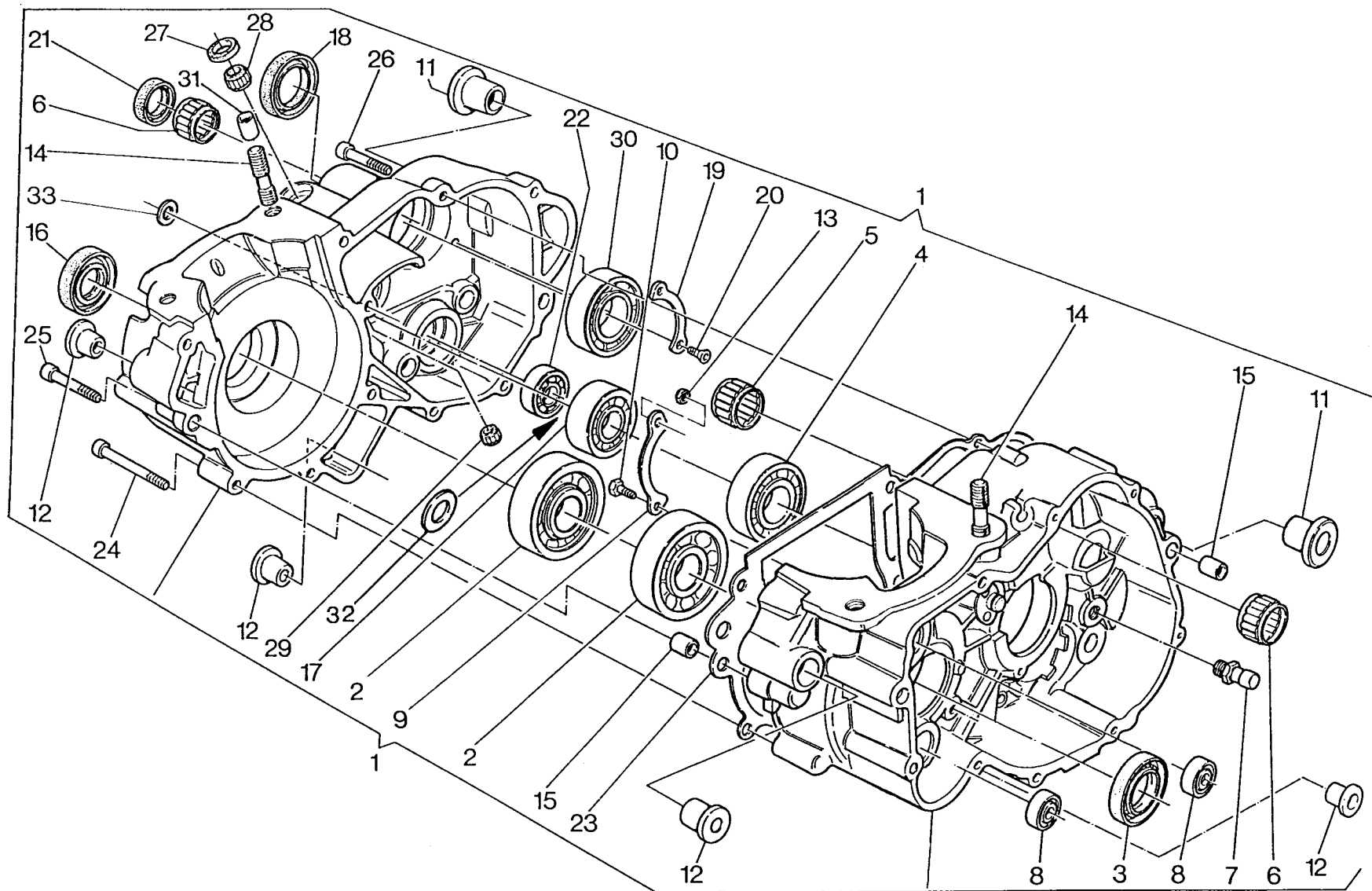



WR - CR 250/2001 ;
WR 360/2001

TAVOLA
DRAWING
TABLE
BILD
TABLA

5

BASAMENTO - CRANKCASE
CARTER - GEHAUSE
BANCADA

Note Notes Notas	Pos. No. Index Pos.	N. Cod. Code No. Nr. Code Code Nr N. Cod.	Q.tà Q.ty Q.te M.ge C.ad	DENOMINAZIONE	NAME	DESIGNATION	BESHREIBUNG	DENOMINACION	Validità Validity Validité Gültig Validez
	19	8000 38518	1	Piastrina	Plate	Plaquette	Plättchen	Placa	
	20	8000 42643	2	Vite (360)	Screw (360)	Vis (360)	Schraube (360)	Tornillo (360)	
	20	8A00 28327	2	Vite (250)	Screw (250)	Vis (250)	Schraube (250)	Tornillo (250)	
	21	8000 48209	1	Anello di tenuta (ø20xø28x6 mm)	Seal ring (ø20xø28x6 mm)	Bague d'étanchéité (ø20xø28x6 mm)	Dichtungsring (ø20xø28x6 mm)	Anillo de retención (ø20xø28x6 mm)	
	22	8000 02124	1	Cusc. a sfere (ø12xø32x10 mm)	Ball bearing (ø12xø32x10 mm)	Roulement à billes (ø12xø32x10 mm)	Kugellager (ø12xø32x10 mm)	Cojinete de bolas (ø12xø32x10 mm)	
	23	8000 72522	1	Guarnizione	Gasket	Garniture	Dichtung	Junta	
	24	60N1 02515	3	Vite (M6x50 mm)	Screw (M6x50 mm)	Vis (M6x50 mm)	Schraube (M6x50 mm)	Tornillo (M6x50 mm)	
	25	60N1 02514	6	Vite (M6x45 mm)	Screw (M6x45 mm)	Vis (M6x45 mm)	Schraube (M6x45 mm)	Tornillo (M6x45 mm)	
	26	60N1 02512	3	Vite (M6x35 mm)	Screw (M6x35 mm)	Vis (M6x35 mm)	Schraube (M6x35 mm)	Tornillo (M6x35 mm)	
	27	8000 48856	1	Anello di tenuta (ø13xø20x4 mm)	Seal ring (ø13xø20x4 mm)	Bague d'étanchéité (ø13xø20x4 mm)	Dichtungsring (ø13xø20x4 mm)	Anillo de retención (ø13xø20x4 mm)	
	28	8000 49016	1	Cuscinetto a rullini (ø13xø19x12 mm)	Needle bearing (ø13xø19x12 mm)	Roulement à aiguilles (ø13xø19x12 mm)	Nadelkäfig (ø13xø19x12 mm)	Cojinete de rodillos (ø13xø19x12 mm)	
	29	8000 42244	1	Cuscinetto a rullini (ø7xø11x9 mm)	Needle bearing (ø7xø11x9 mm)	Roulement à aiguilles (ø7xø11x9 mm)	Nadelkäfig (ø7xø11x9 mm)	Cojinete de rodillos (ø7xø11x9 mm)	
	30	8000 43789	1	Cusc. a rulli albero secondario (ø25xø52x15 mm)	Ball bearing (ø25xø52x15 mm)	Roulement à billes (ø25xø52x15 mm)	Kugellager (ø25xø52x15 mm)	Cojinete de bolas (ø25xø52x15 mm)	
	31	8000 19979	2	Spina di riferimento	Pin	Goupille	Stift	Clavija	
F	32	8H00 28183	1	Rosetta (360)	Washer (360)	Rondelle (360)	Scheibe (360)	Arandela (360)	
	33	1610 82301	1	Rosetta	Washer	Rondelle	Scheibe	Arandela	

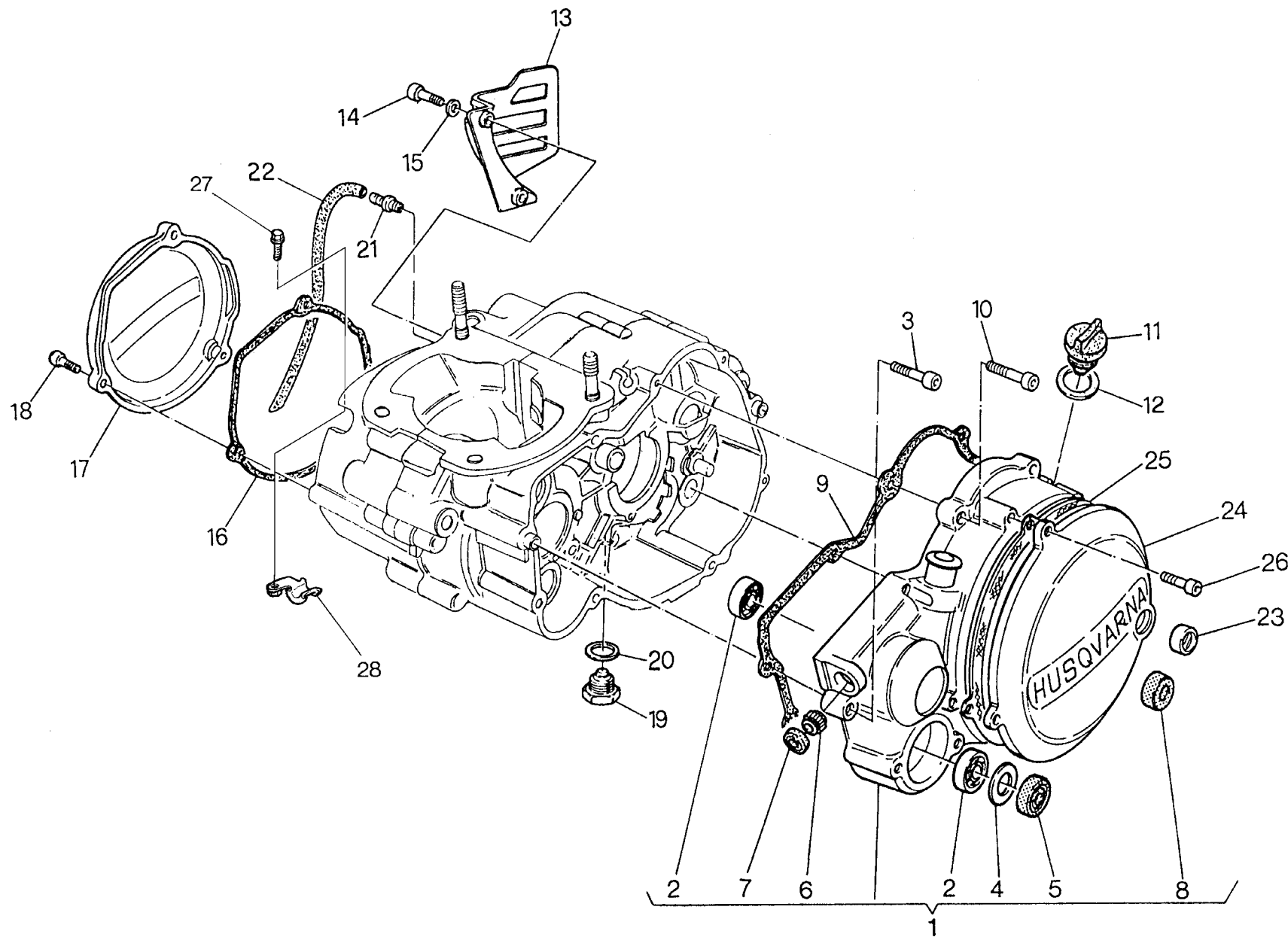



WR 360/2001

TAVOLA
DRAWING
TABLE
BILD
TABLA

6

COPERCHI BASAMENTO - CRANKCASE COVERS
COUVERCLES CARTER - GEHAUSEDECKEL
TAPA BANCADA

Note Notes Notas	Pos. No. Index Pos.	N. Cod. Code No. Nr. Code Code Nr N. Cod.	Q.tà Q.ty Q.te M.ge C.ad	DENOMINAZIONE	NAME	DESIGNATION	BESHREIBUNG	DENOMINACION	Validità Validity Validité Gültig Validez
	1	80A0 60288	1	Coperchio sinistro completo	Left cover assembly	Ensemble couvercle G.	Aggregat Dekel L.	Juego tapa izq.	
	2	8000 06597	2	Cuscinetto a sfere (ø8xØ22x7 mm)	Ball bearing (ø8xØ22x7 mm)	Roulement à billes (ø8xØ22x7 mm)	Kugellager (ø8xØ22x7 mm)	Cojinete de bolas (ø8xØ22x7 mm)	
	3	60N1 02511	2	Vite (M6x30 mm)	Screw (M6x30 mm)	Vis (M6x30 mm)	Schraube (M6x30 mm)	Tornillo (M6x30 mm)	
	4	8000 44978	1	Rosetta piana	Washer	Rondelle	Scheibe	Arandela	
	5	8000 38215	1	Anello di tenuta (ø15xØ24x7 mm)	Seal ring (ø15xØ24x7 mm)	Bague d'étanchéité (ø15xØ24x7 mm)	Dichtungsring (ø15xØ24x7 mm)	Anillo de retención (ø15xØ24x7 mm)	
	6	8000 31748	1	Cuscinetto a rullini (ø8xØ12x10 mm)	Needle bearing (ø8xØ12x10 mm)	Roulement à aiguilles (ø8xØ12x10 mm)	Nadelkäfig (ø8xØ12x10 mm)	Cojinete de rodillos (ø8xØ12x10 mm)	
	7	8000 64296	1	Anello di tenuta (ø8xØ16x5 mm)	Seal ring (ø8xØ16x5 mm)	Bague d'étanchéité (ø8xØ16x5 mm)	Dichtungsring (ø8xØ16x5 mm)	Anillo de retención (ø8xØ16x5 mm)	
	8	8000 34451	1	Anello di tenuta (ø12xØ19x5 mm)	Seal ring ø12xØ19x5mm	Bague d'étanchéité (ø12xØ19x5 mm)	Dichtungsring (ø12xØ19x5 mm)	Anillo de retención (ø12xØ19x5 mm)	
	9	8000 48216	1	Guarnizione	Gasket	Garniture	Dichtung	Junta	
	10	60N1 02509	6	Vite (M6x20 mm)	Screw (M6x20 mm)	Vis (M6x20 mm)	Schraube (M6x20 mm)	Tornillo (M6x20 mm)	
	11	8000 36786	1	Tappo carico olio	Oil filling cap	Bouchon rempl. huile	Öleinfüllstöpsel	Tapón intruducción aceite	
	12	8000 27960	1	Rosetta di tenuta	Washer	Rondelle	Scheibe	Arandela	
	13	8A00 57002	1	Coperchio pignone	Cover	Couvercle	Deckel	Tapa	
	14	60N1 07335	2	Vite	Screw	Vis	Schraube	Tornillo	
	15	62N2 15504	2	Rosetta piana	Washer	Rondelle	Scheibe	Arandela	
	16	8000 69372	1	Guarnizione	Gasket	Garniture	Dichtung	Junta	
	17	80A0 69144	1	Coperchio volano	Cover	Couvercle	Deckel	Tapa	
	18	60N1 02509	3	Vite (M6x20 mm)	Screw (M6x20 mm)	Vis (M6x20 mm)	Schraube (M6x20 mm)	Tornillo (M6x20 mm)	
	19	8000 11524	1	Tappo scarico olio	Oil drain plug	Bouchon vidange huile	Stöpsel f. ölablass	Tapón purga aceite	
	20	8B00 06725	1	Rosetta di tenuta	Washer	Rondelle	Scheibe	Arandela	
	21	8000 19620	1	Raccordo sfiato camera cambio	Union	Raccord	Anschluss	Empalme	
	22	8000 45022	1	Tubo	Pipe	Tuyau	Rohr	Tubo	
	23	8000 53340	1	Spia livello olio	Oil inspection cap	Bouchon controle huile	Oelstandkontrolle	Mirilla nivel aceite	
	24	80A0 63618	1	Coperchio frizione	Clutch cover	Couvercle embrayage	Kupplungsdeckel	Tapa accionamiento embrague	
	25	8000 59603	1	Guarnizione	Gasket	Garniture	Dichtung	Junta	
	26	60N1 02506	5	Vite (M6x14 mm)	Screw (M6x14 mm)	Vis (M6x14 mm)	Schraube (M6x14 mm)	Tornillo (M6x14 mm)	
	27	8E00 67997	1	Vite	Screw	Vis	Schraube	Tornillo	
	28	8000 89353	1	Piastrina	Plate	Plaquette	Plättchen	Placa	

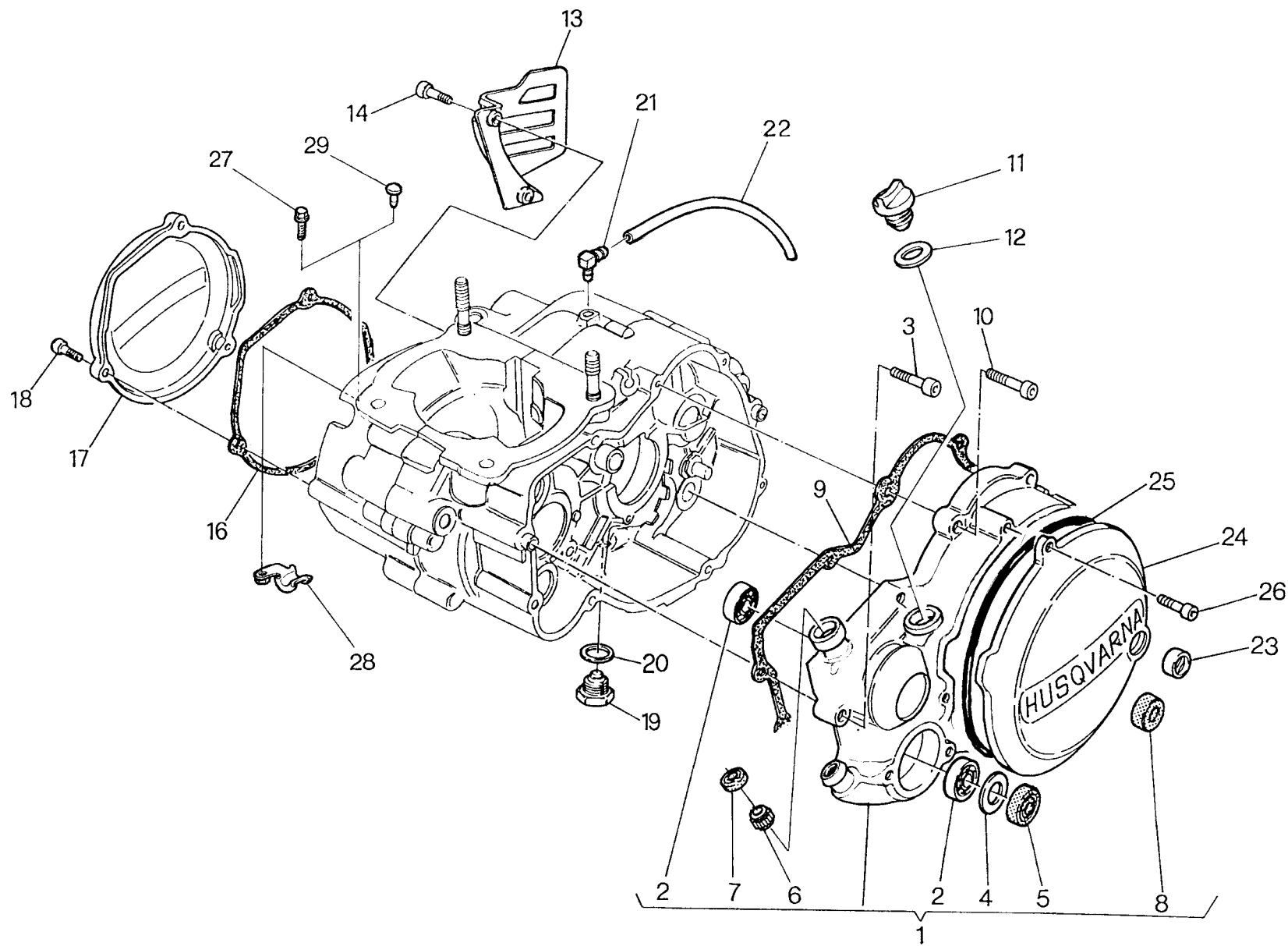



WR - CR 250/2001

TAVOLA
DRAWING
TABLE
BILD
TABLA

6A

COPERCHI BASAMENTO - CRANKCASE COVERS
COUVERCLES CARTER - GEHAUSEDECKEL
TAPA BANCADA

Note Notes Notas	Pos. No. Index Pos.	N. Cod. Code No. Nr. Code Code Nr N. Cod.	Q.tà Q.ty Q.te M.ge C.ad	DENOMINAZIONE	NAME	DESIGNATION	BESHREIBUNG	DENOMINACION	Validità Validity Validité Gültig Validez
	1	80A0 86875	1	Coperchio sinistro completo	Left cover assembly	Ensemble couvercle G.	Aggregat Dekel L.	Juego tapa izq.	
	2	8000 06597	2	Cuscinetto a sfere (ø8xØ22x7 mm)	Ball bearing (ø8xØ22x7 mm)	Roulement à billes (ø8xØ22x7 mm)	Kugellager (ø8xØ22x7 mm)	Cojinete de bolas (ø8xØ22x7 mm)	
	3	8A00 67545	2	Vite L = 35 mm	Screw	Vis	Schraube	Tornillo	
	4	8000 44978	1	Rosetta piana	Washer	Rondelle	Scheibe	Arandela	
	5	8000 38215	1	Anello di tenuta (ø15xØ24x7 mm)	Seal ring (ø15xØ24x7 mm)	Bague d'étanchéité (ø15xØ24x7 mm)	Dichtungsring (ø15xØ24x7 mm)	Anillo de retención (ø15xØ24x7 mm)	
	6	8000 47678	2	Cuscinetto a rullini	Needle bearing	Roulement à aiguilles	Nadelkäfig	Cojinete de rodillos	
	7	8000 19177	1	Anello di tenuta (ø8xØ13x3,5 mm)	Seal ring (ø8xØ13x3,5 mm)	Bague d'étanchéité (ø8xØ13x3,5 mm)	Dichtungsring (ø8xØ13x3,5 mm)	Anillo de retención (ø8xØ13x3,5 mm)	
	8	8000 34451	1	Anello di tenuta (ø12xØ19x5 mm)	Seal ring (ø12xØ19x5 mm)	Bague d'étanchéité (ø12xØ19x5 mm)	Dichtungsring (ø12xØ19x5 mm)	Anillo de retención (ø12xØ19x5 mm)	
	9	8000 48216	1	Guarnizione	Gasket	Garniture	Dichtung	Junta	
	10	8000 62729	6	Vite (L = 25 mm)	Screw (L = 25 mm)	Vis (L = 25 mm)	Schraube (L = 25 mm)	Tornillo (L = 25 mm)	
	11	8000 36786	1	Tappo carico olio	Oil filling cap	Bouchon rempl. huile	Öleinfüllstöpsel	Tapón intruducción aceite	
	12	8000 27960	1	Rosetta di tenuta	Washer	Rondelle	Scheibe	Arandela	
	13	8000 82939	1	Coperchio pignone	Cover	Couvercle	Deckel	Tapa	
	14	8000 62727	2	Vite (L=16)	Screw (L=16)	Vis (L=16)	Schraube (L=16)	Tornillo (L=16)	
	16	8000 69372	1	Guarnizione	Gasket	Garniture	Dichtung	Junta	
	17	80A0 82930	1	Coperchio volano	Cover	Couvercle	Deckel	Tapa	
	18	8000 62728	3	Vite (L = 20 mm)	Screw (L = 20 mm)	Vis (L = 20 mm)	Schraube (L = 20 mm)	Tornillo (L = 20 mm)	
	19	8000 11524	1	Tappo scarico olio	Oil drain plug	Bouchon vidange huile	Stöpsel f. ölablass	Tapón purga aceite	
	20	8B00 06725	1	Rosetta di tenuta	Washer	Rondelle	Scheibe	Arandela	
	21	8000 19620	1	Raccordo sfiato camera cambio	Union	Raccord	Anschluss	Empalme	
	22	8000 45022	1	Tubo	Pipe	Tuyau	Rohr	Tubo	
	23	8000 53340	1	Spia livello olio	Oil inspection cap	Bouchon controle huile	Oelstandkontrolle	Mirilla nivel aceite	
	24	80A0 86877	1	Coperchio frizione	Clutch cover	Couvercle embrayage	Kupplungsdeckel	Tapa accionamiento embrague	
	25	8000 86878	1	Guarnizione	Gasket	Garniture	Dichtung	Junta	
	26	8000 62728	5	Vite (L = 20 mm)	Screw (L = 20 mm)	Vis (L = 20 mm)	Schraube (L = 20 mm)	Tornillo (L = 20 mm)	
Y	27	8E00 67997	1	Vite	Screw	Vis	Schraube	Tornillo	
Y	28	8000 89353	1	Piastrina	Plate	Plaquette	Plättchen	Placa	
C	29	8000 58394	1	Tappo	Plug	Bouchon	Verschluss	Tapa	

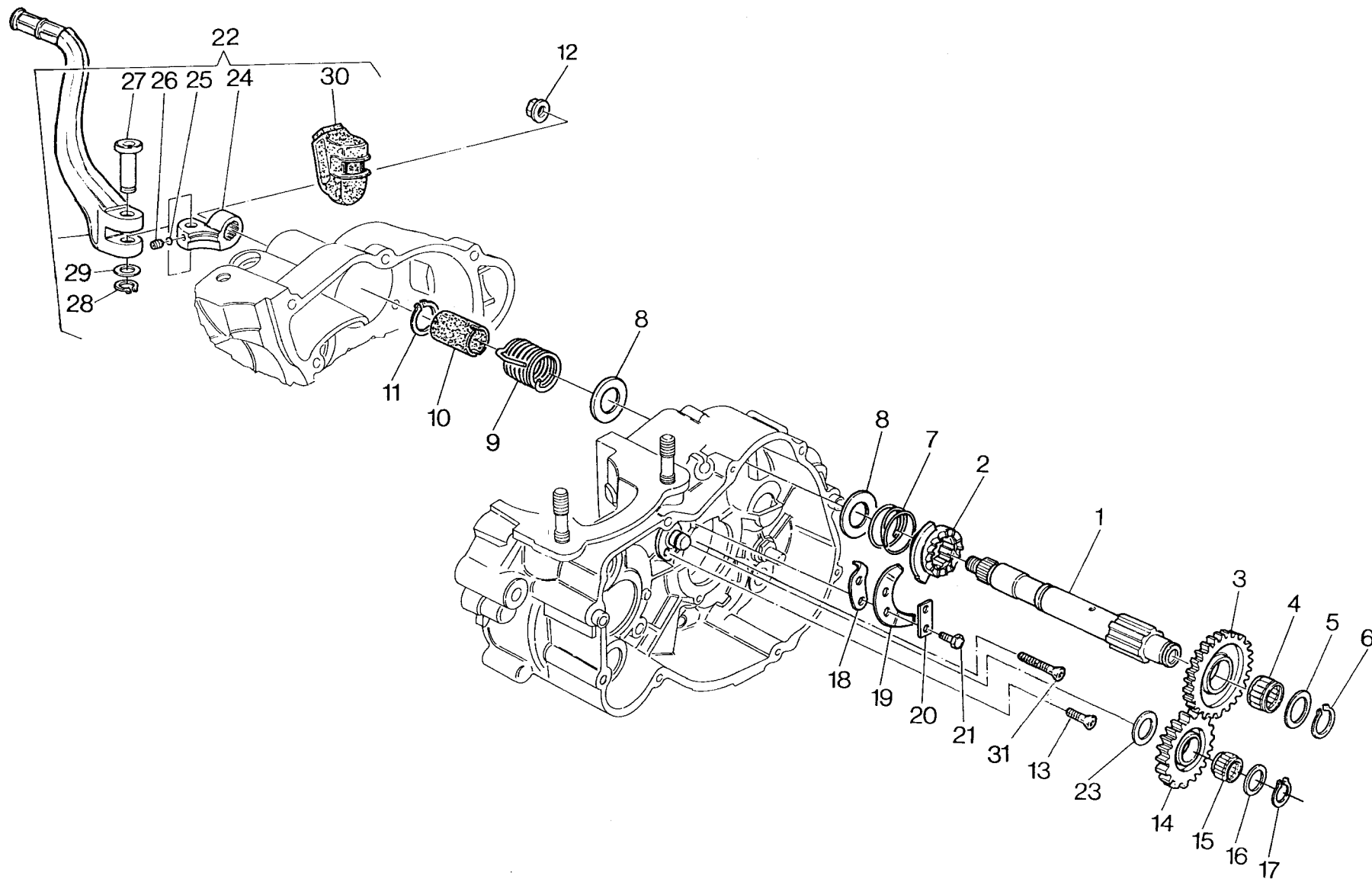



WR - CR 250/2001 ;
WR 360/2001

TAVOLA
DRAWING
TABLE
BILD
TABLA

7

AVVIAMENTO A PEDALE - KICK STARTER
PEDAL DE MISE EN MARCHE - ANLASSER
PUESTA EN MARCHA A PEDAL

Note Notes Notas	Pos. No. Index Pos.	N. Cod. Code No. Nr. Code Code Nr N. Cod.	Q.tà Q.ty Q.te M.ge C.ad	DENOMINAZIONE	NAME	DESIGNATION	BESHREIBUNG	DENOMINACION	Validità Validity Validité Gültig Validez
	1	8000 48110	1	Albero avviamento (360)	Starter crank shaft (360)	Arbre de démarrage (360)	Kickstarterwelle (360)	Eje arranque (360)	
	1	8000 90617	1	Albero avviamento (250)	Starter crank shaft (250)	Arbre de démarrage (250)	Kickstarterwelle (250)	Eje arranque (250)	
	2	8000 48111	1	Manicotto scorrevole	Sleeve	Manchon	Muffe	Manguito	
	3	8000 48112	1	Ingr. con cricchetto (Z = 27)	Gear (Z = 27)	Engrange (Z = 27)	Zahnrad (Z = 27)	Engranaje (Z = 27)	
	4	8000 48113	1	Cuscinetto a rullini (ø18xØ22x8 mm)	Needle bearing (ø18xØ22x8 mm)	Roulement à aiguilles (ø18xØ22x8 mm)	Nadelkäfig (ø18xØ22x8 mm)	Cojinete de rodillos (ø18xØ22x8 mm)	
	5	8000 48114	1	Rosetta di rasamento	Washer	Rondelle	Scheibe	Arandela	
	6	66N0 21207	1	Anello elastico	Split ring	Anneau ressort	Sprengring	Anillo elástico	
	7	8000 48115	1	Molla	Spring	Ressort	Feder	Resorte	
	8	8E00 32069	2	Rosetta di rasamento (1,0 mm)	Washer (1,0 mm)	Rondelle (1,0 mm)	Scheibe (1,0 mm)	Arandela (1,0 mm)	
	8	8D00 32069	2	Rosetta di rasamento (0,8 mm)	Washer (0,8 mm)	Rondelle (0,8 mm)	Scheibe (0,8 mm)	Arandela (0,8 mm)	
	8	8000 32069	2	Rosetta di rasamento (0,3 mm)	Washer (0,3 mm)	Rondelle (0,3 mm)	Scheibe (0,3 mm)	Arandela (0,3 mm)	
	9	8000 48116	1	Molla	Spring	Ressort	Feder	Resorte	
	10	8000 48117	1	Distanziale	Spacer	Entretoise	Distanzstück	Separador	
	11	66N0 21208	1	Anello elastico	Splitring	Anneau ressort	Sprengring	Anillo elástico	
	12	8000 38624	1	Dado	Nut	Ecrou	Mutter	Tuerca	
	13	8000 28327	1	Vite	Screw	Vis	Schraube	Tornillo	
	14	8000 57542	1	Ingranaggio di rinvio (Z = 20)	Gear (Z = 20)	Engrange (Z = 20)	Zahnrad (Z = 20)	Engranaje (Z = 20)	
	15	8000 31773	1	Cuscinetto a rullini (ø16xØ20x8 mm)	Needle bearing (ø16xØ20x8 mm)	Roulement à aiguilles (ø16xØ20x8 mm)	Nadelkäfig (ø16xØ20x8 mm)	Cojinete de rodillos (ø16xØ20x8 mm)	
	16	8A00 38110	1	Rosetta di rasamento (0,4 mm)	Washer (0,4 mm)	Rondelle (0,4 mm)	Scheibe (0,4 mm)	Arandela (0,4 mm)	
	16	8B00 38110	1	Rosetta di ras. (0,5 mm) (360)	Washer (0,5 mm) (360)	Rondelle (0,5 mm) (360)	Scheibe (0,5 mm) (360)	Arandela (0,5 mm) (360)	
	16	8D00 38110	1	Rosetta di rasamento (0,8 mm)	Washer (0,8 mm)	Rondelle (0,8 mm)	Scheibe (0,8 mm)	Arandela (0,8 mm)	
	17	66N0 21205	1	Anello elastico	Splitring	Anneau ressort	Sprengring	Anillo elástico	
	18	8000 31695	1	Piastrina fine corsa	Plate	Plaquette	Plättchen	Placa final de carrera	
	19	8000 55536	1	Piastrina disinnesto	Plate	Plaquette	Plättchen	Placa	
	20	8000 20474	1	Piastrina di sicurezza	Plate	Plaquette	Plättchen	Placa	
	21	60N1 01883	2	Vite	Screw	Vis	Schraube	Tornillo	
	22	8A00 69786	1	Leva avviamento compl. (360)	Starter lever assy (360)	Levier démarrage compl. (360)	Hebelanlasser kpl. (360)	Palanca arranque compl. (360)	
	22	8000 89996	1	Leva avviamento compl. (250)	Starter lever assy (250)	Levier démarrage compl. (250)	Hebelanlasser kpl. (250)	Palanca arranque compl. (250)	
	23	8000 38110	1	Rosetta di rasamento (0,3 mm)	Washer (0,3 mm)	Rondelle (0,3 mm)	Scheibe (0,3 mm)	Arandela (0,3 mm)	
	23	8B00 38110	1	Rosetta di rasamento (0,5 mm)	Washer (0,5 mm)	Rondelle (0,5 mm)	Scheibe (0,5 mm)	Arandela (0,5 mm)	

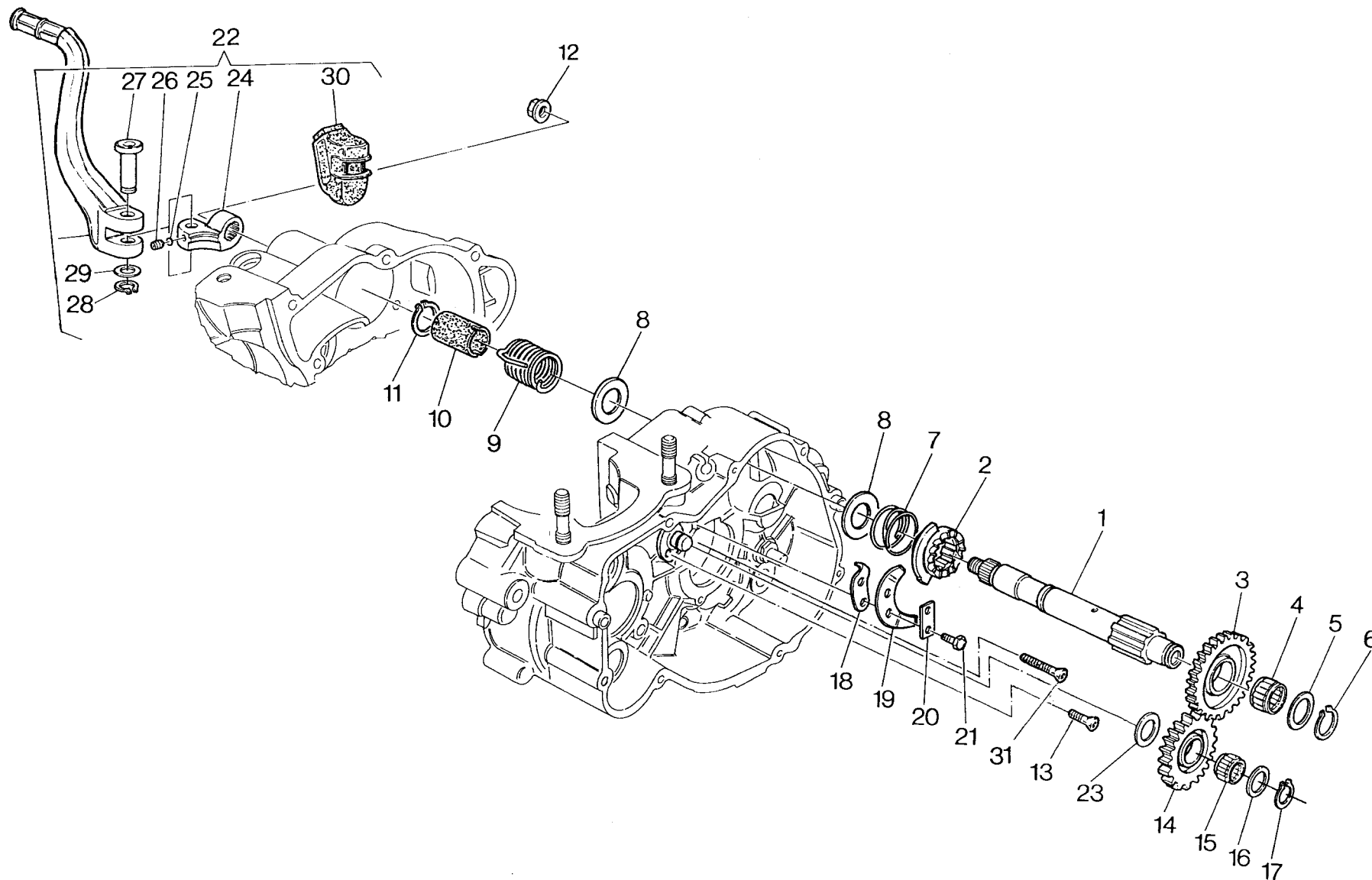



WR - CR 250/2001 ;
WR 360/2001

TAVOLA
DRAWING
TABLE
BILD
TABLA

7

AVVIAMENTO A PEDALE - KICK STARTER
PEDAL DE MISE EN MARCHE - ANLASSER
PUESTA EN MARCHA A PEDAL

Note Notes Marke Notas	Pos. No. Index Pos.	N. Cod. Code No. Nr. Code Code Nr N. Cod.	Q.tà Q.ty Q.te M.ge C.ad	DENOMINAZIONE	NAME	DESIGNATION	BESHREIBUNG	DENOMINACION	Validità Validity Validité Gültig Validéz
	24	8000 48122	1	Mozzetto (360)	Hub (360)	Moyeau (360)	Radnabe (360)	Cubo (360)	
	24	8000 89998	1	Mozzetto (250)	Hub (250)	Moyeau (250)	Radnabe (250)	Cubo (250)	
	25	6BN0 21507	1	Sfera (1/4")	Ball (1/4")	Bille (1/4")	Kugel (1/4")	Esfera (1/4")	
	26	8000 32203	1	Molla	Spring	Ressort	Feder	Resorte	
	27	8000 38622	1	Perno	Pin	Pivot	Bolzen	Perno	
	28	66N0 21202	1	Anello elastico	Split ring	Anneau ressort	Sprengring	Anillo elástico	
	29	8000 09671	1	Rosetta piana	Washer	Rondelle	Scheibe	Arandela	
	30	8000 38623	1	Cappuccio	Cap	Capuchon	Kappe	Capuchón	
	31	8000 53876	1	Vite	Screw	Vis	Schraube	Tornillo	

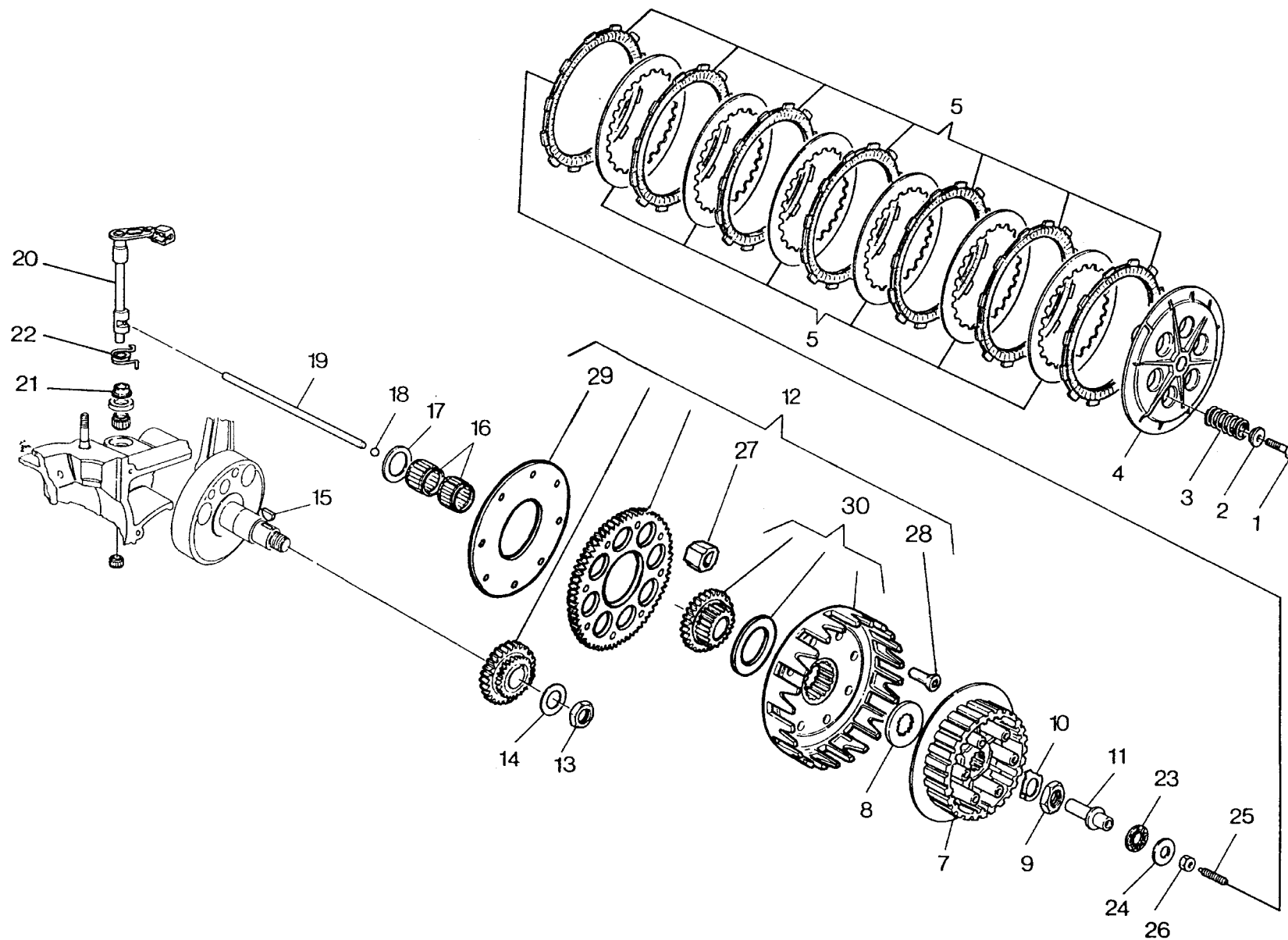



WR 360/2001

TAVOLA
DRAWING
TABLE
BILD
TABLA

8

FRIZIONE, TRASM. PRIMARIA - CLUTCH, PRIMARY DRIVE
EMBAYAGE, TRANSMISS. PRIMARIE - KUPPLUNG, ERSTERANTRIEB
ENBRAGUE, TRANSM. PRIMARIA

Note Notes Notas	Pos. No. Index Pos.	N. Cod. Code No. Nr. Code Code Nr N. Cod.	Q.tà Q.ty Q.te M.ge C.ad	DENOMINAZIONE	NAME	DESIGNATION	BESHREIBUNG	DENOMINACION	Validità Validity Validité Gültig Validez
	1	60N1 01081	6	Vite	Screw	Vis	Schraube	Tornillo	
	2	8000 39248	6	Piattello	Plate	Plateau	Teller	Placa	
	3	8000 71230	6	Molla	Spring	Ressort	Feder	Resorte	
	4	8000 48138	1	Piattospingidisci	Pressure plate	Pousse disque	Druckplatte	Plato empuja-disco	
	5	8000 95243	1	Ass. gruppo frizione	Clutch group assy	Groupe embrayage compl.	Kupplungsgruppe Kpl.	Grupo embrague compl.	
	7	8A00 48137	1	Mozzo portadisci	Clutch hub	Moyeu porte-disque	Scheibenhalmabe	Porta-discos	
	8	8000 38350	1	Rosetta di spallamento	Washer	Rondelle	Scheibe	Arandela	
	9	8000 36856	1	Dado	Nut	Ecrou	Mutter	Tuerca	
	10	8000 36857	1	Rosetta di sicurezza	Washer	Rondelle	Scheibe	Arandela	
	11	8000 54477	1	Piattello	Plate	Plateau	Teller	Placa	
	12	8000 63389	1	Coppia ingr. trasm. primaria (z25/60)	Set of matched primary (z25/60)	Engrenages trans. prim. (z25/60)	Stirnradpaar (z 25/60)	Copla engranaje primaria (z 25/60)	
	13	8000 36856	1	Dado	Nut	Ecrou	Mutter	Tuerca	
	14	8000 48238	1	Rosetta a tazza	Washer	Rondelle	Scheibe	Arandela	
	15	65N0 21010	1	Linguetta americana	Woodruff key	Clé woodruff	Federkeil	Lengüeta americana	
	16	8000 25044	2	Gabbia a rullini (ø24xØ28x13 mm)	Needle cage (ø24xØ28x13 mm)	Cage à aiguilles (ø24xØ28x13 mm)	Nadelkaefig (ø24xØ28x13 mm)	Jaula de agujas del cojinete (ø24xØ28x13 mm)	
	17	8000 48239	1	Rosetta di rasamento (1,1 mm)	Washer (1,1 mm)	Rondelle (1,1 mm)	Scheibe (1,1 mm)	Arandela (1,1 mm)	
	17	8A00 48239	1	Rosetta di rasamento (1,3 mm)	Washer (1,3 mm)	Rondelle (1,3 mm)	Scheibe (1,3 mm)	Arandela (1,3 mm)	
	17	8B00 48239	1	Rosetta di rasamento (1,5 mm)	Washer (1,5 mm)	Rondelle (1,5 mm)	Scheibe (1,5 mm)	Arandela (1,5 mm)	
	18	6BN0 21508	1	Sfera (9/32")	Ball (9/32")	Bille (9/32")	Kugel (9/32")	Esfera (9/32")	
	19	8000 59913	1	Astina disinnesto	Control rod	Coulisseau	Steuerstange	Varilla	
	20	8000 61115	1	Albero comando frizione	Shaft	Arbre	Welle	Eje	
	21	8000 55532	1	Bussola	Bushing	Douille	Buchse	Manguito	
	22	8000 48188	1	Molla	Spring	Ressort	Feder	Resorte	
	23	8000 35780	1	Cuscinetto assiale	Bearing	Roulement	Lager	Cojinete	
	24	8000 35781	1	Ralla	Washer	Rondelle	Scheibe	Arandela	
	25	8000 54692	1	Vite di registro	Adjusting screw	Vis de réglage	Verstellungsschraube	Tornillo de regulación	
	26	60N1 15033	1	Dado	Nut	Ecrou	Mutter	Tuerca	
	27	8000 48235	8	Parastrappi	Flexible coupling	Piece caoutchouc	Gumidämpfer	Paratirones	
	28	8000 48236	8	Ribattino	Rivet	Rivet	Niet	Remache	
	29	8000 48234	1	Disco ritegno ingr. condotto	Drive gear retaining disc	Disque	Scheibe	Disco	
	30	8000 48231	1	Ass. custodia frizione compl.	Clutch housing compl.	Cage embrayage compl.	Kupplungskorb Kpl.	Campana embrague compl.	

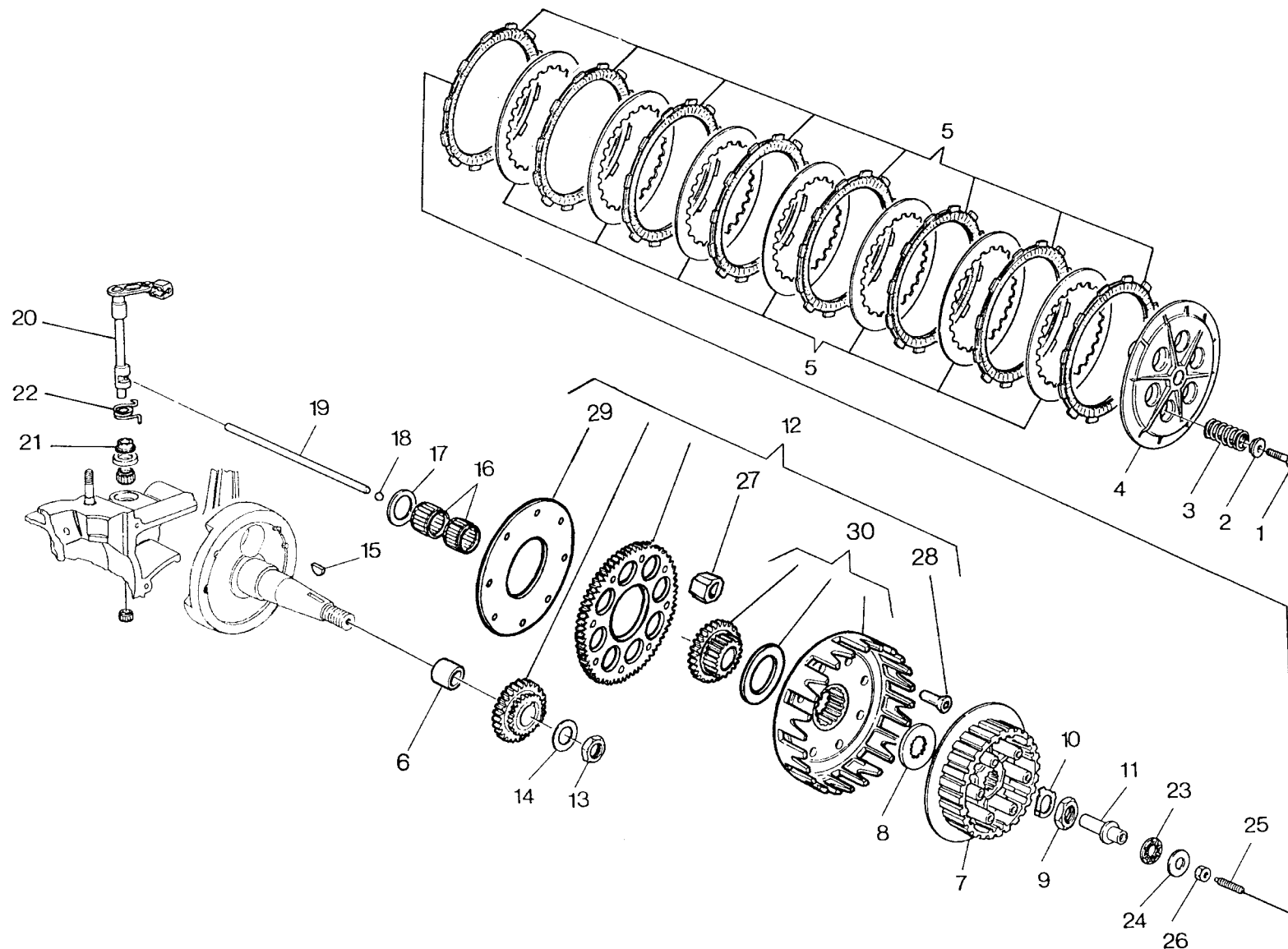

Note Notes Notas	Pos. No. Index Pos.	N. Cod. Code No. Nr. Code Code Nr N. Cod.	Q.tà Q.ty Q.te M.ge C.ad	DENOMINAZIONE	NAME	DESIGNATION	BESHREIBUNG	DENOMINACION	Validità Validity Validité Gültig Validez
	1	8000 62728	6	Vite	Screw	Vis	Schraube	Tornillo	
	2	8A00 39248	6	Piattello	Plate	Plateau	Teller	Placa	
	3	8000 86880	6	Molla	Spring	Ressort	Feder	Resorte	
	4	8000 48138	1	Piattospingidisci	Pressure plate	Pousse disque	Druckplatte	Plato empuja-disco	
	5	8000 88966	1	Ass. gruppo frizione	Clutch group assy	Groupe embrayage compl.	Kupplungsgruppe Kpl.	Grupo embrague compl.	
	6	8A00 82467	1	Distanziale	Spacer	Entretoise	Distanzstück	Separador	
	7	8000 85390	1	Mozzo portadisci	Clutch hub	Moyeu porte-disque	Scheibenhalmabe	Porta-discos	
	8	8000 38350	1	Rosetta di spallamento	Washer	Rondelle	Scheibe	Arandela	
	9	8000 36856	1	Dado	Nut	Ecrou	Mutter	Tuerca	
	10	8000 36857	1	Rosetta di sicurezza	Washer	Rondelle	Scheibe	Arandela	
	11	8000 54477	1	Piattello	Plate	Plateau	Teller	Placa	
	12	8000 86860	1	Coppia ingr. trasm. primaria (z27/69)	Set of matched primary (z27/69)	Engrenages trans. prim. (z27/69)	Stirnradpaar (z 27/69)	Copla engranaje primaria (z27/69)	
	13	8000 36856	1	Dado	Nut	Ecrou	Mutter	Tuerca	
	14	8000 48238	1	Rosetta a tazza	Washer	Rondelle	Scheibe	Arandela	
	15	65N0 21010	1	Linguetta americana	Woodruff key	Clé woodruff	Federkeil	Lengüeta americana	
	16	8000 25044	2	Gabbia a rullini	Needle cage	Cage à aiguilles	Nadelkaefig	Jaula de agujas del cojinete	
	17	8000 48239	1	Rosetta di rasamento (1,1 mm)	Washer (1,1 mm)	Rondelle (1,1 mm)	Scheibe (1,1 mm)	Arandela (1,1 mm)	
	17	8A00 48239	1	Rosetta di rasamento (1,3 mm)	Washer (1,3 mm)	Rondelle (1,3 mm)	Scheibe (1,3 mm)	Arandela (1,3 mm)	
	17	8B00 48239	1	Rosetta di rasamento (1,5 mm)	Washer (1,5 mm)	Rondelle (1,5 mm)	Scheibe (1,5 mm)	Arandela (1,5 mm)	
	18	6BN0 21508	1	Sfera (9/32")	Ball (9/32")	Bille (9/32")	Kugel (9/32")	Esfera (9/32")	
	19	8A00 59913	1	Astina disinnesto	Control rod	Coulisseau	Steuerstange	Varilla	
	20	8000 61115	1	Albero comando frizione	Shaft	Arbre	Welle	Eje	
	21	8000 55532	1	Bussola	Bushing	Douille	Buchse	Manguito	
	22	8000 48188	1	Molla	Spring	Ressort	Feder	Resorte	
	23	8000 35780	1	Cuscinetto assiale	Bearing	Roulement	Lager	Cojinete	
	24	8000 35781	1	Ralla	Washer	Rondelle	Scheibe	Arandela	
	25	8000 54692	1	Vite di registro	Adjusting screw	Vis de réglage	Verstellungsschraube	Tornillo de regulación	
	26	60N1 15033	1	Dado	Nut	Ecrou	Mutter	Tuerca	
	27	8000 48235	8	Parastrappi	Flexible coupling	Piece caoutchouc	Gumidämpfer	Paratirones	
	28	8000 48236	8	Ribattino	Rivet	Rivet	Niet	Remache	
	29	8000 48234	1	Disco ritegno ingr. condotto	Drive gear retaining disc	Disque	Scheibe	Disco	
	30	8000 86862	1	Ass. custodia frizione compl.	Clutch housing compl.	Cage embrayage compl.	Kupplungskorb Kpl.	Campana embrague compl.	

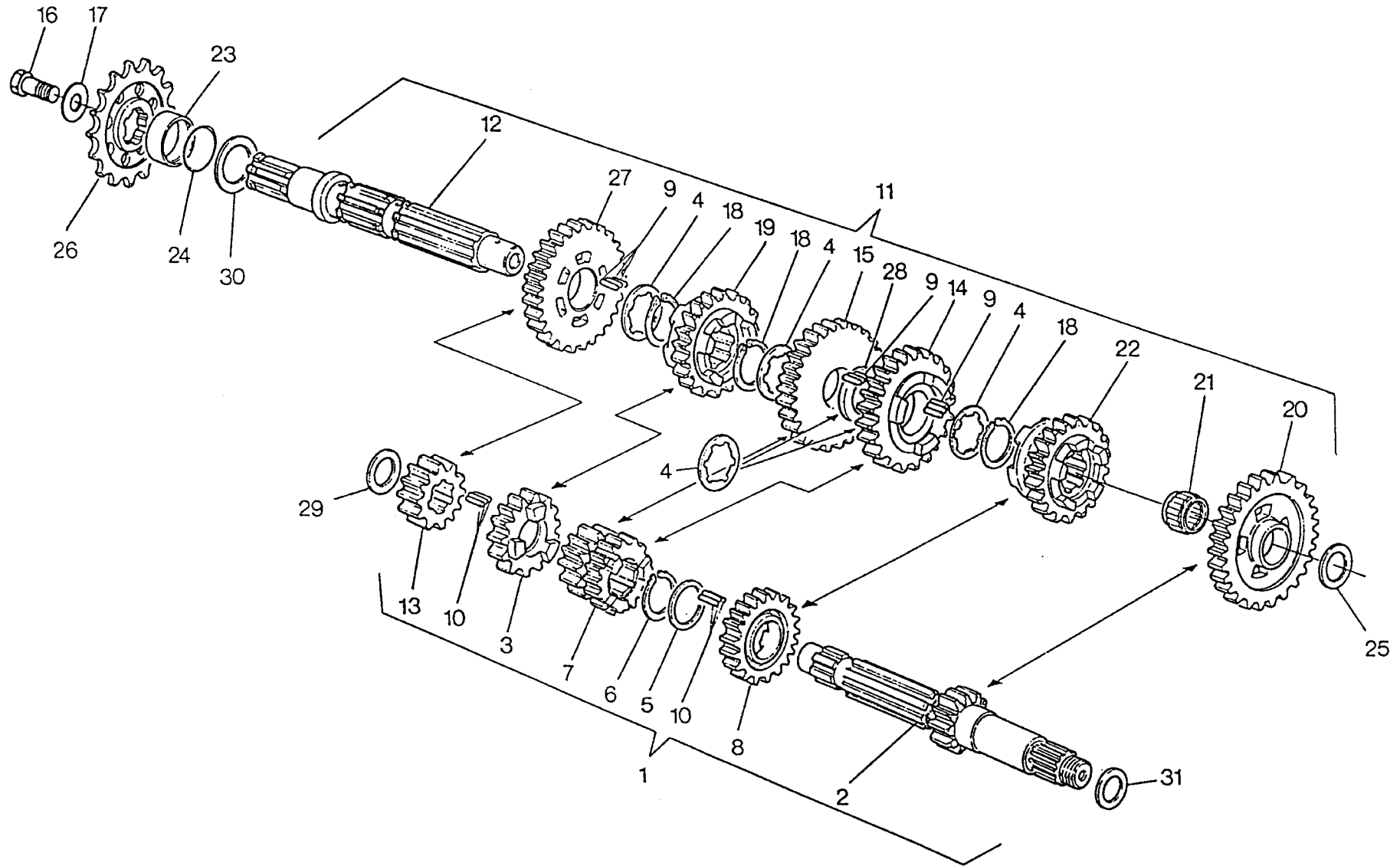



WR 360/2001

TAVOLA
DRAWING
TABLE
BILD
TABLA

9

CAMBIO - TRANSMISSION
BOITE DE VITESSE - WECHSELGETRIEBE
CAMBIO

Note Notes Notas	Pos. No. Index Pos.	N. Cod. Code No. Nr. Code Code Nr N. Cod.	Q.tà Q.ty Q.te M.ge C.ad	DENOMINAZIONE	NAME	DESIGNATION	BESHREIBUNG	DENOMINACION	Validità Validity Validité Gültig Validéz
	1	8000 63623	1	Albero primario completo	Main shaft	Arbre primaire	Hauptwelle	Eje principal completo	
	2	8000 59691	1	Albero primario (Z=11)	Main shaft (Z=11)	Arbre primaire (Z=11)	Hauptwelle (Z=11)	Eje primario (Z=11)	
	3	8000 63627	1	Ingr. 6ª velocità (Z=20)	Gear 6th speed (Z=20)	Engrimage 6ème (Z=20)	Zahnrad 6. Gang (Z=20)	Engranaje 6º velocidad (Z=20)	
	4	8A00 36889	5	Rosetta di rasamento (1,2 mm)	Washer (1,2 mm)	Rondelle (1,2 mm)	Scheibe (1,2 mm)	Arandela (1,2 mm)	
	5	8A00 54319	1	Rosetta di rasamento (1,2 mm)	Washer (1,2 mm)	Rondelle (1,2 mm)	Scheibe (1,2 mm)	Arandela (1,2 mm)	
	6	8000 31772	1	Anello elastico	Splitring	Anneau ressort	Sprengring	Anillo elástico	
	7	8000 59693	1	Ingr. 3ª vel. e 4ª (Z=16,18)	Driven gear 3rd and 4th speed (Z=16,18)	Engr. conduit 3ème et 4ème (Z=16,18)	Zahnrad 3. u. 4. Gang (Z=16,18)	Engr. 3º y 4º velocidad (Z=16,18)	
	8	8000 63625	1	Ingr. 5ª vel. (Z=20)	Gear 5th speed (Z=20)	Engrimage 5ème (Z=20)	Zahnrad 5. Gang (Z=20)	Engranaje 5º velocidad (Z=20)	
	9	8000 25572	114	Rullino	Roller	Aiguille	Rolle	Rodillo	
	10	8000 27690	68	Rullino	Roller	Aiguille	Rolle	Rodillo	
	11	8000 63624	1	Albero secondario completo	Layshaft compl.	Arbre secondaire compl.	Vorgelegewelle kpl.	Eje secundario compl.	
	12	8000 62152	1	Albero secondario	Layshaft	Arbre secondaire	Vorgelegewelle	Eje secundario	
	13	8000 59694	1	Ingr. 2ª vel. (Z=14)	2nd speed gear (Z=14)	Engrimage 2ème (Z=14)	Zahnrad 2. Gang (Z=14)	Engr. 2º velocidad (Z=14)	
	14	8000 59697	1	Ingr. 4ª vel. (Z=25)	4th speed gear (Z=25)	Engrimage 4ème (Z=25)	Zahnrad 4. Gang (Z=25)	Engr. 4º velocidad (Z=25)	
	15	8000 59696	1	Ingr. 3ª vel. (Z=27)	3rd speed gear (Z=27)	Engrimage 3ème (Z=27)	Zahnrad 3. Gang (Z=27)	Engranaje 3º velocidad (Z=27)	
	16	8000 62153	1	Vite	Screw	Vis	Schraube	Tornillo	
	17	8000 62154	1	Rosetta piana	Washer	Rondelle	Scheibe	Arandela	
	18	8000 36888	3	Anello elastico	Splitring	Anneau ressort	Sprengring	Anillo elástico	
	19	8000 63628	1	Ingr. 6ª vel. (Z=19)	Gear 6th speed (Z=19)	Engrimage 6ème (Z=19)	Zahnrad 6. Gang (Z=19)	Engranaje 6º velocidad (Z=19)	
	20	8000 59699	1	Ingr. 1ª vel. (Z=28)	Gear 1st speed (Z=28)	Engrimage 1ère (Z=28)	Zahnrad 1. Gang (Z=28)	Engranaje 1º velocidad (Z=28)	
	21	8000 22373	1	Cuscinetto a rullini (ø20xø24x10 mm)	Needle bearing (ø20xø24x10 mm)	Roulement à aiguilles (ø20xø24x10 mm)	Nadelkäfig (ø20xø24x10 mm)	Cojinete de rodillos (ø20xø24x10 mm)	
	22	8000 63626	1	Ingr. 5ª vel. (Z=23)	Gear 5th speed (Z=23)	Engrimage 5ème (Z=23)	Zahnrad 5. Gang (Z=23)	Engranaje 5º velocidad (Z=23)	
	23	8000 64868	1	Distanziale	Spacer	Entretoise	Distanzstück	Separador	
	24	8000 42700	1	Anello OR	O-Ring	Bague OR	O-Ring	Anillo OR	
	25	8000 07989	1	Rosetta di rasamento (0,3 mm)	Washer (0,3 mm)	Rondelle (0,3 mm)	Scheibe (0,3 mm)	Arandela (0,3 mm)	
	25	8B00 07989	1	Rosetta di rasamento (0,5 mm)	Washer (0,5 mm)	Rondelle (0,5 mm)	Scheibe (0,5 mm)	Arandela (0,5 mm)	
	25	8D00 07989	1	Rosetta di rasamento (0,7 mm)	Washer (0,7 mm)	Rondelle (0,7 mm)	Scheibe (0,7 mm)	Arandela (0,7 mm)	
	25	8E00 07989	1	Rosetta di rasamento (0,8 mm)	Washer (0,8 mm)	Rondelle (0,8 mm)	Scheibe (0,8 mm)	Arandela (0,8 mm)	
	25	8F00 07989	1	Rosetta di rasamento (0,9mm)	Washer (0,9mm)	Rondelle (0,9mm)	Scheibe (0,9mm)	Arandela (0,9mm)	

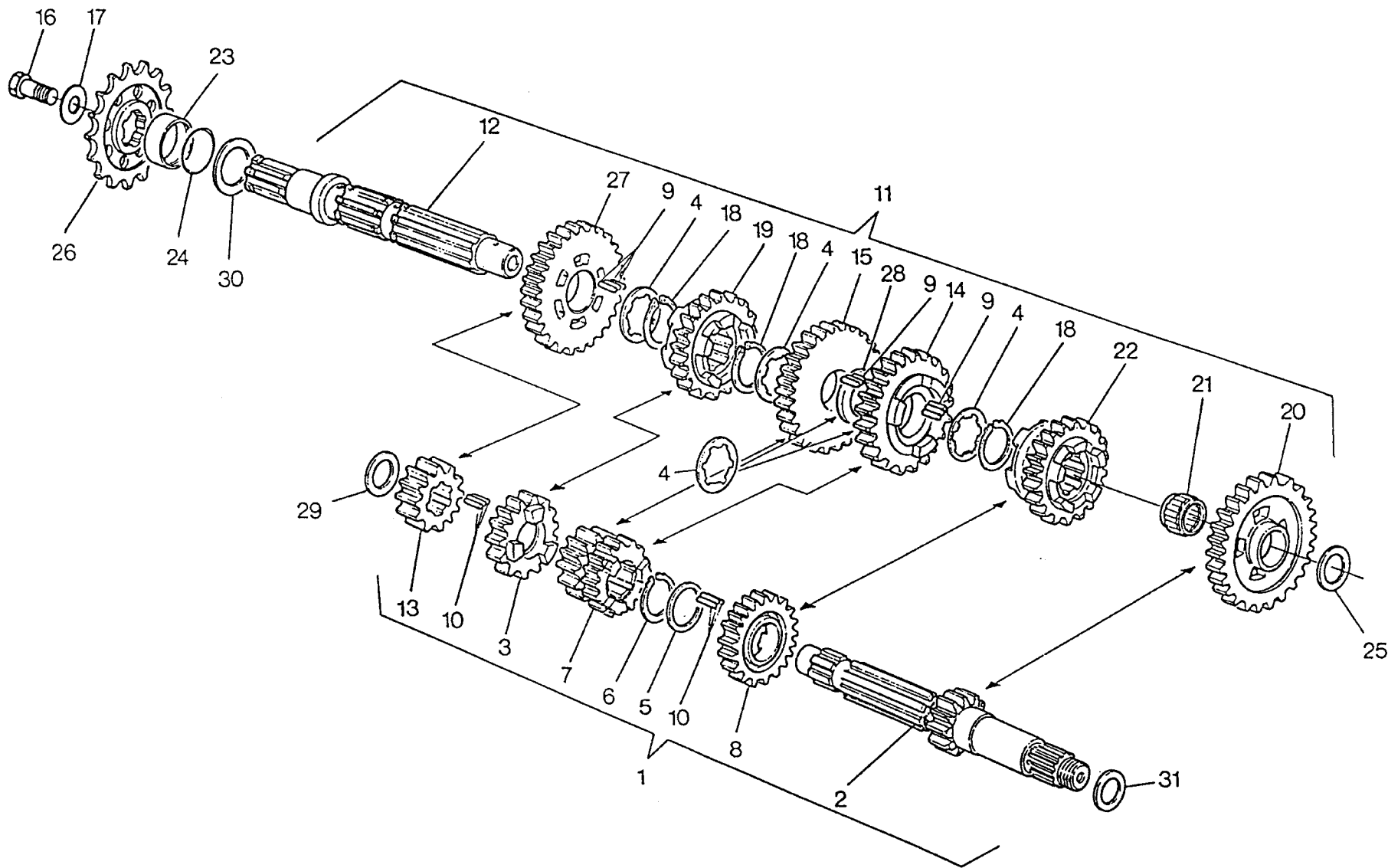



WR 360/2001

TAVOLA
DRAWING
TABLE
BILD
TABLA

9

CAMBIO - TRANSMISSION
BOITE DE VITESSE - WECHSELGETRIEBE
CAMBIO

Note Notes Notas	Pos. No. Index	N. Cod. Code No. Nr. Code Code Nr N. Cod.	Q.tà Q.ty Q.te M.ge C.ad	DENOMINAZIONE	NAME	DESIGNATION	BESHREIBUNG	DENOMINACION	Validità Validity Validité Gültig Validez
	25	8G00 07989	1	Rosetta di rasamento (1,0 mm)	Washer (1,0 mm)	Rondelle (1,0 mm)	Scheibe (1,0 mm)	Arandela (1,0 mm)	
	25	8H00 07989	1	Rosetta di rasamento (1,1 mm)	Washer (1,1 mm)	Rondelle (1,1 mm)	Scheibe (1,1 mm)	Arandela (1,1 mm)	
	25	8I00 07989	1	Rosetta di rasamento (1,2 mm)	Washer (1,2 mm)	Rondelle (1,2 mm)	Scheibe (1,2 mm)	Arandela (1,2 mm)	
S	26	8000 50620	1	Pignone (Z = 15)	Pinion (Z = 15)	Pignon (Z = 15)	Ritzel (Z = 15)	Piñón (Z = 15)	
R	26	8000 50619	1	Pignone (Z = 14)	Pinion (Z = 14)	Pignon (Z = 14)	Ritzel (Z = 14)	Piñón (Z = 14)	
	27	8000 59695	1	Ingr. 2ª vel. (Z=29)	2nd speed gear (Z=29)	Engranage 2ème (Z=29)	Zahnrad 2. Gang (Z=29)	Engr. 2º velocidad (Z=29)	
	28	8000 48168	1	Distanziale	Spacer	Entretoise	Distanzstück	Separador	
	29	8000 10904	1	Rosetta di rasamento (0,3 mm)	Washer (0,3 mm)	Rondelle (0,3 mm)	Scheibe (0,3 mm)	Arandela (0,3 mm)	
	29	8B00 10904	1	Rosetta di rasamento (0,5 mm)	Washer (0,5 mm)	Rondelle (0,5 mm)	Scheibe (0,5 mm)	Arandela (0,5 mm)	
	29	8D00 10904	1	Rosetta di rasamento (0,7 mm)	Washer (0,7 mm)	Rondelle (0,7 mm)	Scheibe (0,7 mm)	Arandela (0,7 mm)	
	29	8E00 10904	1	Rosetta di rasamento (0,8 mm)	Washer (0,8 mm)	Rondelle (0,8 mm)	Scheibe (0,8 mm)	Arandela (0,8 mm)	
	29	8F00 10904	1	Rosetta di rasamento (0,9 mm)	Washer (0,9 mm)	Rondelle (0,9 mm)	Scheibe (0,9 mm)	Arandela (0,9 mm)	
	29	8G00 10904	1	Rosetta di rasamento (1,0 mm)	Washer (1,0 mm)	Rondelle (1,0 mm)	Scheibe (1,0 mm)	Arandela (1,0 mm)	
	29	8H00 10904	1	Rosetta di rasamento (1,1 mm)	Washer (1,1 mm)	Rondelle (1,1 mm)	Scheibe (1,1 mm)	Arandela (1,1 mm)	
	29	8I00 10904	1	Rosetta di rasamento (1,2 mm)	Washer (1,2 mm)	Rondelle (1,2 mm)	Scheibe (1,2 mm)	Arandela (1,2 mm)	
	30	8C00 36022	1	Rosetta di rasamento (0,4 mm)	Washer (0,4 mm)	Rondelle (0,4 mm)	Scheibe (0,4 mm)	Arandela (0,4 mm)	
	30	8D00 36022	1	Rosetta di rasamento (0,5 mm)	Washer (0,5 mm)	Rondelle (0,5 mm)	Scheibe (0,5 mm)	Arandela (0,5 mm)	
	30	8F00 36022	1	Rosetta di rasamento (0,7 mm)	Washer (0,7 mm)	Rondelle (0,7 mm)	Scheibe (0,7 mm)	Arandela (0,7 mm)	
	30	8G00 36022	1	Rosetta di rasamento (0,8 mm)	Washer (0,8 mm)	Rondelle (0,8 mm)	Scheibe (0,8 mm)	Arandela (0,8 mm)	
	30	8H00 36022	1	Rosetta di rasamento (1,0 mm)	Washer (1,0 mm)	Rondelle (1,0 mm)	Scheibe (1,0 mm)	Arandela (1,0 mm)	
	30	8J00 36022	1	Rosetta di rasamento (1,1 mm)	Washer (1,1 mm)	Rondelle (1,1 mm)	Scheibe (1,1 mm)	Arandela (1,1 mm)	
	30	8K00 36022	1	Rosetta di rasamento (1,2 mm)	Washer (1,2 mm)	Rondelle (1,2 mm)	Scheibe (1,2 mm)	Arandela (1,2 mm)	
	31	8B00 36022	1	Rosetta di rasamento (0,3 mm)	Washer (0,3 mm)	Rondelle (0,3 mm)	Scheibe (0,3 mm)	Arandela (0,3 mm)	
	31	8C00 36022	1	Rosetta di rasamento (0,4 mm)	Washer (0,4 mm)	Rondelle (0,4 mm)	Scheibe (0,4 mm)	Arandela (0,4 mm)	
	31	8D00 36022	1	Rosetta di rasamento (0,5 mm)	Washer (0,5 mm)	Rondelle (0,5 mm)	Scheibe (0,5 mm)	Arandela (0,5 mm)	

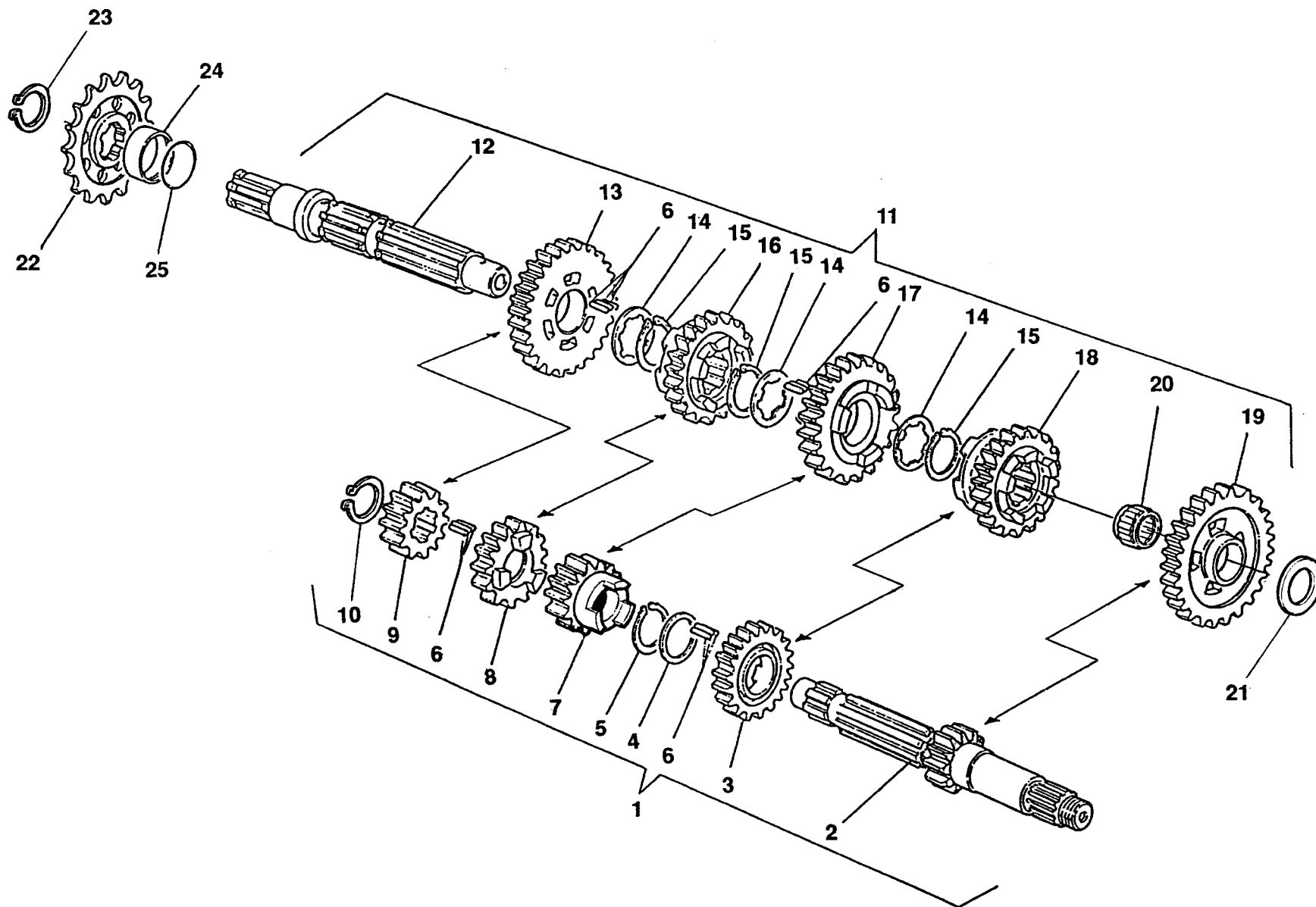

Note Notes Notas	Pos. No. Index Pos.	N. Cod. Code No. Nr. Code Code Nr N. Cod.	Q.tà Q.ty Q.te M.ge C.ad	DENOMINAZIONE	NAME	DESIGNATION	BESHREIBUNG	DENOMINACION	Validità Validity Validité Gültig Validez
W	1	8000 86899	1	Albero primario completo	Main shaft	Arbre primaire	Hauptwelle	Eje principal completo	
C	1	8000 86884	1	Albero primario completo	Main shaft	Arbre primaire	Hauptwelle	Eje principal completo	
	2	8000 86885	1	Albero primario (Z=14)	Main shaft (Z=14)	Arbre primaire (Z=14)	Hauptwelle (Z=14)	Eje primario (Z=14)	
W	3	8000 86992	1	Ingr. 5ª velocità (Z=24)	Gear 5th speed (Z=24)	Engranage 5ème (Z=24)	Zahnrad 5. Gang (Z=24)	Engranaje 5º velocidad (Z=24)	
C	3	8000 60944	1	Ingr. 5ª velocità (Z=19)	Gear 5th speed (Z=19)	Engranage 5ème (Z=19)	Zahnrad 5. Gang (Z=19)	Engranaje 5º velocidad (Z=19)	
	4	8A00 54319	1	Rosetta di rasamento (1,2 mm)	Washer (1,2 mm)	Rondelle (1,2 mm)	Scheibe (1,2 mm)	Arandela (1,2 mm)	
	5	8000 31772	1	Anello elastico	Splitring	Anneau ressort	Sprengring	Anillo elástico	
	6	8000 27690	144	Rullino	Roller	Aiguille	Rolle	Rodillo	
W	7	8000 86983	1	Ingr. 3ª velocità (Z=19)	Driven gear 3rd speed (Z=19)	Engr. conduit 3ème (Z=19)	Zahnrad 3. Gang (Z=19)	Engr. 3º velocidad (Z=19)	
C	7	8000 60947	1	Ingr. 3ª velocità (Z=16)	Driven gear 3rd speed (Z=16)	Engr. conduit 3ème (Z=16)	Zahnrad 3. Gang (Z=16)	Engr. 3º velocidad (Z=16)	
W	8	8000 86984	1	Ingr. 4ª vel. (Z=21)	4th speed gear (Z=21)	Engranage 4ème (Z=21)	Zahnrad 4. Gang (Z=21)	Engr. 4º velocidad (Z=21)	
C	8	8000 86990	1	Ingr. 4ª vel. (Z=19)	4th speed gear (Z=19)	Engranage 4ème (Z=19)	Zahnrad 4. Gang (Z=19)	Engr. 4º velocidad (Z=19)	
W	9	8000 86901	1	Ingr. 2ª vel. (Z=17)	2nd speed gear (Z=17)	Engranage 2ème (Z=17)	Zahnrad 2. Gang (Z=17)	Engr. 2º velocidad (Z=17)	
C	9	8000 86886	1	Ingr. 2ª vel. (Z=16)	2nd speed gear (Z=16)	Engranage 2ème (Z=16)	Zahnrad 2. Gang (Z=16)	Engr. 2º velocidad (Z=16)	
	10	66N0 21209	1	Anello elastico	Splitring	Anneau ressort	Sprengring	Anillo elástico	
W	11	8000 86985	1	Albero secondario completo	Layshaft compl.	Arbre secondaire compl.	Vorgelegewelle kpl.	Eje secundario compl.	
C	11	8000 86994	1	Albero secondario completo	Layshaft compl.	Arbre secondaire compl.	Vorgelegewelle kpl.	Eje secundario compl.	
	12	8000 86995	1	Albero secondario	Layshaft	Arbre secondaire	Vorgelegewelle	Eje secundario	
W	13	8000 86986	1	Ingr. 2ª vel. (Z=27)	2nd speed gear (Z=27)	Engranage 2ème (Z=27)	Zahnrad 2. Gang (Z=27)	Engr. 2º velocidad (Z=27)	
C	13	8000 82929	1	Ingr. 2ª vel. (Z=28)	2nd speed gear (Z=28)	Engranage 2ème (Z=28)	Zahnrad 2. Gang (Z=28)	Engr. 2º velocidad (Z=28)	
	14	8A00 36889	3	Rosetta di rasamento (1,2 mm)	Washer (1,2 mm)	Rondelle (1,2 mm)	Scheibe (1,2 mm)	Arandela (1,2 mm)	
	15	8000 36888	3	Anello elastico	Splitring	Anneau ressort	Sprengring	Anillo elástico	
W	16	8000 86987	1	Ingr. 4ª vel. (Z=22)	4th speed gear (Z=22)	Engranage 4ème (Z=22)	Zahnrad 4. Gang (Z=22)	Engr. 4º velocidad (Z=22)	
C	16	8000 86991	1	Ingr. 4ª vel. (Z=23)	4th speed gear (Z=23)	Engranage 4ème (Z=23)	Zahnrad 4. Gang (Z=23)	Engr. 4º velocidad (Z=23)	
W	17	8000 86988	1	Ingr. 3ª vel. (Z=24)	3rd speed gear (Z=24)	Engranage 3ème (Z=24)	Zahnrad 3. Gang (Z=24)	Engranaje 3º velocidad (Z=24)	
C	17	8000 60951	1	Ingr. 3ª vel. (Z=23)	3rd speed gear (Z=23)	Engranage 3ème (Z=23)	Zahnrad 3. Gang (Z=23)	Engranaje 3º velocidad (Z=23)	
W	18	8000 86993	1	Ingr. 5ª vel. (Z=20)	Gear 5th speed (Z=20)	Engranage 5ème (Z=20)	Zahnrad 5. Gang (Z=20)	Engranaje 5º velocidad (Z=20)	
C	18	8000 82931	1	Ingr. 5ª vel. (Z=20)	Gear 5th speed (Z=20)	Engranage 5ème (Z=20)	Zahnrad 5. Gang (Z=20)	Engranaje 5º velocidad (Z=20)	
	19	8000 82928	1	Ingr. 1ª vel. (Z=30)	Gear 1st speed (Z=30)	Engranage 1ère (Z=30)	Zahnrad 1. Gang (Z=30)	Engranaje 1º velocidad (Z=30)	
	20	8000 22373	1	Cuscinetto a rullini (ø20xø24x10 mm)	Needle bearing (ø20xø24x10 mm)	Roulement à aiguilles (ø20xø24x10 mm)	Nadelkäfig (ø20xø24x10 mm)	Cojinete de rodillos (ø20xø24x10 mm)	
	21	8E00 07989	1	Rosetta di rasamento (0,8 mm)	Washer (0,8 mm)	Rondelle (0,8 mm)	Scheibe (0,8 mm)	Arandela (0,8 mm)	

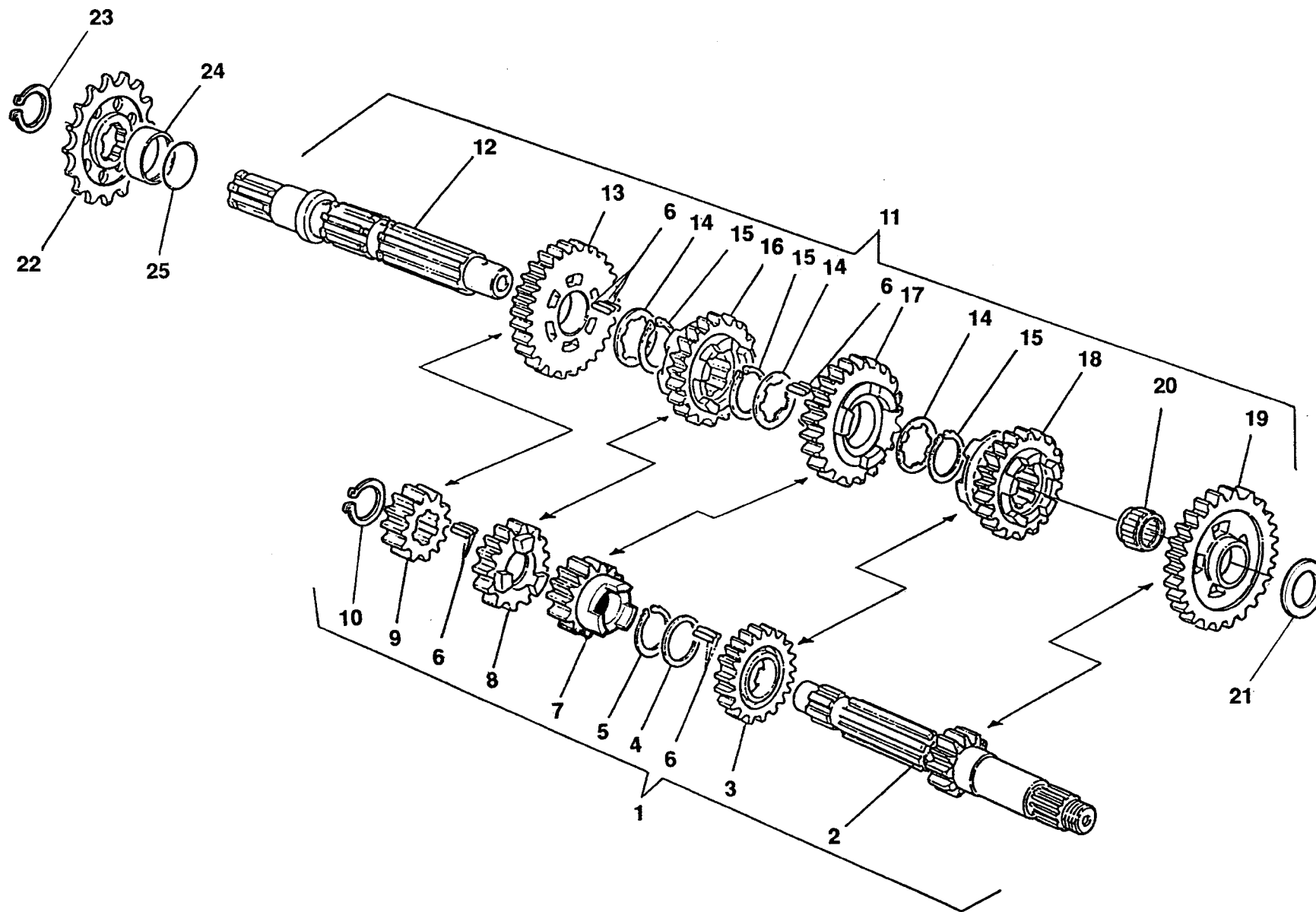

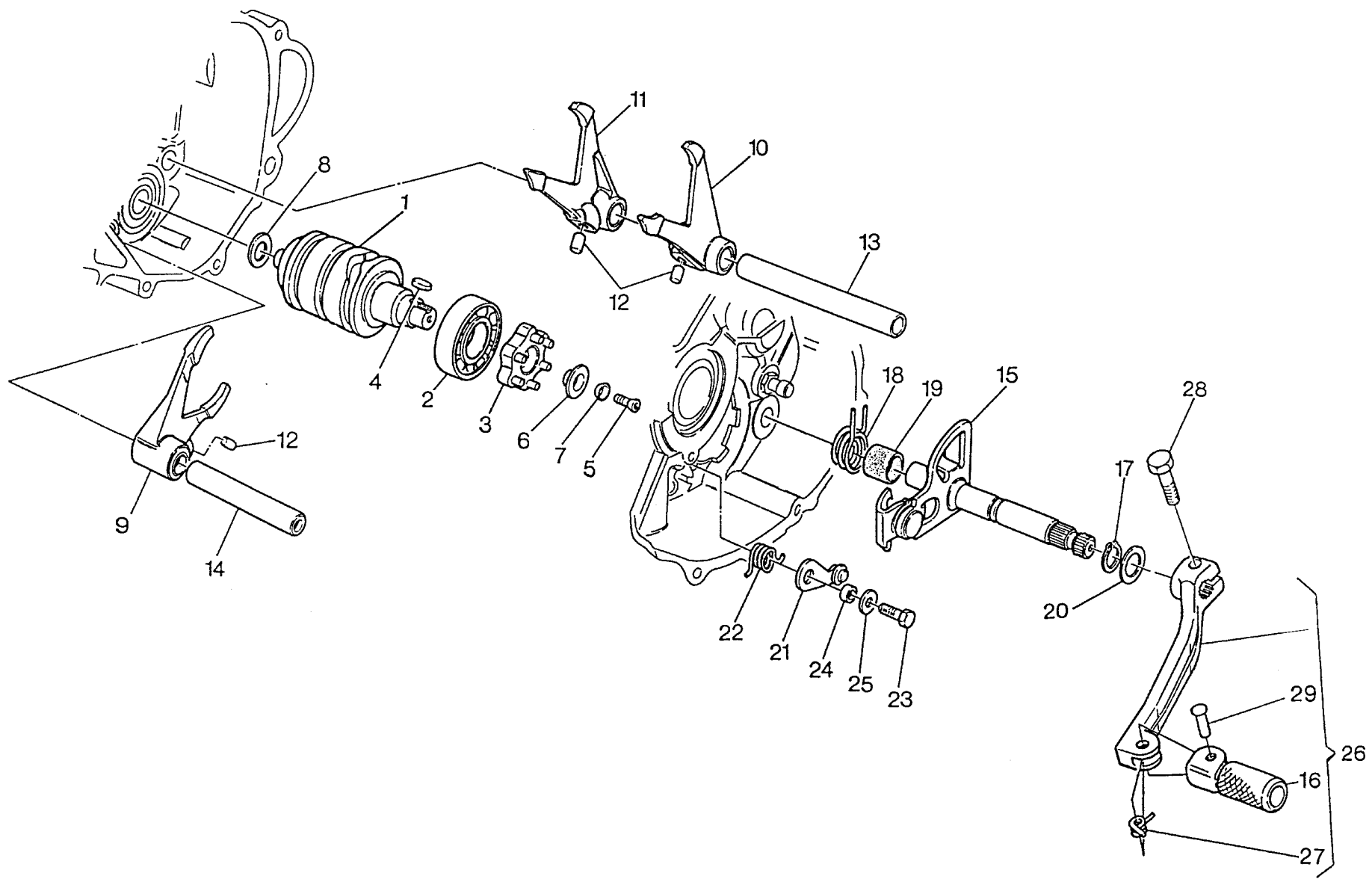



WR 360/2001

TAVOLA
DRAWING
TABLE
BILD
TABLA

10

COMANDO CAMBIO - SHIFTER
COMMANDE DE VITESSE - GANGSCHALTUNG
MANDO CAMBIO

Note Notes Notas	Pos. No. Index	N. Cod. Code No. Nr. Code Code Nr N. Cod.	Q.tà Q.ty Q.te M.ge C.ad	DENOMINAZIONE	NAME	DESIGNATION	BESHREIBUNG	DENOMINACION	Validità Validity Validité Gültig Validez
	1	8000 48134	1	Albero comando forcelle cambio	Driving shaft gearbox forks	Arbre comm. fourches trans.	Antriebswelle Schaltgabel	Eje mando horquilla cambio	
	2	8000 17040	1	Cuscinetto a sfere (ø20xø42x12 mm)	Ball bearing (ø20xø42x12 mm)	Roulement à billes (ø20xø42x12 mm)	Kugellager (ø20xø42x12 mm)	Cojinete de bolas (ø20xø42x12 mm)	
	3	8000 38706	1	Rocchetto	Sprocket	Rochet	Spule	Piñon	
	4	8000 38707	1	Linguetta	Key	Clé	Federkeil	Lengüeta	
	5	8000 47496	1	Vite	Screw	Vis	Schraube	Tornillo	
	6	8A00 38708	1	Rosetta	Washer	Rondelle	Scheibe	Arandela	
	7	8000 47160	1	Rosetta elastica	Spring washer	Rondelle élastique	Federscheibe	Arandela elástica	
	8	8000 01261	1	Rosetta di rasamento (0,2 mm)	Washer (0,2 mm)	Rondelle (0,2 mm)	Scheibe (0,2 mm)	Arandela (0,2 mm)	
	8	8A00 01261	1	Rosetta di rasamento (0,3 mm)	Washer (0,3 mm)	Rondelle (0,3 mm)	Scheibe (0,3 mm)	Arandela (0,3 mm)	
	8	8B00 01261	1	Rosetta di rasamento (0,5 mm)	Washer (0,5 mm)	Rondelle (0,5 mm)	Scheibe (0,5 mm)	Arandela (0,5 mm)	
	8	8C00 01261	1	Rosetta di rasamento (0,8 mm)	Washer (0,8 mm)	Rondelle (0,8 mm)	Scheibe (0,8 mm)	Arandela (0,8 mm)	
	8	8D00 01261	1	Rosetta di rasamento (1,0 mm)	Washer (1,0 mm)	Rondelle (1,0 mm)	Scheibe (1,0 mm)	Arandela (1,0 mm)	
	9	8000 48135	1	Forcella innesto 5 ^a - 6 ^a vel.	Fork	Fourche eng. vitesses	Schaltgabel	Horquilla marchas	
	10	8000 86980	1	Forcella innesto 1 ^a - 4 ^a vel.	Fork	Fourche eng. vitesses	Schaltgabel	Horquilla marchas	
	11	8000 48127	1	Forcella innesto 2 ^a - 3 ^a vel.	Fork	Fourche eng. vitesses	Schaltgabel	Horquilla marchas	
	12	8000 38728	3	Rullo	Roller	Aiguille	Rolle	Rodillo	
	13	8000 38711	1	Perno	Pin	Pivot	Bolzen	Perno	
	14	8000 38712	1	Perno	Pin	Pivot	Bolzen	Perno	
	15	8000 48128	1	Selettore	Selector	Selecteur	Waehler	Selector com.	
	16	8000 70215	1	Pedalino	Pedal	Pedale	Pedal	Pedal	
	17	66N0 21202	1	Anello elastico	Split ring	Anneau ressort	Sprengring	Anillo elástico	
	18	8000 46225	1	Molla	Spring	Ressort	Feder	Resorte	
	19	8000 61376	1	Distanziale	Spacer	Entretoise	Distanzstück	Separador	
	20	8D00 01261	1	Rosetta di rasamento (1,0 mm)	Washer (1,0 mm)	Rondelle (1,0 mm)	Scheibe (1,0 mm)	Arandela (1,0 mm)	
	21	8000 38721	1	Saltarello	Click	Cliquet	Strumhaken	Saltarelo	
	22	8000 57789	1	Molla	Spring	Ressort	Feder	Resorte	
	23	60N1 01079	1	Vite	Screw	Vis	Schraube	Tornillo	
	24	8000 42487	1	Distanziale	Spacer	Entretoise	Distanzstück	Separador	
	25	8000 02709	1	Rosetta	Washer	Rondelle	Scheibe	Arandela	
	26	8000 88969	1	Pedale comando cambio compl.	Crank lever assy	Levier compl.	Hebel kpl.	Pedal mando cambio compl.	
	27	8000 70216	1	Molla	Spring	Ressort	Feder	Remache	

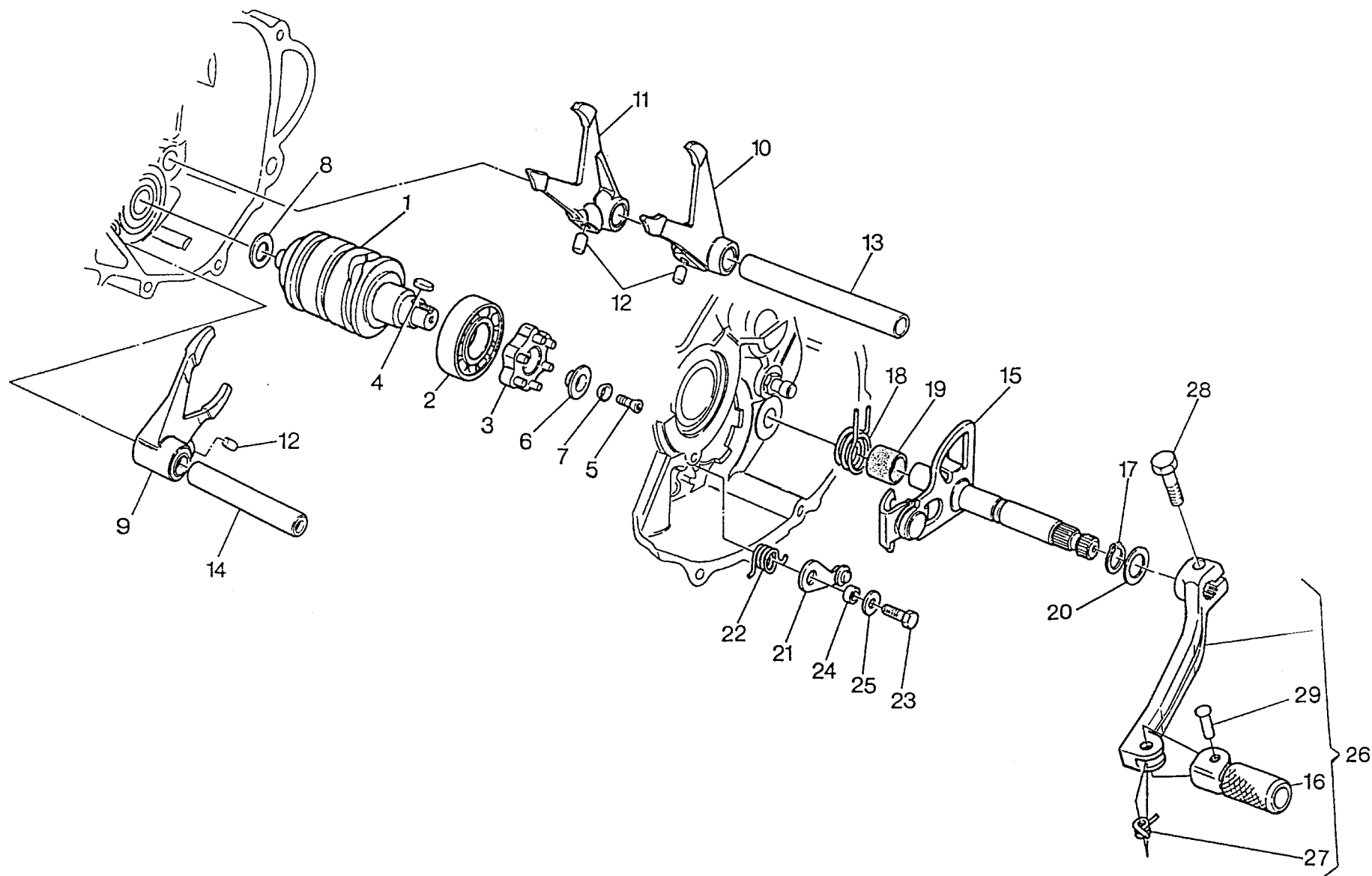

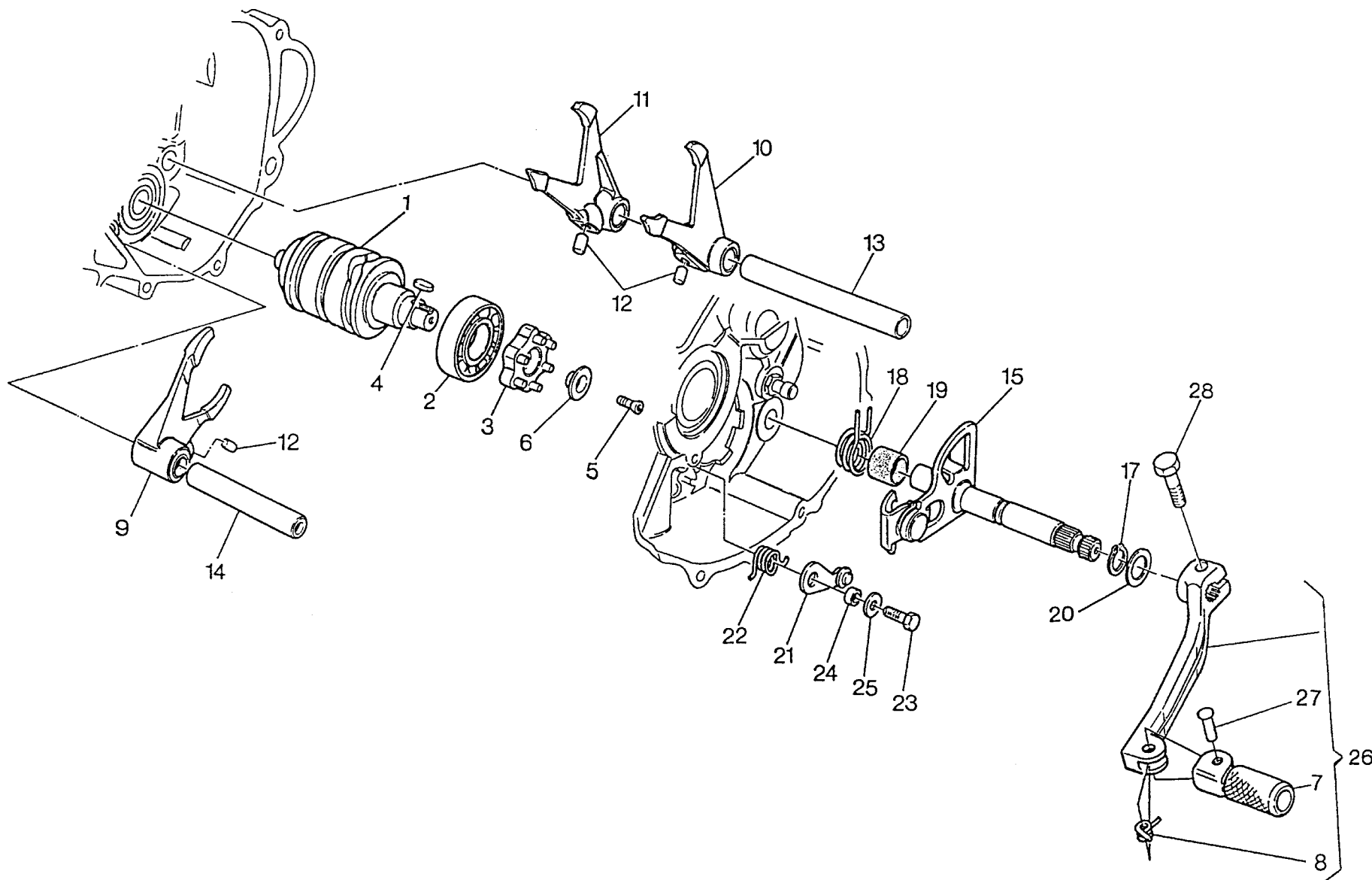

Note Notes Notas	Pos. No. Index	N. Cod. Code No. Nr. Code Code Nr N. Cod.	Q.tà Q.ty Q.te M.ge C.ad	DENOMINAZIONE	NAME	DESIGNATION	BESHREIBUNG	DENOMINACION	Validità Validity Validité Gültig Validez
	1	8000 48124	1	Albero comando forcelle cambio	Driving shaft gearbox forks	Arbre comm. fourches trans.	Antriebswelle Schaltgabel	Eje mando horquilla cambio	
	2	8000 17040	1	Cuscinetto a sfere (ø20xø42x12 mm)	Ball bearing (ø20xø42x12 mm)	Roulement à billes (ø20xø42x12 mm)	Kugellager (ø20xø42x12 mm)	Cojinete de bolas (ø20xø42x12 mm)	
	3	8000 38706	1	Rocchetto	Sprocket	Rochet	Spule	Piñon	
	4	8000 38707	1	Linguetta	Key	Clé	Federkeil	Lengüeta	
	5	8000 47496	1	Vite	Screw	Vis	Schraube	Tornillo	
	6	8A00 38708	1	Rosetta	Washer	Rondelle	Scheibe	Arandela	
	7	8000 70215	1	Pedalino	Pedal	Pedale	Pedal	Pedal	
	8	8000 70216	1	Molla	Spring	Ressort	Feder	Remache	
	9	8000 48125	1	Forcella	Fork	Fourche eng. vitesses	Schaltgabel	Horquilla marchas	
	10	8000 86980	1	Forcella	Fork	Fourche eng. vitesses	Schaltgabel	Horquilla marchas	
	11	8000 48127	1	Forcella	Fork	Fourche eng. vitesses	Schaltgabel	Horquilla marchas	
	12	8000 38728	3	Rullo	Roller	Aiguille	Rolle	Rodillo	
	13	8000 38711	1	Perno	Pin	Pivot	Bolzen	Perno	
	14	8000 38712	1	Perno	Pin	Pivot	Bolzen	Perno	
	15	8000 48128	1	Selettore	Selector	Selecteur	Waehler	Selector com.	
	17	66N0 21202	1	Anello elastico	Split ring	Anneau ressort	Sprengring	Anillo elástico	
	18	8000 46225	1	Molla	Spring	Ressort	Feder	Resorte	
	19	8000 46226	1	Distanziale	Spacer	Entretoise	Distanzstück	Separador	
	20	8D00 01261	1	Rosetta di rasamento (1,0 mm)	Washer (1,0 mm)	Rondelle (1,0 mm)	Scheibe (1,0 mm)	Arandela (1,0 mm)	
	21	8000 38721	1	Saltarello	Click	Cliquet	Strumhaken	Saltarello	
	22	8000 57789	1	Molla	Spring	Ressort	Feder	Resorte	
	23	60N1 01079	1	Vite	Screw	Vis	Schraube	Tornillo	
	24	8000 42487	1	Distanziale	Spacer	Entretoise	Distanzstück	Separador	
	25	8000 02709	1	Rosetta	Washer	Rondelle	Scheibe	Arandela	
	26	8000 88969	1	Pedale comando cambio compl.	Crank lever assy	Levier compl.	Hebel kpl.	Pedal mando cambio compl.	
	27	8000 70217	1	Ribattino	Rivet	Rivet	Niet	Remache	
	28	8000 62728	1	Vite	Screw	Vis	Schraube	Tornillo	

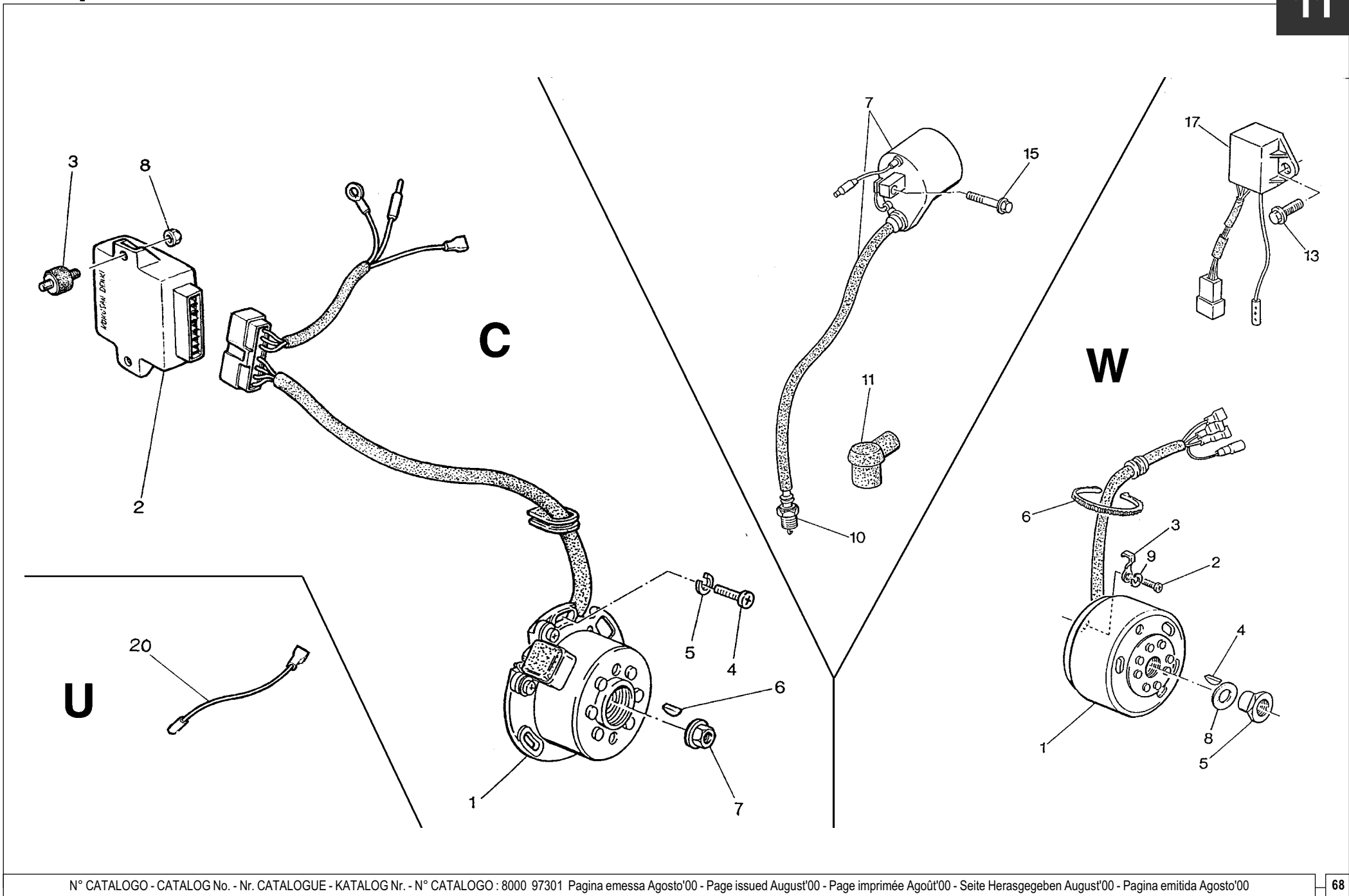



WR - CR 250/2001 ;
WR 360/2001

TAVOLA
DRAWING
TABLE
BILD
TABLA

11

PARTE ELETTRICA - ELECTRIC PART
PARTIE ELECTRIQUES - ELEKTRISCHETEILE
PARTE ELECTRICA

Note Notes Notas	Pos. No. Index	N. Cod. Code No. Nr. Code Code Nr N. Cod.	Q.tà Q.ty Q.te M.ge C.ad	DENOMINAZIONE	NAME	DESIGNATION	BESHREIBUNG	DENOMINACION	Validità Validity Validité Gültig Validez
W	1	8A00 75347	1	Alternatore completo (250)	Alternator compl. (250)	Alternateur compl. (250)	Lichtmaschine kpl. (250)	Alternador compl. (250)	
W	1	8000 75344	1	Alternatore completo (360)	Alternator compl. (360)	Alternateur compl. (360)	Lichtmaschine kpl. (360)	Alternador compl. (360)	
C	1	8000 91952	1	Alternatore completo	Alternator compl.	Alternateur compl.	Lichtmaschine kpl.	Alternador compl.	
W	2	8000 82496	2	Vite	Screw	Vis	Schraube	Tornillo	
C	2	8000 62727	2	Vite	Screw	Vis	Schraube	Tornillo	
	3	8000 49967	1	Piastrina	Plate	Plaquette	Plättchen	Placa	
	4	65N0 21002	1	Linguetta americana	Woodruff key	Clé woodruff	Federkeil	Lengüeta americana	
W	5	8000 73540	1	Dado	Nut	Ecrou	Mutter	Tuerca	
C	5	8000 42023	1	Dado	Nut	Ecrou	Mutter	Tuerca	
	6	8000 21811	4	Fascetta	Clamp	Collier	Schelle	Banda	
W	7	8000 75346	1	Bobina	Coil	Bobine	Zündspule	Bobina	
C	7	8000 72887	1	Bobina	Coil	Bobine	Zündspule	Bobina	
W	8	8000 73593	1	Rosetta	Washer	Rondelle	Scheibe	Arandela	
W	9	8000 38291	2	Rosetta elastica	Washer	Rondelle	Scheibe	Arandela	
C	9	62N1 15504	2	Rosetta elastica	Washer	Rondelle	Scheibe	Arandela	
W	10	8000 76016	1	Candela	Spark plug	Bougie	Zundkerze	Bujías	
WA	10	8000 70206	1	Candela	Spark plug	Bougie	Zundkerze	Bujías	
C	10	8B00 57446	1	Candela	Spark plug	Bougie	Zundkerze	Bujías	
	11	8000 75270	1	Pipetta schermata	Plug pipe	Pipette bougie	Kerzenstecker	Pipa bujía	
C	12	8000 90012	2	Supporto elastico	Elastic support	Suppport	Halterung	Soporte	
W	13	8000 62725	2	Vite	Screw	Vis	Schraube	Tornillo	
C	14	8000 44240	2	Dado	Nut	Ecrou	Mutter	Tuerca	
	15	8000 62727	2	Vite	Screw	Vis	Schraube	Tornillo	
W	17	8000 75343	1	Centralina elettronica (250)	Electronic device (250)	Dispositif électronique (250)	Zundelektronik (250)	Centralita electronica (250)	
W	17	8000 75345	1	Centralina elettronica (360)	Electronic device (360)	Dispositif électronique (360)	Zundelektronik (360)	Centralita electronica (360)	
C	17	8000 91953	1	Centralina elettronica	Electronic device	Dispositif électronique	Zundelektronik	Centralita electronica	
U	20	8000 80145	1	Cavo regolatore-bobina	Voltage rectifier-coil cable	Cable regulateur-bobine	Kabel Spannungregler Zundspule	Cable regulator-bobina	

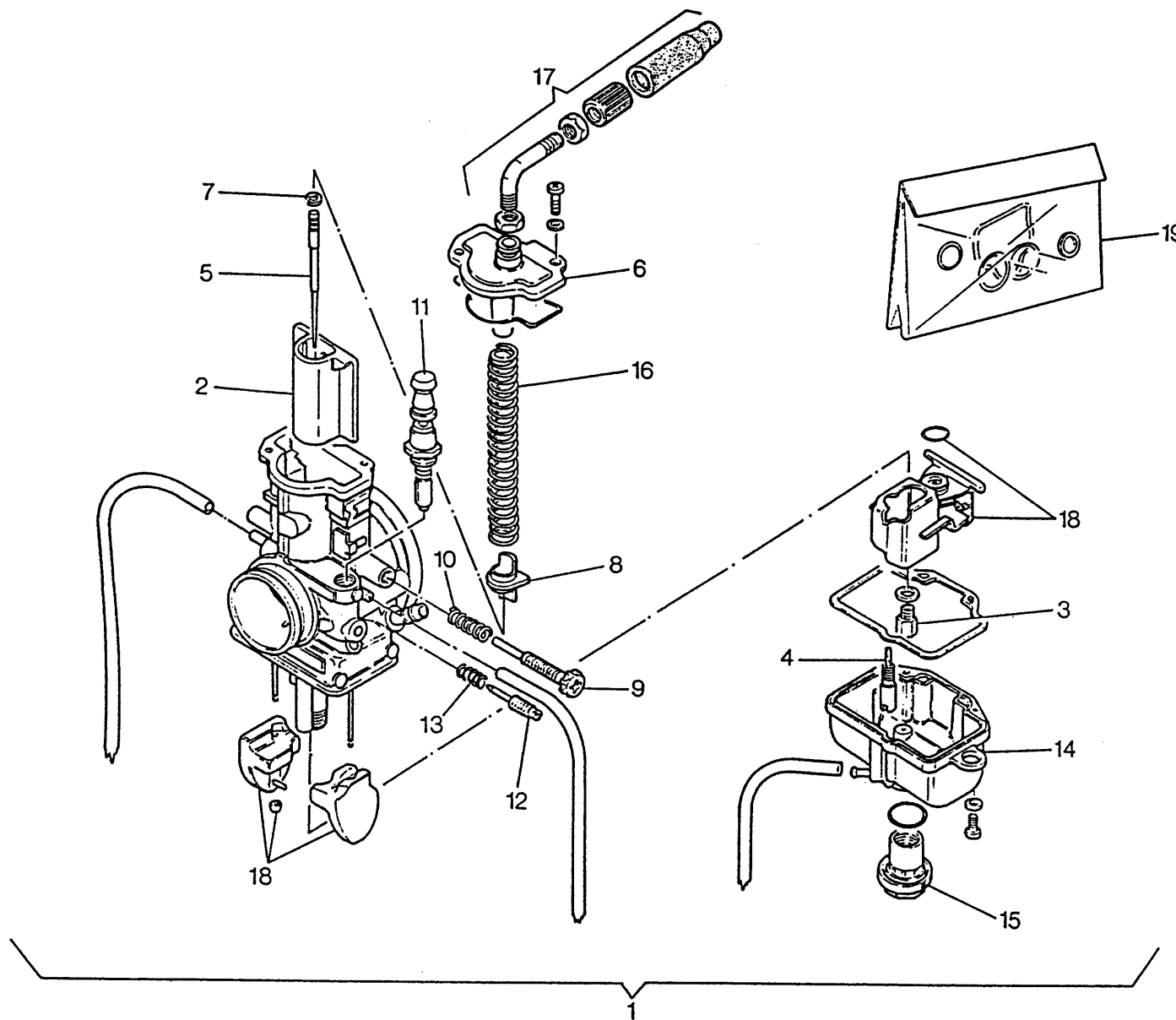



WR 360/2001

TAVOLA
DRAWING
TABLE
BILD
TABLA

12

CARBURATORE - CARBURETOR
CARBURATEUR - VERGASER
CARBURADOR

Note Notes Notes Marka Notas	Pos. No. N. Index Pos.	N. Cod. Code No. Nr. Code Code Nr N. Cod.	Q.tà Q.ty Q.te M.ge C.ad	DENOMINAZIONE	NAME	DESIGNATION	BESHREIBUNG	DENOMINACION	Validità Validity Validité Gültig Validez
	1	8000 73988	1	Assieme carburatore	Carburetor assy	Carburateur compl.	Vergaser kpl.	Carburador compl.	
	2	8D00 72312	1	Valvola gas (4,0)	Throttle valve (4,0)	Papillon de gaz (4,0)	Drosselklappe (4,0)	Válvula (4,0)	
DR	2	8B00 72312	1	Valvola gas da (3,0)	Throttle valve (3,0)	Papillon de gaz (3,0)	Drosselklappe (3,0)	Válvula (3,0)	
R	2	8C00 72312	1	Valvola gas da (3,5)	Throttle valve (3,5)	Papillon de gaz (3,5)	Drosselklappe (3,5)	Válvula (3,5)	
	3	8Z00 72310	1	Getto max. (430)	Main jet (430)	Gicleur principal (430)	Hauptdüse (430)	Chiclé máximo (430)	
D	3	8S00 72310	1	Getto max. (360)	Main jet (360)	Gicleur principal (360)	Hauptdüse (360)	Chiclé máximo (360)	
D	3	8T00 72310	1	Getto max. (370)	Main jet (370)	Gicleur principal (370)	Hauptdüse (370)	Chiclé máximo (370)	
D	3	8U00 72310	1	Getto max. (380)	Main jet (380)	Gicleur principal (380)	Hauptdüse (380)	Chiclé máximo (380)	
D	3	8V00 72310	1	Getto max. (390)	Main jet (390)	Gicleur principal (390)	Hauptdüse (390)	Chiclé máximo (390)	
D	3	8W00 72310	1	Getto max. (400)	Main jet (400)	Gicleur principal (400)	Hauptdüse (400)	Chiclé máximo (400)	
R	3	8X00 72310	1	Getto max. (410)	Main jet (410)	Gicleur principal (410)	Hauptdüse (410)	Chiclé máximo (410)	
R	3	8Y00 72310	1	Getto max. (420)	Main jet (420)	Gicleur principal (420)	Hauptdüse (420)	Chiclé máximo (420)	
R	3	8000 72311	1	Getto max. (440)	Main jet (440)	Gicleur principal (440)	Hauptdüse (440)	Chiclé máximo (440)	
R	3	8A00 72311	1	Getto max. (450)	Main jet (450)	Gicleur principal (450)	Hauptdüse (450)	Chiclé máximo (450)	
R	3	8B00 72311	1	Getto max. (460)	Main jet (460)	Gicleur principal (460)	Hauptdüse (460)	Chiclé máximo (460)	
R	3	8C00 72311	1	Getto max. (470)	Main jet (470)	Gicleur principal (470)	Hauptdüse (470)	Chiclé máximo (470)	
R	3	8D00 72311	1	Getto max. (480)	Main jet (480)	Gicleur principal (480)	Hauptdüse (480)	Chiclé máximo (480)	
R	3	8E00 72311	1	Getto max. (490)	Main jet (490)	Gicleur principal (490)	Hauptdüse (490)	Chiclé máximo (490)	
	4	8K00 72315	1	Getto minimo (40)	Idle jet (40)	Gicleur minimum (40)	Leerlaufdüse (40)	Chiclé mínimo (40)	
XD	4	8E00 72315	1	Getto minimo (27,5)	Idle jet (27,5)	Gicleur minimum (27,5)	Leerlaufdüse (27,5)	Chiclé mínimo (27,5)	
DR	4	8F00 72315	1	Getto minimo (30)	Idle jet (30)	Gicleur minimum (30)	Leerlaufdüse (30)	Chiclé mínimo (30)	
DR	4	8H00 72315	1	Getto minimo (35)	Idle jet (35)	Gicleur minimum (35)	Leerlaufdüse (35)	Chiclé mínimo (35)	
DR	4	8M00 72315	1	Getto minimo (45)	Idle jet (45)	Gicleur minimum (45)	Leerlaufdüse (45)	Chiclé mínimo (45)	
R	4	8P00 72315	1	Getto minimo (50)	Idle jet (50)	Gicleur minimum (50)	Leerlaufdüse (50)	Chiclé mínimo (50)	
	5	8E00 75556	1	Spillo conico (64)	Needle (64)	Pointeau conique (64)	Kon. Nadel (64)	Pasador cónico (64)	
D	5	8A00 75556	1	Spillo conico (60)	Needle (60)	Pointeau conique (60)	Kon. Nadel (60)	Pasador cónico (60)	
R	5	8C00 75556	1	Spillo conico (62)	Needle (62)	Pointeau conique (62)	Kon. Nadel (62)	Pasador cónico (62)	
R	5	8D00 75556	1	Spillo conico (63)	Needle (63)	Pointeau conique (63)	Kon. Nadel (63)	Pasador cónico (63)	
	6	8000 72333	1	Coperchio	Cover	Couvercle	Deckel	Tapa	
	7	8000 72323	1	Anello elastico	Splitring	Anneau ressort	Sprengring	Anillo elástico	
	8	8000 72324	1	Fermo molla	Spring	Ressort	Feder	Resorte	
	9	8000 72325	1	Vite aria	Screw	Vis	Schraube	Tornillo	

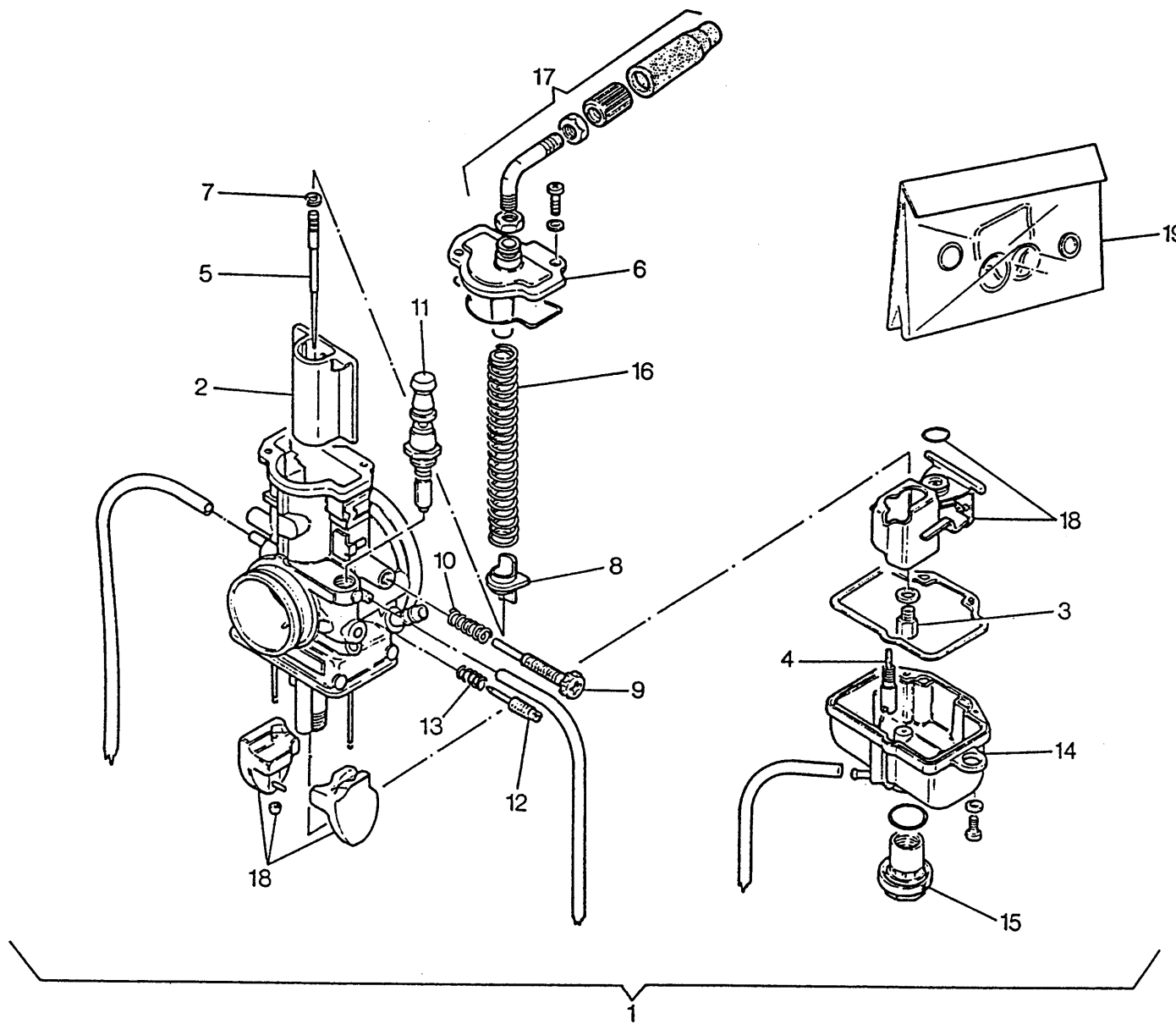

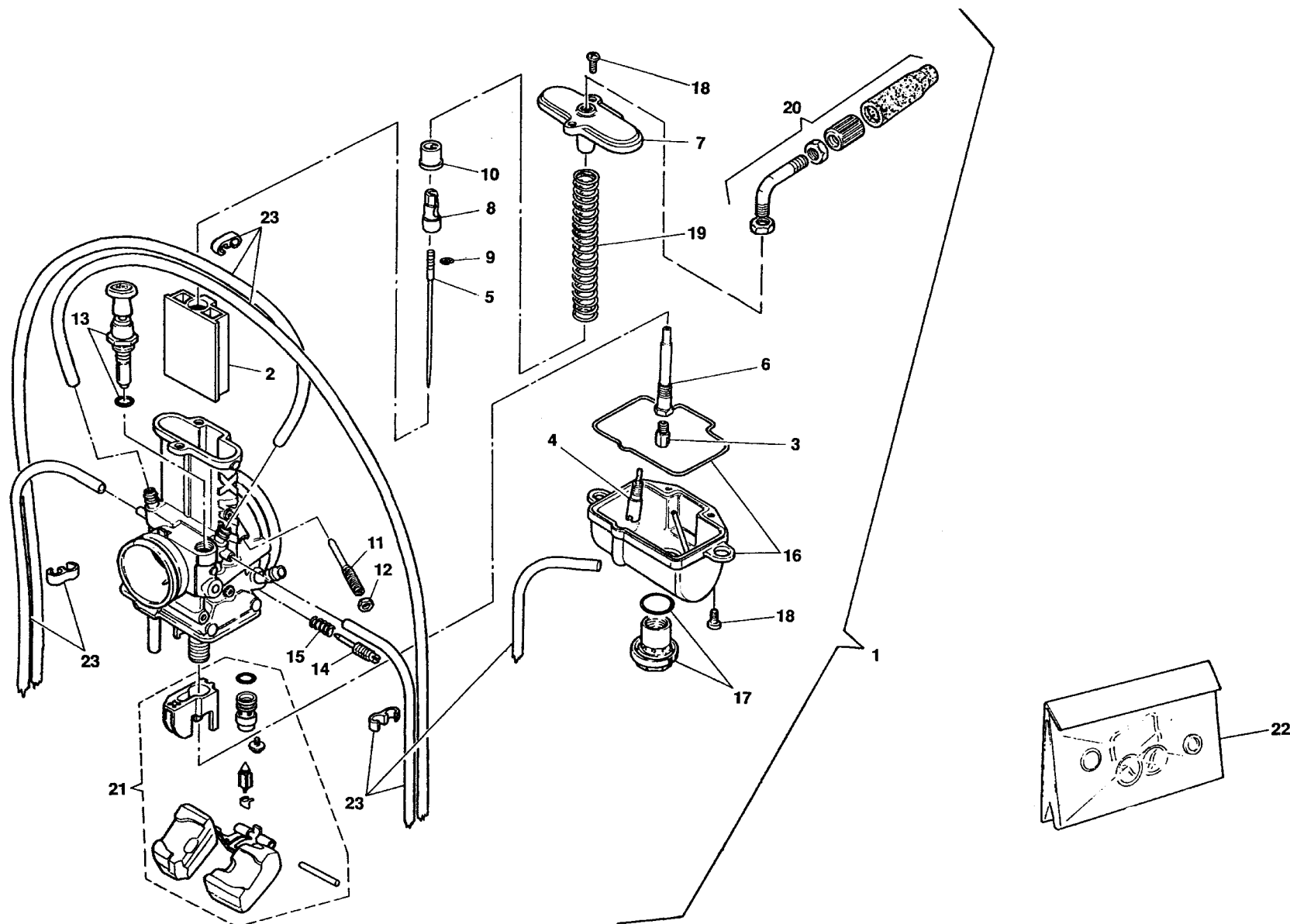

Note Notes Notas	Pos. No. Index	N. Cod. Code No. Nr. Code Code Nr N. Cod.	Q.tà Q.ty Q.te M.ge C.ad	DENOMINAZIONE	NAME	DESIGNATION	BESHREIBUNG	DENOMINACION	Validità Validity Validité Gültig Validez
	1	8000 86907	1	Assieme carburatore	Carburetor assy	Carburateur compl.	Vergaser kpl.	Carburador compl.	
	2	8D00 86918	1	Valvola gas da (4.0)	Throttle valve (4.0)	Papillon de gaz (4.0)	Drosselklappe (4.0)	Válvula (4.0)	
D	2	8000 86918	1	Valvola gas da (3.0)	Throttle valve (3.0)	Papillon de gaz (3.0)	Drosselklappe (3.0)	Válvula (3.0)	
R	2	8A00 86918	1	Valvola gas da (2.5)	Throttle valve (2.5)	Papillon de gaz (2.5)	Drosselklappe (2.5)	Válvula (2.5)	
R	2	8B00 86918	1	Valvola gas da (3.5)	Throttle valve (3.5)	Papillon de gaz (3.5)	Drosselklappe (3.5)	Válvula (3.5)	
	3	8W00 72310	1	Getto max. (400)	Main jet (400)	Gicleur principal (400)	Hauptdüse (400)	Chiclé máximo (400)	
DR	3	8T00 72310	1	Getto max. (370)	Main jet (370)	Gicleur principal (370)	Hauptdüse (370)	Chiclé máximo (370)	
DR	3	8U00 72310	1	Getto max. (380)	Main jet (380)	Gicleur principal (380)	Hauptdüse (380)	Chiclé máximo (380)	
DR	3	8V00 72310	1	Getto max. (390)	Main jet (390)	Gicleur principal (390)	Hauptdüse (390)	Chiclé máximo (390)	
DR	3	8X00 72310	1	Getto max. (410)	Main jet (410)	Gicleur principal (410)	Hauptdüse (410)	Chiclé máximo (410)	
R	3	8Y00 72310	1	Getto max. (420)	Main jet (420)	Gicleur principal (420)	Hauptdüse (420)	Chiclé máximo (420)	
R	3	8Z00 72310	1	Getto max. (430)	Main jet (430)	Gicleur principal (430)	Hauptdüse (430)	Chiclé máximo (430)	
	4	8000 86919	1	Getto minimo (35)	Idle jet (35)	Gicleur minimum (35)	Leerlaufdüse (35)	Chiclé mínimo (35)	
R	4	8A00 86919	1	Getto minimo (30)	Idle jet (30)	Gicleur minimum (30)	Leerlaufdüse (30)	Chiclé mínimo (30)	
DR	4	8B00 86919	1	Getto minimo (40)	Idle jet (40)	Gicleur minimum (40)	Leerlaufdüse (40)	Chiclé mínimo (40)	
D	4	8C00 86919	1	Getto minimo (45)	Idle jet (45)	Gicleur minimum (45)	Leerlaufdüse (45)	Chiclé mínimo (45)	
	5	8000 86920	1	Spillo conico (60-3a tacca)	Needle (60-3rd)	Pointeau conique (60-3ème)	Kon. Nadel (60-3.)	Pasador cónico (60-3°)	
D	5	8C00 86920	1	Spillo conico (58)	Needle (58)	Pointeau conique (58)	Kon. Nadel (58)	Pasador cónico (58)	
DR	5	8A00 86920	1	Spillo conico (59)	Needle (59)	Pointeau conique (59)	Kon. Nadel (59)	Pasador cónico (59)	
R	5	8B00 86920	1	Spillo conico (61)	Needle (61)	Pointeau conique (61)	Kon. Nadel (61)	Pasador cónico (61)	
	6	8000 86921	1	Polverizzatore	Fuel nozzle	Pulvérisateur	Einspritzdüse	Pulverizador	
	7	8000 86932	1	Coperchio	Cover	Couvercle	Deckel	Tapa	
	8	8000 86978	1	Fermo spillo e molla	Retainer	Arrêt	Klammer	Pasadør	
	9	8000 72323	1	Anello SEEGER	SEEGER ring	Anneau SEEGER	Ring SEEGER	Anillo SEEGER	
	10	8000 86925	1	Guida molla	Spring seat	Siège ressort	Feder sitzring	Alojamiento resorte	
	11	8000 86926	1	Vite aria	Screw	Vis	Schraube	Tornillo	
	12	8000 86927	1	Dado	Nut	Ecrou	Mutter	Tuerca	
	13	8000 72327	1	Dispositivo avviamento	Starting device	Dispositif de démarrage	Startvorrichtung	Dispositivo puesta en marcha	
	14	8000 72328	1	Vite minimo	Screw	Vis	Schraube	Tornillo	
	15	8000 72329	1	Molla	Spring	Ressort	Feder	Resorte	
	16	8000 86928	1	Vaschetta	Chamber	Cuvette	Becken	Cubeta	
	17	8000 72331	1	Dado	Nut	Ecrou	Mutter	Tuerca	

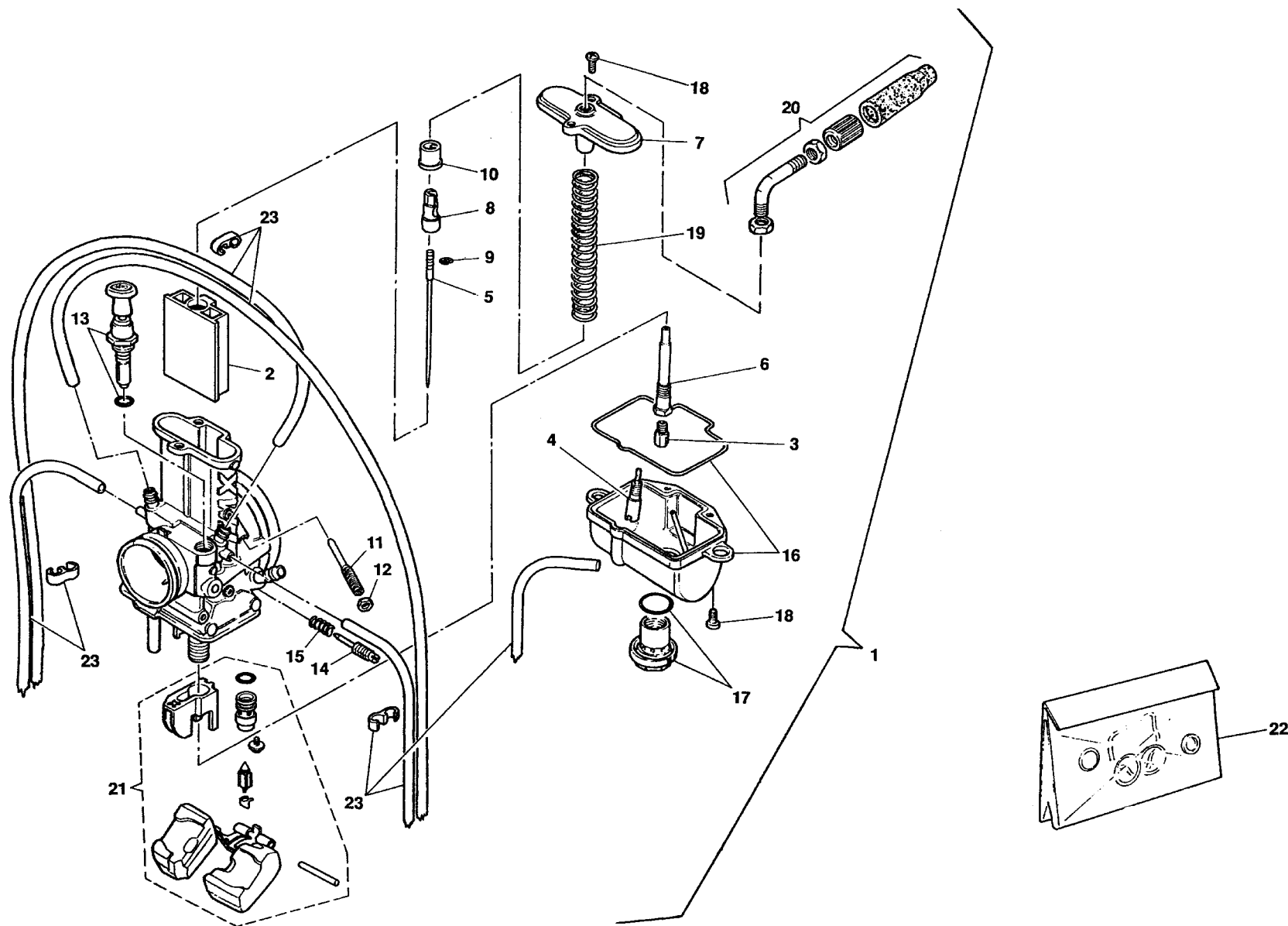

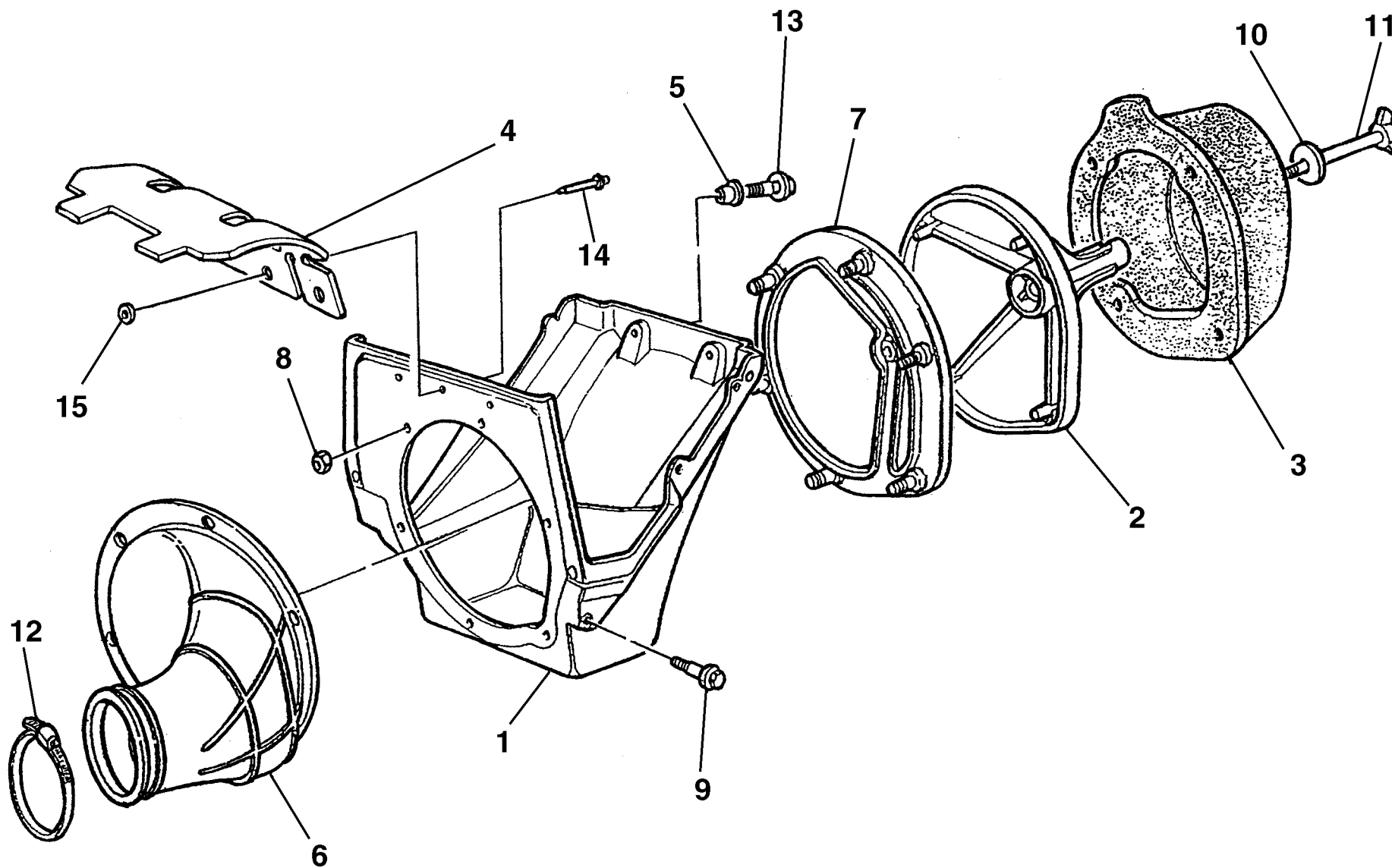



WR - CR 250/2001 ;
WR 360/2001

TAVOLA
DRAWING
TABLE
BILD
TABLA

13

FILTRO ARIA - AIR FILTER
FILTRE AIRE - AIRFILTER
FILTRO DE AIRE

Note Notes Notas	Pos. No. Index Pos.	N. Cod. Code No. Nr. Code Code Nr N. Cod.	Q.tà Q.ty Q.te M.ge C.ad	DENOMINAZIONE	NAME	DESIGNATION	BESHREIBUNG	DENOMINACION	Validità Validity Validité Gültig Validez
	1	80A0 91792	1	Scatola filtro	Air filter box	Boîte filtre	Filterkasten	Caja filtro aire	
	2	8000 69549	1	Gabbia filtro	Cleaner cage	Cage pour filtre	Filterkafig	Caja filtro	
	3	8000 72641	1	Filtro aria	Airfilter	Filtre à air	Luftfilter	Filtro aire	
	4	8000 95898	1	Protezione	Guard	Protection	Schutz	Protección	
	5	8000 69429	2	Bussola	Bushing	Duille	Buchse	Manguito	
	6	8A00 69546	1	Raccordo (360)	Union (360)	Raccord (360)	Anschluss (360)	Empalme (360)	
	6	8000 86888	1	Raccordo (250)	Union (250)	Raccord (250)	Anschluss (250)	Empalme (250)	
	7	8000 70024	1	Flangia	Flange	Bride	Flansch	Brida	
	8	8000 40718	6	Dado	Nut	Ecrou	Mutter	Tuerca	
	9	8000 62726	2	Vite	Screw	Vis	Schraube	Tornillo	
	10	62N1 15549	1	Rosetta piana	Washer	Rondelle	Scheibe	Arandela	
	11	8A00 37947	1	Vite	Screw	Vis	Schraube	Tornillo	
	12	8000 37906	1	Fascetta	Clamp	Collier	Schelle	Banda	
	13	8000 62728	2	Vite	Screw	Vis	Schraube	Tornillo	
	14	8000 33372	5	Rivetto	Rivet	Rivet	Niet	Remache	
	15	62N1 15547	5	Rosetta piana	Washer	Rondelle	Scheibe	Arandela	

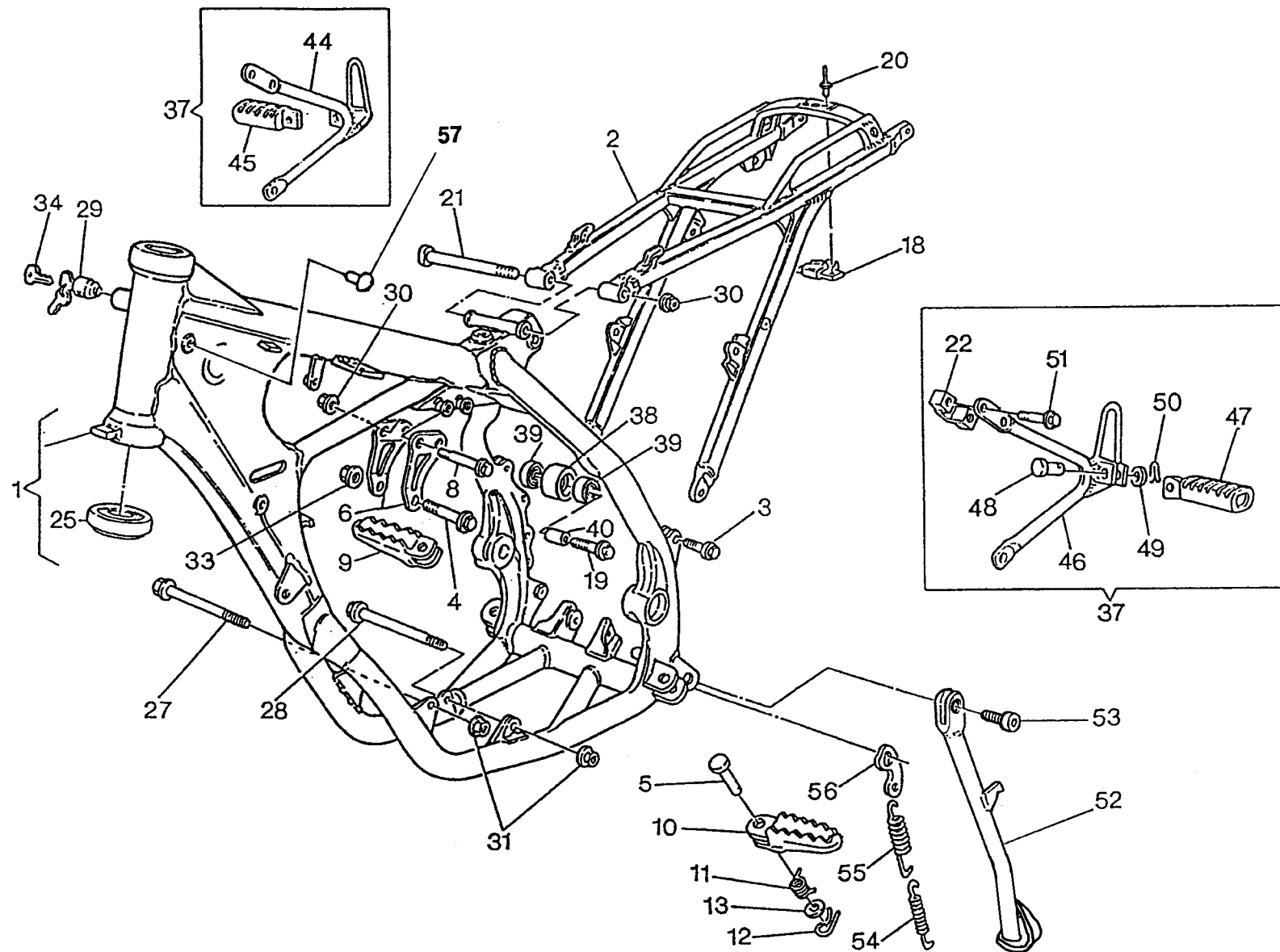



WR - CR 250/2001 ;
WR 360/2001

TAVOLA
DRAWING
TABLE
BILD
TABLA

14

TELAIO, PEDANE - FRAME, FOOT RESTS
CADRE, REPOSE PIEDS - RAHMEN, FUSSBRETT
BASTIDOR, REPOSAPIES

Note Notes Notas	Pos. No. Index	N. Cod. Code No. Nr. Code Code Nr N. Cod.	Q.tà Q.ty Q.te M.ge C.ad	DENOMINAZIONE	NAME	DESIGNATION	BESHREIBUNG	DENOMINACION	Validità Validity Validité Gültig Validez
W	1	8A00 97069	1	Parte anteriore compl.	Frame front side assy	Chassis av. compl. ()	Rahmen kpl.	Cuadro anterior compl.	
C	1	8A00 97029	1	Parte anteriore compl.	Frame front side assy	Chassis av. compl. ()	Rahmen kpl.	Cuadro anterior compl.	
U	1	8C00 97069	1	Parte anteriore compl.	Frame front side assy	Chassis av. compl. ()	Rahmen kpl.	Cuadro anterior compl.	
	2	8000 91535	1	Parte posteriore telaio	Rear frame side	Chassis arrière	Sattelbrücke	Cuadro posterior	
	3	8000 69056	2	Vite (M8x20 mm)	Screw (M8x20 mm)	Vis (M8x20 mm)	Schraube (M8x20 mm)	Tornillo (M8x20 mm)	
	4	8A00 62797	2	Vite (M10x50 mm)	Screw (M10x50 mm)	Vis (M10x50 mm)	Schraube (M10x50 mm)	Tornillo (M10x50 mm)	
	5	8000 73140	2	Perno	Pin	Pivot	Bolzen	Perno	
	6	8000 69434	2	Piastra	Plate	Plaque	Platte	Placa	
	8	8000 62795	2	Vite	Screw	Vis	Schraube	Tornillo	
	9	80A0 89953	1	Pedana destra	R.H. foot-rest	Repose-pieds D.	R. Fussraste	Pedal delnt. derech. compl.	
	10	80A0 89962	1	Pedana sinistra	L.H. foot-rest	Repose-pieds G.	L. Fussraste	Pedal delant. izrdo. compl.	
	11	8000 96908	1	Molla Dx	R.H. spring	Ressort D.	Feder Rechte	Resorte der.	
	11	8000 96907	1	Molla Sx	L.H. spring	Ressort G.	Feder Linke	Resorte iz.	
	12	64N1 20068	2	Copiglia	Splitpin	Goupille	Splint	Clavija	
	13	8A00 01815	2	Rosetta	Washer	Rondelle	Scheibe	Arandela	
	18	8000 69150	1	Piastrina	Plate	Plaquette	Plättchen	Placa	
	19	8000 62796	2	Vite (M8x40 mm)	Screw (M8x40 mm)	Vis (M8x40 mm)	Schraube (M8x40 mm)	Tornillo (M8x40 mm)	
	20	8000 33373	2	Rivetto	Rivet	Rivet	Niet	Remache	
	21	8000 69111	1	Vite (M8x134,5 mm)	Screw (M8x134,5 mm)	Vis (M8x134,5 mm)	Schraube (M8x134,5 mm)	Tornillo (M8x134,5 mm)	
XYD	22	8000 71091	2	Cavallotto	U-bolt	Cavalier	Bügelbolzen	Caballete	
WU	25	1513 07001	2	Cuscinetto a rulli conici (ø25xø50x17,5 mm)	Bearing (ø25xø50x17,5 mm)	Roulement à rouleaux coniques (ø25xø50x17,5 mm)	Lager (ø25xø50x17,5 mm)	Cojinete de rodillos cónicos (ø25xø50x17,5 mm)	
C	25	8000 87243	2	Cuscinetto a rulli conici (ø29xø48x17,5 mm)	Bearing (ø29xø48x17,5 mm)	Roulement à rouleaux coniques (ø29xø48x17,5 mm)	Lager (ø29xø48x17,5 mm)	Cojinete de rodillos cónicos (ø29xø48x17,5 mm)	
	27	8000 73458	1	Perno anteriore fissaggio motore (M8x100 mm)	Pin (M8x100 mm)	Pivot (M8x100 mm)	Bolzen (M8x100 mm)	Perno (M8x100 mm)	
	28	8A00 73458	1	Perno inferiore fissaggio motore (M8x115 mm)	Pin (M8x115 mm)	Pivot (M8x115 mm)	Bolzen (M8x115 mm)	Perno (M8x115 mm)	
XY	29	8000 43391	1	Serratura antifurto completa	Anti-left lock assy	Serrure anti-vol compl.	Sicherheitsschloss kpl.	Cerradura compl.	
	30	8000 43928	2	Dado	Nut	Ecrou	Mutter	Tuerca	
	31	8000 43928	2	Dado	Nut	Ecrou	Mutter	Tuerca	
	33	8000 42022	1	Dado	Nut	Ecrou	Mutter	Tuerca	

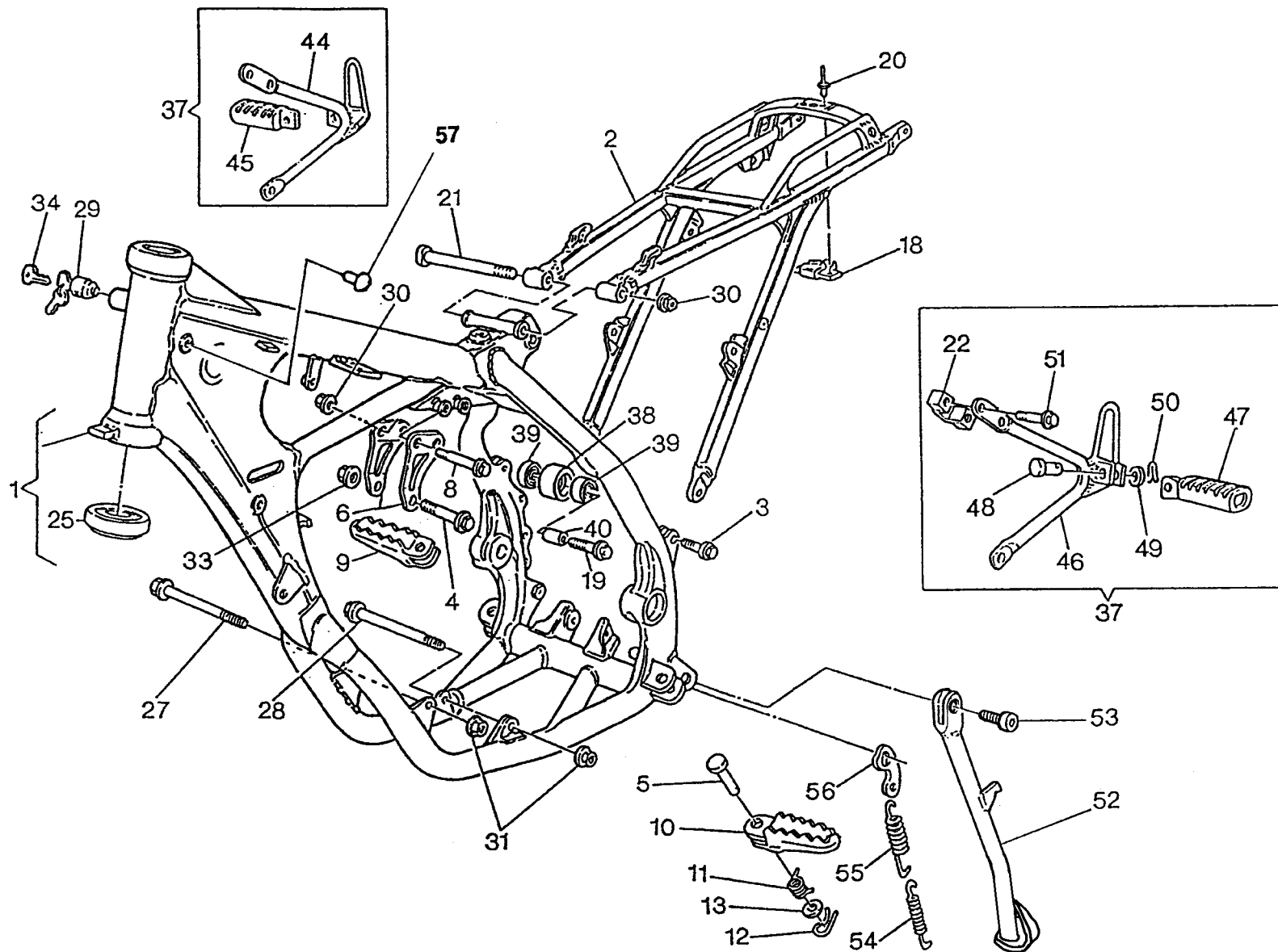



WR - CR 250/2001 ;
WR 360/2001

TAVOLA
DRAWING
TABLE
BILD
TABLA

14

TELAIO, PEDANE - FRAME, FOOT RESTS
CADRE, REPOSE PIEDS - RAHMEN, FUSSBRETT
BASTIDOR, REPOSAPIES

Note Notes Marka Notas	Pos. No. Index Pos.	N. Cod. Code No. Nr. Code Code Nr N. Cod.	Q.tà Q.ty Q.te M.ge C.ad	DENOMINAZIONE	NAME	DESIGNATION	BESHREIBUNG	DENOMINACION	Validità Validity Validité Gültig Validez
XY	34	8000 35531	1	Chiave grezza	Raw key	Clef primitive	Schlüssel	Llave	
XYD	37	8000 71086	2	Kit compl. poggiapiedi	Compl. footrest Kit	Appui-pied complet	kompl. Fussraster-Kit	Kit compl. apoyapiés	
	38	8000 59433	2	Rullo	Roller	Aiguille	Rolle	Rodillo	
	39	8000 63312	4	Cuscinetto (ø8xØ22x7 mm)	Bearing (ø8xØ22x7 mm)	Roulement (ø8xØ22x7 mm)	Kugellager (ø8xØ22x7 mm)	Cojinete (ø8xØ22x7 mm)	
	40	8000 59434	2	Distanziale	Spacer	Entretoise	Distanzstück	Separador	
XYD	44	8000 71088	1	Supporto Dx	R.H. support	Support D.	Halterung R.	Soporte der.	
XYD	45	8000 66652	1	Poggiapiedi passeggero Dx.	R.H. foot rest support	Support repose pied D.	R. Fussraster	Posapie der.	
XYD	46	8000 71087	1	Supporto Sx.	L.H. support	Support G.	Halterung L.	Soporte izq.	
XYD	47	8000 66651	1	Poggiapiedi passeggero Sx.	L.H. foot rest support	Support repose pied G.	L. Fussraster	Posapie izq.	
XYD	48	8000 41459	2	Perno	Pin	Pivot	Bolzen	Perno	
XYD	49	62N1 15504	2	Rosetta	Washer	Rondelle	Scheibe	Arandela	
XYD	50	64N1 20048	2	Copiglia	Split pin	Goupille	Splint	Clavija	
XYD	51	8000 69056	2	Vite (M8x20 mm)	Screw (M8x20 mm)	Vis (M8x20 mm)	Schraube (M8x20 mm)	Tornillo (M8x20 mm)	
XYD	51	8000 62732	2	Vite (M8x25 mm)	Screw (M8x25 mm)	Vis (M8x25 mm)	Schraube (M8x25 mm)	Tornillo (M8x25 mm)	
Y	52	8000 98040	1	Gamba laterale	Side stand	Bequille lat.	Seitenständer	Horquilla lateral	
UY	53	8A00 97977	1	Vite (M8x22 mm)	Screw (M8x22 mm)	Vis (M8x22 mm)	Schraube (M8x22 mm)	Tornillo (M8x22 mm)	
WY	53	8000 97976	1	Vite (M8x25 mm)	Screw (M8x25 mm)	Vis (M8x25 mm)	Schraube (M8x25 mm)	Tornillo (M8x25 mm)	
Y	54	8000 62676	1	Molla interna	Spring	Ressort	Feder	Resorte	
Y	55	8000 62675	1	Molla esterna	Spring	Ressort	Feder	Resorte	
Y	56	8000 84176	1	Piastrina	Plate	Plaque	Platte	Plaque	
C	57	8A00 75160	2	Rivetto	Rivet	Rivet	Niet	Remache	

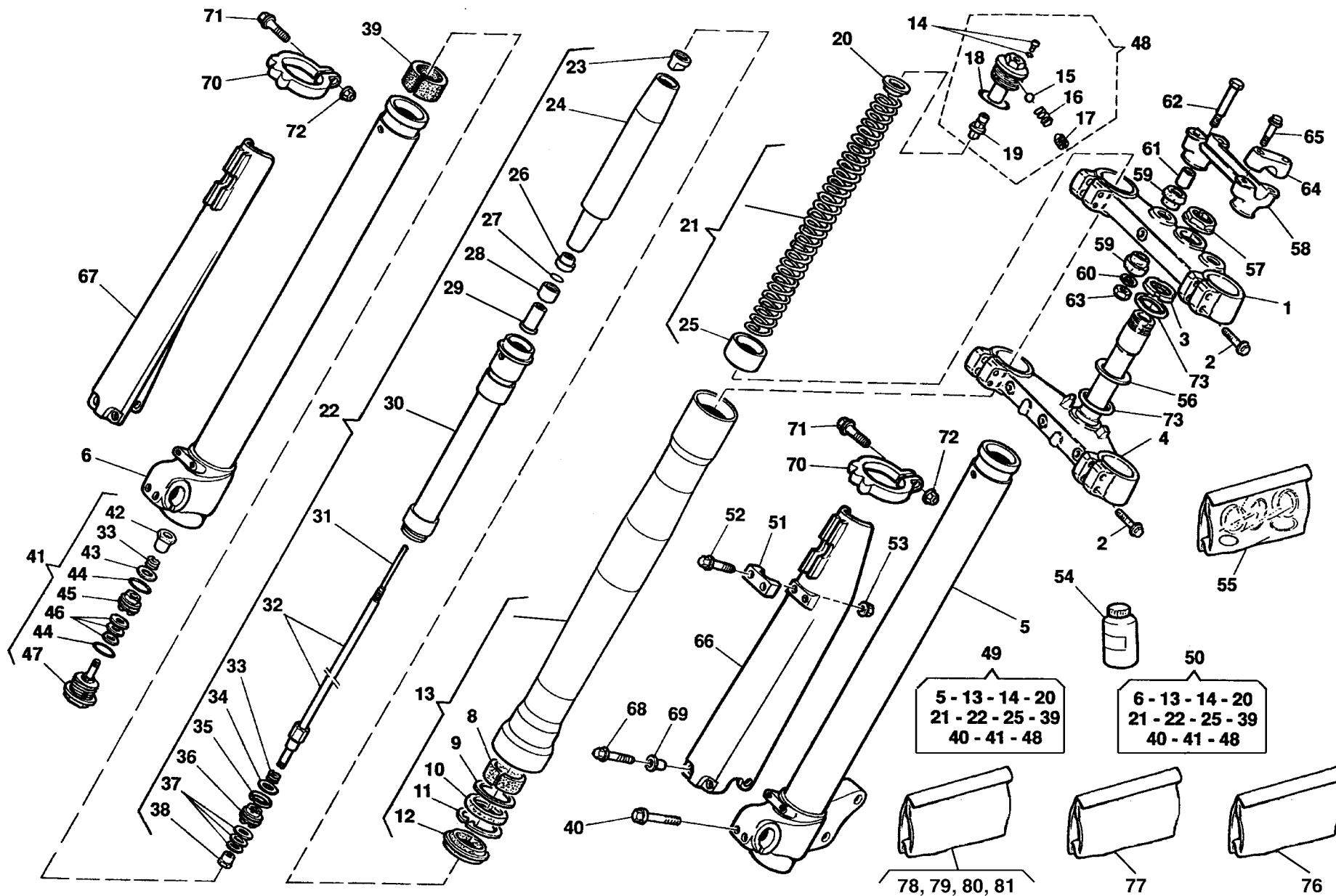



WR - CR 250/2001 ;
WR 360/2001

TAVOLA
DRAWING
TABLE
BILD
TABLA

15

SOSPENSIONE ANTERIORE - FRONT FORK ASSEMBLY
SUSPENSION AVANT - VORDERTELESKOPGABEL
SUSPENSION DELANTERA

Note Notes Markes Notas	Pos. No. Index Pos.	N. Cod. Code No. Nr. Code Code Nr N. Cod.	Q.tà Q.ty Q.te M.ge C.ad	DENOMINAZIONE	NAME	DESIGNATION	BESHREIBUNG	DENOMINACION	Validità Validity Validité Gültig Validez
W	1	8A00 96811	1	Testa di sterzo	Steering head	Tête direction	Lenkkopf	Cabezal de dirección	
C	1	8000 96811	1	Testa di sterzo	Steering head	Tête direction	Lenkkopf	Cabezal de dirección	
	2	8000 62796	8	Vite (M8x40 mm)	Screw (M8x40 mm)	Vis (M8x40 mm)	Schraube (M8x40 mm)	Tornillo (M8x40 mm)	
W	3	8000 83395	1	Ghiera registro cuscinetti	Ring nut	Embout	Nutmutter	Virol	
C	3	8A00 87717	1	Ghiera registro cuscinetti	Ring nut	Embout	Nutmutter	Virol	
W	4	8000 96897	1	Base di sterzo con perno	Steering crown with pin	Socle de direction avec pivot	Gabelbrücke mit Bolzen	Base de dirección con perno	
C	4	8000 96813	1	Base di sterzo con perno	Steering crown with pin	Socle de direction avec pivot	Gabelbrücke mit Bolzen	Base de dirección con perno	
W	5	8000 91507	1	Stelo Sx. compl.	L.H. slider assy	Montant G. compl.	Bein, Kpl. L.	Deslizable izrda. compl.	
C	5	8000 98787	1	Stelo Sx. compl.	L.H. slider assy	Montant G. compl.	Bein, Kpl. L.	Deslizable izrda. compl.	
W	6	8000 91506	1	Stelo Dx. compl.	R.H. slider assy	Montant D. compl.	Bein, Kpl. R.	Deslizable der. compl.	
C	6	8000 98786	1	Stelo Dx. compl.	R.H. slider assy	Montant D. compl.	Bein, Kpl. R.	Deslizable der. compl.	
N	8	(a), (b)	2	Bussola	Bushing	Douille	Buchse	Manguito	
N	9		2	Scodellino	Cup	Cuvette	Teller	Cubeta	
N	10	(a), (c)	2	Anello di tenuta	Seal ring	Bague de retenue	Dichtring	Anillo de retención	
N	11	(c)	2	Anello di fermo	Stop ring	Bague d'arrêt	Haltering	Anillo de retención	
N	12	(a), (c)	2	Raschiapolvere	Dust scraper	Racloir poudre	Pulverabschaber	Rascador de polvo	
	13	8000 91474	2	Portastelo completo	Pipe assy	Groupe tuyau compl.	Rohrgruppe Kpl	Grupo tubo compl.	
N	14		2	Vite	Screw	Vis	Schraube	Tornillo	
N	15		2	Sfera	Ball	Bille	Kugel	Esfera	
N	16		2	Molla per sfera	Spring	Ressort	Feder	Resorte	
N	17		2	Grano filettato	Dowel	Grain	Stift	Pasadòr	
N	18	(a)	2	Anello OR	O-Ring	Bague OR	O-Ring	Anillo OR	
	19	8000 91479	2	Gruppo registro	Adjusterset	Groupe réglage	Reglergruppe	Grupo regulaciòn	
	20	8000 77373	2	Scodellino	Cup	Cuvette	Teller	Cubeta	
W	21	8000 98791	1	Kit molla (k= 4,2 N/mm)	Spring (k= 4,2 N/mm)	Ressort (k= 4,2 N/mm)	Feder (k= 4,2 N/mm)	Resorte (k= 4,2 N/mm)	
C	21	8000 91610	1	Kit molla (k= 4,5 N/mm)	Spring (k= 4,5 N/mm)	Ressort (k= 4,5 N/mm)	Feder (k= 4,5 N/mm)	Resorte (k= 4,5 N/mm)	
W	22	8000 98552	2	Gruppo pompante compl.	Damping element compl.	Amortissement compl.	Schwingungsdämpfer Kpl.	Bombeadora compl.	
C	22	8000 98792	2	Gruppo pompante compl.	Damping element compl.	Amortissement compl.	Schwingungsdämpfer Kpl.	Bombeadora compl.	
N	23		2	Dado	Nut	Ecrou	Mutter	Tuerca	
N	24		2	Guidamolla	Spring guide	Guide ressort	Federführung	Guia resorte	
N	25		2	Tubetto	Pipe	Tuyau	Rohr	Tubo	
N	26		2	Dado	Nut	Ecrou	Mutter	Tuerca	

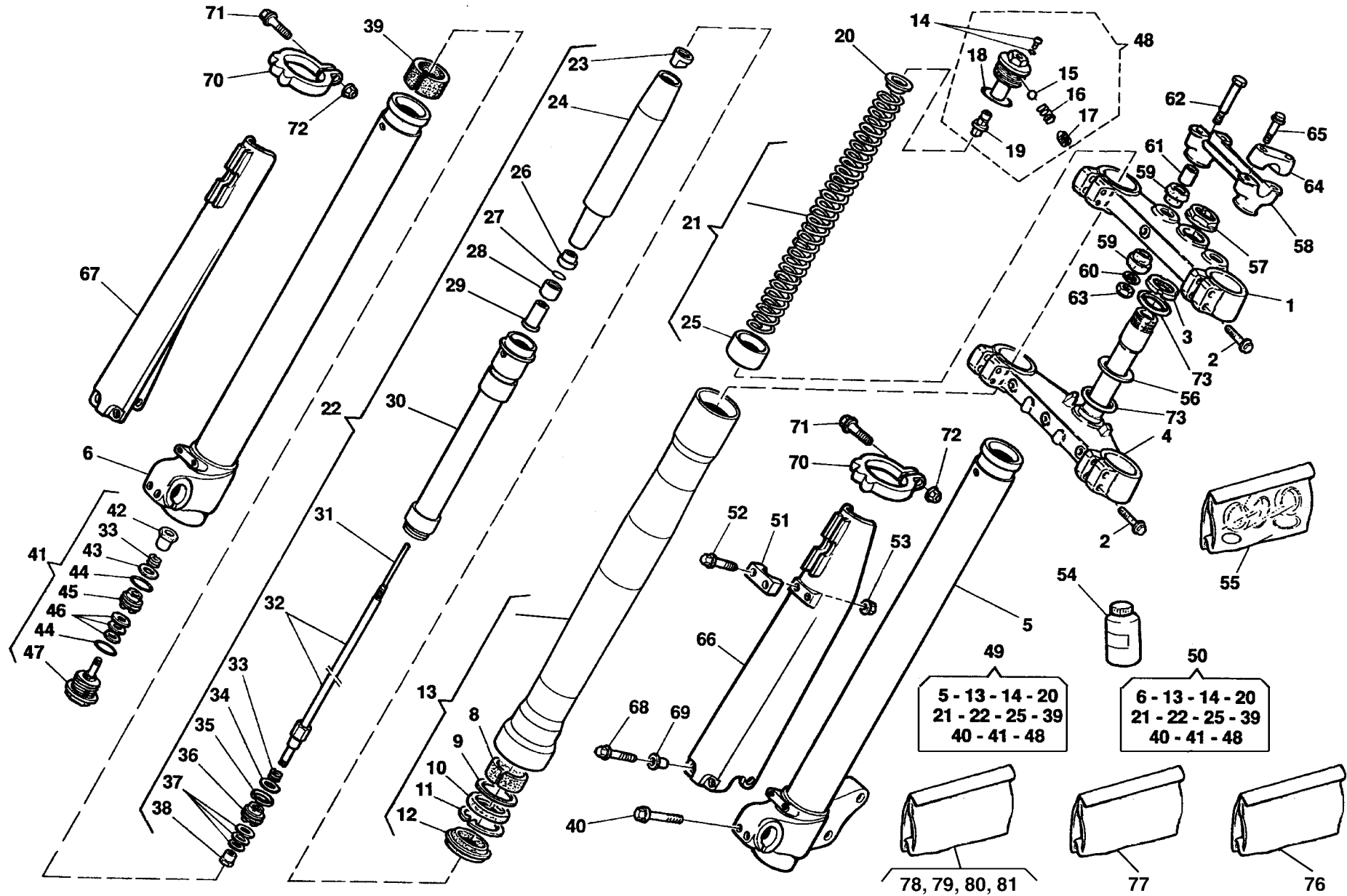

5 - 13 - 14 - 20
21 - 22 - 25 - 39
40 - 41 - 48

6 - 13 - 14 - 20
21 - 22 - 25 - 39
40 - 41 - 48

78, 79, 80, 81

77

76



WR - CR 250/2001 ;
WR 360/2001

TAVOLA
DRAWING
TABLE
BILD
TABLA

15

SOSPENSIONE ANTERIORE - FRONT FORK ASSEMBLY
SUSPENSION AVANT - VORDERTELESKOPGABEL
SUSPENSION DELANTERA

Note Notes Notas	Pos. No. Index	N. Cod. Code No. Nr. Code Code Nr N. Cod.	Q.tà Q.ty Q.te M.ge C.ad	DENOMINAZIONE	NAME	DESIGNATION	BESHREIBUNG	DENOMINACION	Validità Validity Validité Gültig Validez
N	27		2	Anello SEEGER	SEEGER ring	Anneau SEEGER	SEEGER Ring	Anillo SEEGER	
N	28		2	Tampone di fondo	Pad	Tampon	Stopfen	Tampòn	
N	29		2	Distanziale	Spacer	Entretoise	Distanzstück	Separadòr	
N	30		2	Custodia	Housung	Cage	Korb	Custodia	
N	31		2	Asta interna	Internal rod	Barre	Stange	Varilla	
N	32		2	Ass. asta	Rod assy	Barre compl.	Stange Kpl	Grupo varilla	
N	33		4	Molla	Spring	Ressort	Feder	Resorte	
N	34	(d)	2	Lamella	Plate	Lamelle	Plättchen	Laminilla	
N	35	(a)	2	Segmento	Circlip	Segment	Colbenring	Segmento	
N	36		2	Pistone estensione	R.H. piston	Piston D.	Kolbe R.	Pistón der.	
N	37	(d)	6	Lamella	Plate	Lamelle	Plättchen	Laminilla	
N	38		2	Dado	Nut	Ecrou	Mutter	Tueca	
N	39	(a), (b)	2	Bussola	Bushing	Douille	Buchse	Manguito	
	40	8000 62729	4	Vite (M6x25 mm)	Screw (M6x25 mm)	Vis (M6x25 mm)	Schraube (M6x25 mm)	Tornillo (M6x25 mm)	
W	41	8000 98806	2	Ass. valvola di fondo	Valve	Soupape	Ventil	Válvula	
C	41	8000 95260	2	Ass. valvola di fondo	Valve	Soupape	Ventil	Válvula	
N	42		2	Dado	Nut	Ecrou	Mutter	Tuerca	
N	43	(d)	2	Lamella	Plate	Lamelle	Plättchen	Laminilla	
N	44	(a)	2	Anello OR	O-Ring	Bague OR	O-Ring	Anillo OR	
N	45		2	Pistone compressione	Piston	Piston	Kolbe	Pistón	
N	46	(d)	6	Lamella	Plate	Lamelle	Plättchen	Laminilla	
N	47		2	Valvola	Valve	Soupape	Ventil	Valvula	
	48	8000 91480	2	Gruppo tappo	Plug assy	Groupe bouchon	Verschlussgruppe Kpl	Grupo tapón	
W	49	8000 97149	1	Gamba Sx. compl.	L.H. fork leg assy	Fourche complete G.	Telegabel Kpl. L.	Horquilla izrda. compl.	
C	49	8000 97035	1	Gamba Sx. compl.	L.H. fork leg assy	Fourche complete G.	Telegabel Kpl. L.	Horquilla izrda. compl.	
W	50	8000 97148	1	Gamba Dx. compl.	R.H. fork leg assy	Fourche complete D.	Telegabel Kpl. R.	Horquilla derech. compl.	
C	50	8000 97034	1	Gamba Dx. compl.	R.H. fork leg assy	Fourche complete D.	Telegabel Kpl. R.	Horquilla derech. compl.	
	51	80C0 69981	1	Piastrina	Plate	Plaquette	Plättchen	Placa	
	52	8A00 67997	2	Vite	Screw	Vis	Schraube	Tornillo	
	53	8000 61355	2	Dado	Nut	Ecrou	Mutter	Tueca	
R	54	8000 80260	1	Olio forcella	Front fork oil	Huile fourche avant	Öl für die Vordergabel	Aceite horquilladelantera	
	55	8000 91519	1	Gruppo guarnizioni	Gasket set	Groupe garnitures	Dichtungssatz	Grupo juntas	

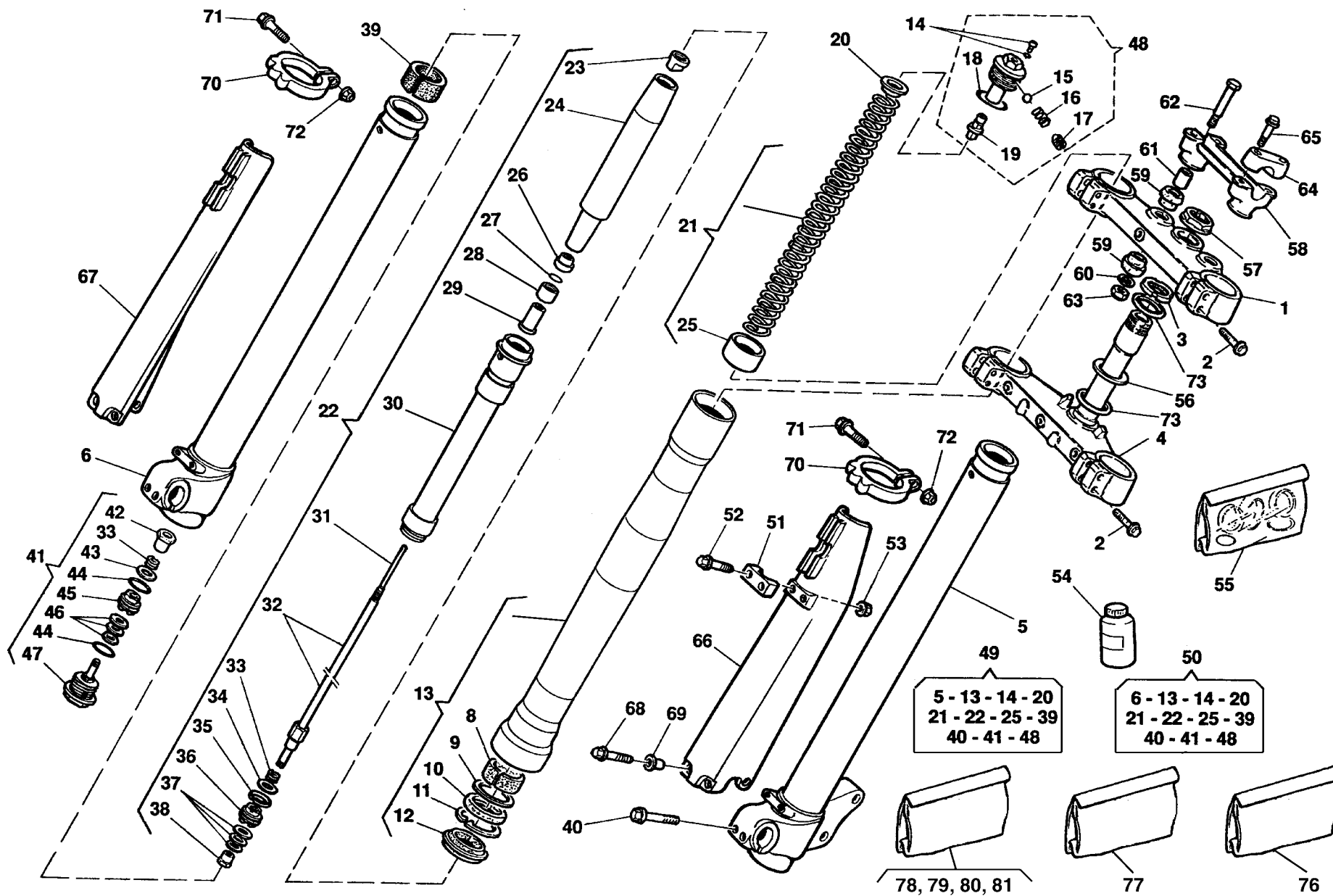



WR - CR 250/2001 ;
WR 360/2001

TAVOLA
DRAWING
TABLE
BILD
TABLA

15

SOSPENSIONE ANTERIORE - FRONT FORK ASSEMBLY
SUSPENSION AVANT - VORDERTELESKOPGABEL
SUSPENSION DELANTERA

Note Notes Notas	Pos. No. Index Pos.	N. Cod. Code No. Nr. Code Code Nr N. Cod.	Q.tà Q.ty Q.te M.ge C.ad	DENOMINAZIONE	NAME	DESIGNATION	BESHREIBUNG	DENOMINACION	Validità Validity Validité Gültig Validez
W	56	8A00 65503	2	Rosetta piana	Washer	Rondelle	Scheibe	Arandela	
C	56	8000 87736	1	Rosetta piana	Washer	Rondelle	Scheibe	Arandela	
W	57	8000 69315	1	Dado	Nut	Ecrou	Mutter	Tuerca	
C	57	8A00 69315	1	Dado	Nut	Ecrou	Mutter	Tuerca	
	58	8000 73141	1	Mozzetto inferiore	Hub	Moyeau	Radnabe	Cbo	
	59	8000 60233	4	Gommino	Rubber pad	Pièce caoutchouc	Gummstück	Junta de goma	
	60	8000 60234	2	Rosetta piana	Washer	Rondelle	Scheibe	Arandela	
	61	8000 53155	2	Distanziale	Spacer	Entretoise	Distanzstück	Separador	
	62	60N1 01219	2	Vite (M10x65 mm)	Screw(M10x65 mm)	Vis(M10x65 mm)	Schraube(M10x65 mm)	Tornillo(M10x65 mm)	
	63	8000 61314	2	Dado	Nut	Ecrou	Mutter	Tuerca	
	64	8000 68516	2	Mozzetto superiore	Hub	Moyeau	Radnabe	Cubo	
	65	8000 62733	4	Vite (M8x35 mm)	Screw (M8x35 mm)	Vis (M8x35 mm)	Schraube (M8x35 mm)	Tornillo (M8x35 mm)	
	66	80C0 69337	1	Protezione steli Sx.	Guard L.H.	Protection D.	Schutz L.	Protección izq.	
	67	80C0 69338	1	Protezione steli Dx.	Guard R.H.	Protection G.	Schutz R.	Protección der.	
	68	8000 67997	6	Vite	Screw	Vis	Schraube	Tornillo	
	69	8000 69282	6	Bussola	Bush	Douille	Buchse	Manguito	
	70	8000 93283	2	Anello	Ring	Bague	Ring	Anilo	
	71	8B00 66525	2	Vite	Screw	Vis	Schraube	Tornillo	
	72	8000 56443	2	Dado	Nut	Ecrou	Mutter	Tuerca	
C	73	8000 87745	2	Guarnizione di tenuta	Gasket	Garniture	Dichtung	Guarnición	
	76	8000 97750	1	Kit boccole	Bush kit	Kit douille	Buchsekit	Kitmanguito	
	77	8000 97749	1	Kit anelli di tenuta	Seal ring kit	Kit bague de retenue	Dichtringkit	Kit anillo de retención	
	78	8000 98782	1	Kit lamelle (0,1 mm)	Plate kit (0,1 mm)	Kit lamelle (0,1 mm)	Plättchenkit (0,1 mm)	Kit Laminilla (0,1 mm)	
	79	8000 98783	1	Kit lamelle (0,2 mm)	Plate kit (0,2 mm)	Kit lamelle (0,2 mm)	Plättchenkit (0,2 mm)	Kit Laminilla (0,2 mm)	
	80	8000 98784	1	Kit lamelle (0,3 mm)	Plate kit (0,3 mm)	Kit lamelle (0,3 mm)	Plättchenkit (0,3 mm)	Kit Laminilla (0,3 mm)	
	81	8000 98785	1	Kit lamelle (0,4 mm)	Plate kit (0,4 mm)	Kit lamelle (0,4 mm)	Plättchenkit (0,4 mm)	Kit Laminilla (0,4 mm)	
a				Forniti anche in gruppo pos. 55	Supplied in bag ref. N° 55	Son fournies en unités pos. 55	Sind im Umschlag Bez. Nr 55	Provisto en grupo pos. 55	
b				Forniti anche in gruppo pos. 76	Supplied in bag ref. N° 76	Son fournies en unités pos. 76	Sind im Umschlag Bez. Nr 76	Provisto en grupo pos. 76	
c				Forniti anche in gruppo pos. 77	Supplied in bag ref. N° 77	Son fournies en unités pos. 77	Sind im Umschlag Bez. Nr 77	Provisto en grupo pos. 77	
d				Forniti anche in gruppo pos. 78, 79, 80, 81	Supplied in bag ref. N° 78, 79, 80, 81	Son fournies en unités pos. 78, 79, 80, 81	Sind im Umschlag Bez. Nr 78, 79, 80, 81	Provisto en grupo pos. 78, 79, 80, 81	

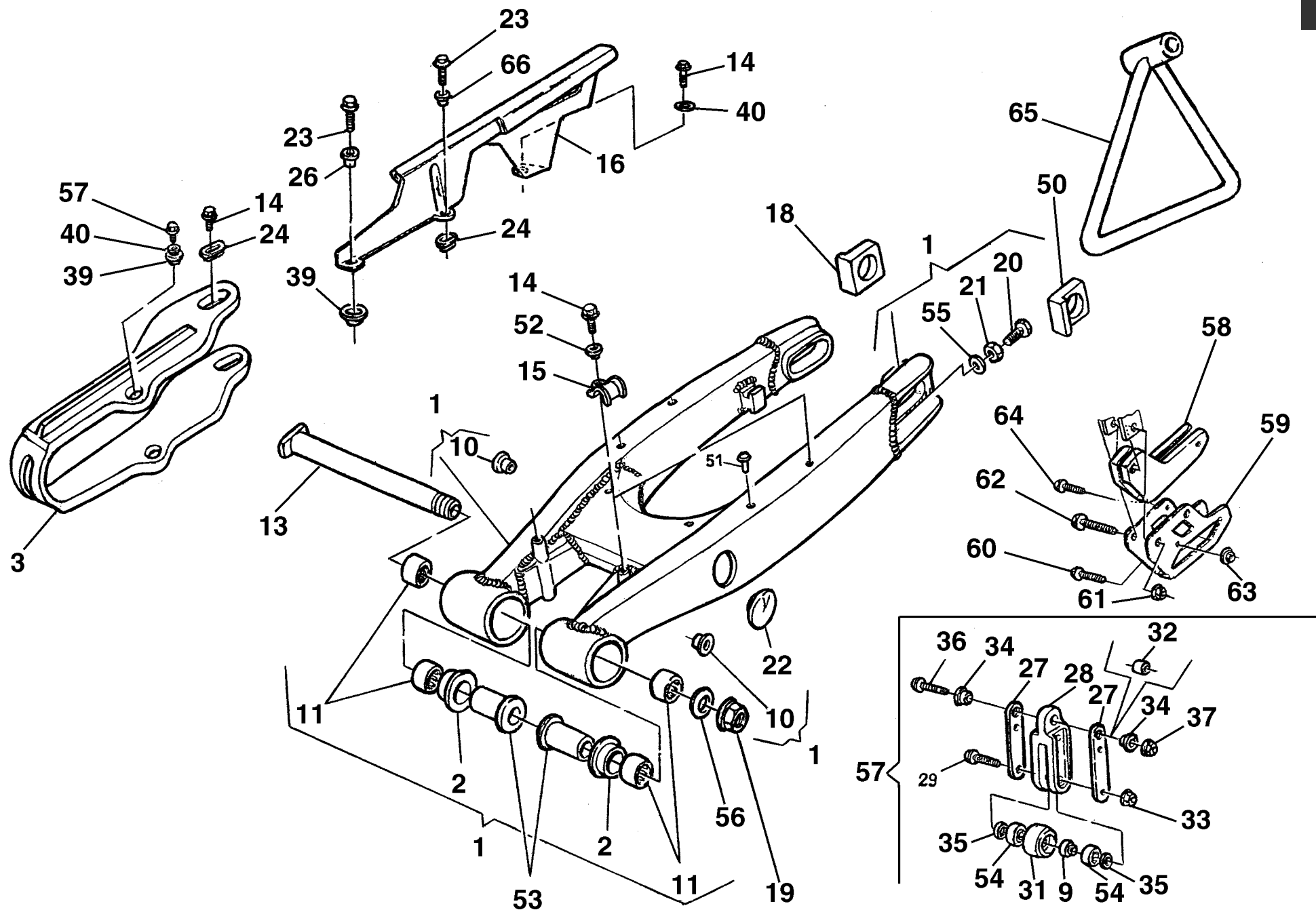



WR - CR 250/2001 ;
WR 360/2001

TAVOLA
DRAWING
TABLE
BILD
TABLA

16

FORCELLONE - SWING ARM
FOURCHE - GABEL
HORQUILLA

Note Notes Marken Notas	Pos. No. N. Index Pos.	N. Cod. Code No. Nr. Code Code Nr N. Cod.	Q.tà Q.ty Q.te M.ge C.ad	DENOMINAZIONE	NAME	DESIGNATION	BESHREIBUNG	DENOMINACION	Validità Validity Validité Gültig Validez
W	1	8000 97151	1	Forcellone completo	Compl. fork	Fourche complete	Gabel, Kpl.	Horquilla compl.	
CU	1	8000 97036	1	Forcellone completo	Compl. fork	Fourche complete	Gabel, Kpl.	Horquilla compl.	
	2	8000 71622	4	Bussola	Bushing	Douille	Buchse	Manguito	
	3	8000 96960	1	Pattino catena	Chain slider	Glissière	Gleitbahn	Plato catena	
	6	8000 01412	2	Ingrassatore	Lubricator	Graisser	Schmierbüchse	Lubricador	
W	9	8000 65412	1	Distanziale	Spacer	Entretoise	Distanzstück	Separador	
	10	8000 87810	1	Bussola Dx	R.H. bushing	Douille D.	Buchse Rechte	Manguito der.	
	10	8A00 87810	1	Bussola Sx	L.H. bushing	Douille G.	Buchse Linke	Manguito iz.	
	11	8000 76283	4	Gabbia a rullini (ø22xø28x18mm)	Needle cage (ø22xø28x18mm)	Cage à aiguilles (ø22xø28x18mm)	Nadelkaefig (ø22xø28x18mm)	Jaula de agujas del cojinete (ø22xø28x18mm)	
	13	8000 71620	1	Perno forcellone	Fork pin	Pivot fourche	Gabelbolzen	Perno horquilla	
	14	8000 67997	1	Vite anteriore	Front screw	Vis avant	Vord. Schraube	Tornillo delantero	
	14	8000 20536	2	Vite posteriore	Rear screw	Vis arriere	Hint. Schraube	Tornillo trasero	
	15	80A0 73456	3	Guidacavo	Cable guide	Guide câble	Kabelführung	Guía-cable	
XY	16	80A0 73426	1	Copricatena	Chain guard	Carter de chaine	Kettenkasten	Cubre-cadena	
	18	8000 96944	2	Tendicatena DX	Chain adjuster R.	Tendeur de chaine D.	Kettenspanner R.	Tensor de cadena D.	
	19	8000 71623	1	Dado	Nut	Ecrou	Mutter	.Tuerca	
	20	8C00 61121	2	Vite	Screw	Vis	Schraube	Tornillo	
	21	8000 17810	2	Dado	Nut	Ecrou	Mutter	Tuerca	
	22	80A0 74388	2	Tappo	Plug	Bouchon	Verschluss	Tapón	
W	23	8000 67997	2	Vite inf.	Screw	Vis	Schraube	Tornillo	
W	23	8A00 67997	2	Vite sup.	Screw	Vis	Schraube	Tornillo	
UC	23	8000 67997	4	Vite	Screw	Vis	Schraube	Tornillo	
	24	8000 59289	2	Scodellino	Cup	Cuvette	Teller	Cubeta	
YX	26	8A00 69282	2	Bussola	Bushing	Douille	Buchse	Manguito	
Y	27	8000 72875	2	Piastra d'attacco	Plate	Plaque	Platte	Placa	
Y	28	8000 72874	1	Guidacatena	Chain guide	Guide-chaine	Kettenführung	Guía-cadena	
Y	29	8000 62731	2	Vite	Screw	Vis	Schraube	Tornillo	
Y	31	8000 65411	1	Rullo	Roller	Aiguille	Rolle	Rodillo	
Y	32	1515 50601	1	Bussola	Bushing	Douille	Buchse	Manguito	
Y	33	8000 44240	2	Dado	Nut	Ecrou	Mutter	Tuerca	
Y	34	8A00 66661	2	Bussola	Bushing	Douille	Buchse	Manguito	

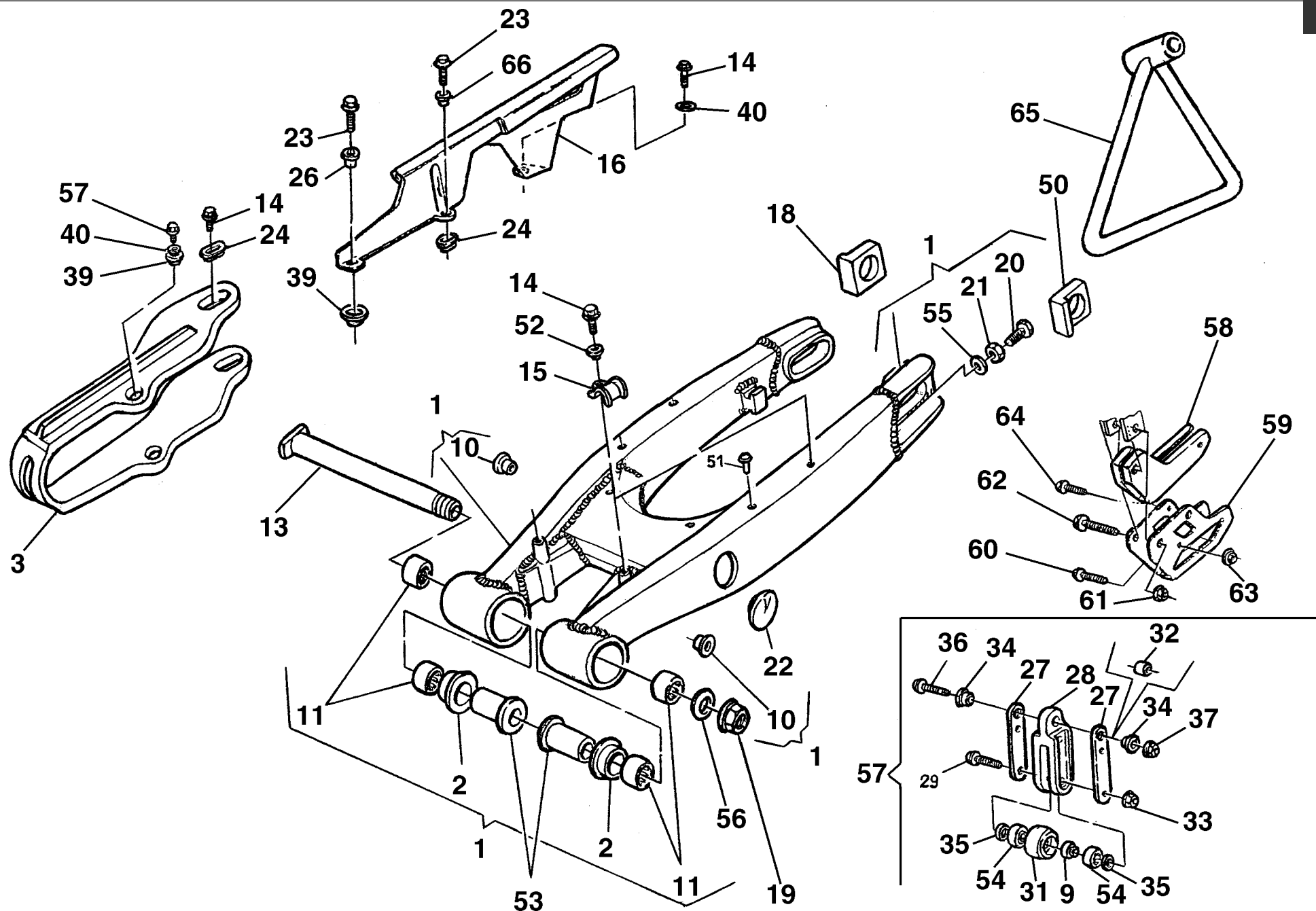



WR - CR 250/2001 ;
WR 360/2001

TAVOLA
DRAWING
TABLE
BILD
TABLA

16

FORCELLONE - SWING ARM
FOURCHE - GABEL
HORQUILLA

Note Notes Notas	Pos. No. Index Pos.	N. Cod. Code No. Nr. Code Code Nr N. Cod.	Q.tà Q.ty Q.te M.ge C.ad	DENOMINAZIONE	NAME	DESIGNATION	BESHREIBUNG	DENOMINACION	Validità Validity Validité Gültig Validez
Y	35	8000 45495	2	Boccola di spallamento	Washer	Rondelle	Scheibe	Arandela	
Y	36	8000 62795	2	Vite	Screw	Vis	Schraube	Tornillo	
Y	37	8000 43928	1	Dado	Nut	Ecrou	Mutter	Tuerca	
	39	8000 75166	2	Scodellino	Cup	Cuvette	Teller	Cubeta	
W	40	8000 36137	2	Rosetta piana	Washer	Rondelle	Scheibe	Arandela	
UC	40	8000 36137	4	Rosetta piana	Washer	Rondelle	Scheibe	Arandela	
	50	8000 96941	1	Tendicatena SX	Chain adjuster L.	Tendeur de chaine G.	Kettenspanne L.	Tensor de cadena l.	
	51	8000 75160	4	Rivetto	Rivet	Rivet	Niet	Remache	
	52	8000 69282	2	Bussola	Bushing	Douille	Buchse	Manguito	
	53	8000 71621	2	Bussola	Bushing	Douille	Buchse	Manguito	
Y	54	8000 63312	2	Cuscinetto (ø8xØ22x7mm)	Bearing (ø8xØ22x7mm)	Roulem'ent (ø8xØ22x7mm)	Lager (ø8xØ22x7mm)	Cojinete (ø8xØ22x7mm)	
	55	8000 08536	2	Rosetta	Washer	Rondelle	Scheibe	Arandela	
	56	8000 32388	2	Rosetta	Washer	Rondelle	Scheibe	Arandela	
Y	57	8000 72873	1	Ass. guidacatena	Chain guide assy	Groupe guide chaine	Kettenführungsgruppe Kpl.	Grupo guiacadena	
C	58	8000 72868	1	Guidacatena	Chain guide	Guidechaine	Kettenführung	Guiacadena	
C	59	8000 72869	1	Staffa	Bracket	Entier	Buegel	Brida	
C	60	8A00 69056	2	Vire (M8x45mm)	Screw (M8x45mm)	Vis (M8x45mm)	Schraube (M8x45mm)	Tornillo (M8x45mm)	
C	61	8000 43928	1	Dado	Nut	Ecrou	Mutter	Tuerca	
C	62	8000 62731	1	Vite (M6x45mm)	Screw (M6x45mm)	Vis (M6x45mm)	Schraube (M6x45mm)	Tornillo (M6x45mm)	
C	63	8000 44240	1	Dado	Nut	Ecrou	Mutter	Tuerca	
C	64	8000 62725	1	Vire (M6x10mm)	Screw (M6x10mm)	Vis (M6x10mm)	Schraube (M6x10mm)	Tornillo (M6x10mm)	
C	65	8000 74016	1	Gamba laterale	Side stand	Bequille lat.	Seitenstander	Horquilla lateral	
W	66	8000 97025	2	Bussola	Bushing	Douille	Buchse	Manguito	
W	67	60N1 01059	1	Vite (M5x35mm)	Screw (M5x35mm)	Vis (M5x35mm)	Schraube (M5x35mm)	Tornillo (M5x35mm)	

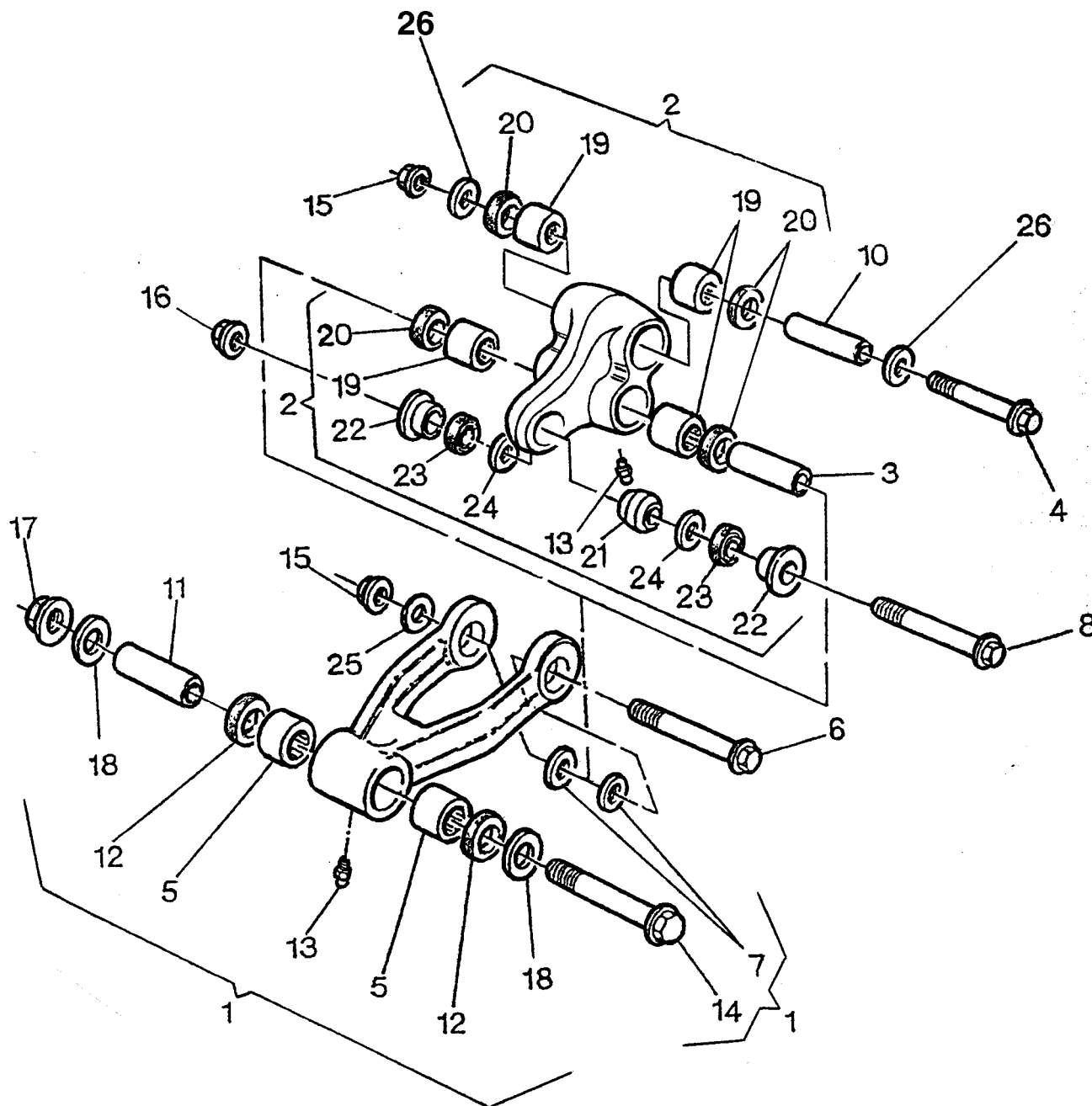



WR - CR 250/2001 ;
WR 360/2001

TAVOLA
DRAWING
TABLE
BILD
TABLA

16A

LEVERAGGI SOSPENSIONE POSTERIORE - REAR SUSPENSION LINKAGE
LEVIER SUSPENSION ARRIERE - HEBELWERK HINTERHAUFHANGUNG
PALANCA SUSPENSION TRASERA

Note Notes Notas	Pos. No. Index	N. Cod. Code No. Nr. Code Code Nr N. Cod.	Q.tà Q.ty Q.te M.ge C.ad	DENOMINAZIONE	NAME	DESIGNATION	BESHREIBUNG	DENOMINACION	Validità Validity Validité Gültig Validez
	1	8000 96922	1	Tirante completo	Tie rod	Tirant	Spannstange	Tirante	
	2	8000 96923	1	Assieme bilanciare	Rocking lever assy	Balancier compl.	Schwinge Kpl.	Balancines compl.	
	3	8000 86176	1	Spinotto	Gudgeon	Axe	Bolzen	Perno	
	4	8A00 86138	1	Perno (M12x106 mm)	Pin (M12x106 mm)	Pivot (M12x106 mm)	Bolzen (M12x106 mm)	Perno (M12x106 mm)	
	5	8000 86136	2	Boccola a rullini (ø22xØ28x16 mm)	Rollenbush (ø22xØ28x16 mm)	Douille rouleaux (ø22xØ28x16 mm)	Rollerbuchse (ø22xØ28x16 mm)	Casquillo (ø22xØ28x16 mm)	
	6	8000 93124	1	Perno (M12x103 mm)	Pin (M12x103 mm)	Pivot (M12x103 mm)	Bolzen (M12x103 mm)	Perno (M12x103 mm)	
	7	8000 86177	2	Bussola	Bushing	Douille	Buchse	Manguito	
	8	8D00 62797	1	Perno (M10x47 mm)	Pin (M10x47 mm)	Pivot (M10x47 mm)	Bolzen (M10x47 mm)	Perno (M10x47 mm)	
	10	8000 86176	1	Spinotto	Gudgeon	Axe	Bolzen	Perno	
	11	8A00 86176	1	Spinotto	Gudgeon	Axe	Bolzen	Perno	
	12	8000 38521	2	Anello di tenuta (ø22xØ28x4 mm)	Seal ring (ø22xØ28x4 mm)	Bague d'étanchéité (ø22xØ28x4 mm)	Dichtungsring (ø22xØ28x4 mm)	Anillo de retención (ø22xØ28x4 mm)	
	13	8000 01412	2	Ingrassatore	Lubricator	Graisseur	Schmierbüchse	Lubricador	
	14	8C00 86138	1	Perno (M12x81 mm)	Pin (M12x81 mm)	Pivot (M12x81 mm)	Bolzen (M12x81 mm)	Perno (M12x81 mm)	
	15	8000 42023	2	Dado	Nut	Ecrou	Mutter	Tuerca	
	16	8000 42022	2	Dado	Nut	Ecrou	Mutter	Tuerca	
	17	8000 42023	1	Dado	Nut	Ecrou	Mutter	Tuerca	
	18	8000 86140	2	Anello di spugna	Ring	Bague	Ring	Anillo	
	19	8000 86136	4	Boccola a rullini (ø22xØ28x16 mm)	Rollenbush (ø22xØ28x16 mm)	Douille rouleaux (ø22xØ28x16 mm)	Rollerbuchse (ø22xØ28x16 mm)	Casquillo (ø22xØ28x16 mm)	
	20	8000 86137	4	Anello di tenuta	Seal ring	Bague d'étanchéité	Dichtungsring	Anillo de retención	
	21	8000 72168	1	Snodo a sfera	Ball joint	Joint a rotule	Kugelgelenk	Articulacion esferica	
	22	1511 33302	2	Bussola	Bushing	Douille	Buchse	Manguito	
	23	8000 38767	2	Anello di tenuta	Seal ring	Bague d'étanchéité	Dichtungsring	Anillo de retención	
	24	8000 90561	2	Anello di tenuta ø24xØ28x2mm	Seal ring ø24xØ28x2mm	Bague d'étanchéité ø24xØ28x2mm	Dichtungsring ø24xØ28x2mm	Anillo de retención ø24xØ28x2mm	
	26	8000 86177	2	Bussola	Bushing	Douille	Buchse	Manguito	

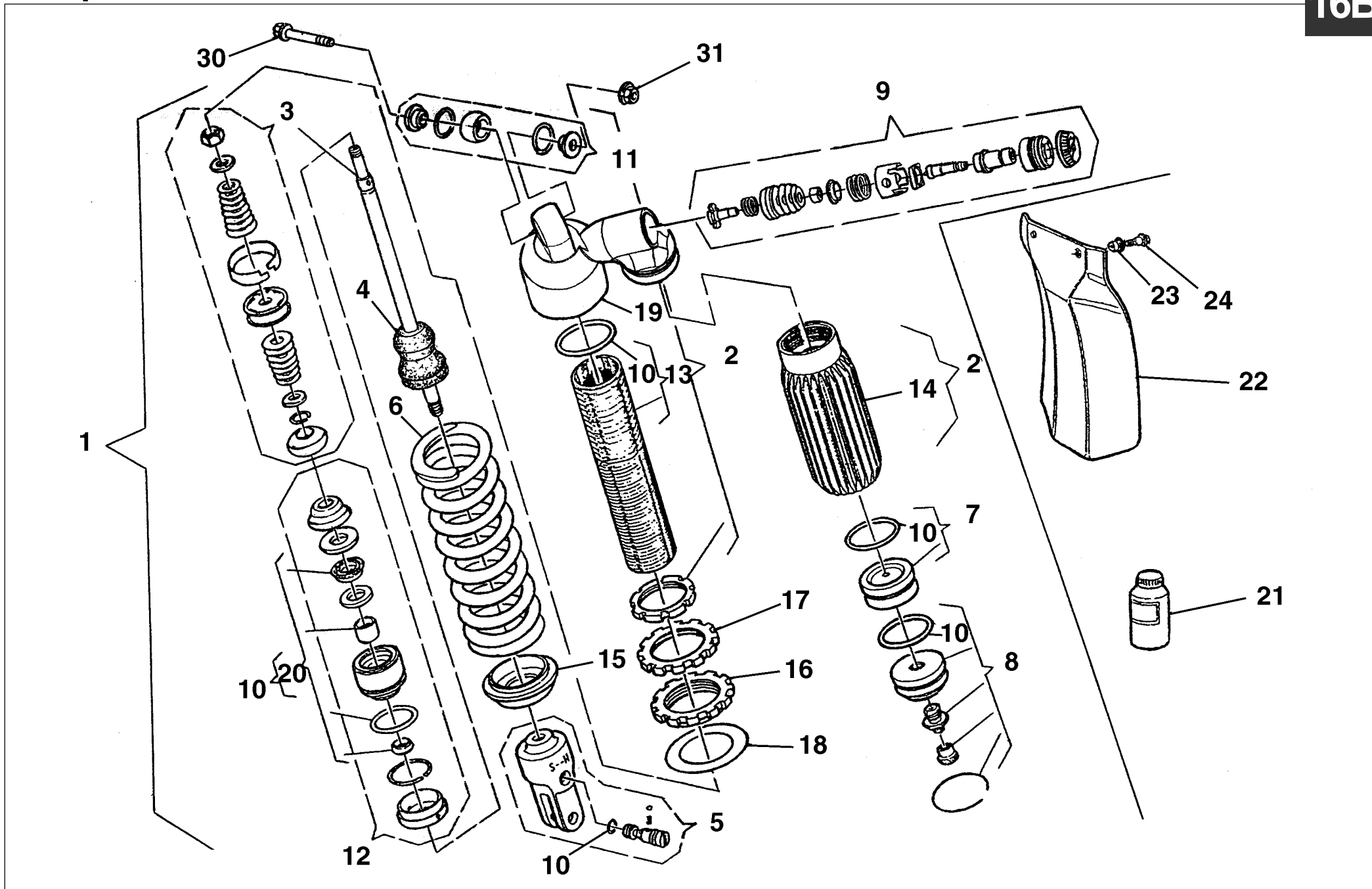



WR - CR 250/2001 ;
WR 360/2001

TAVOLA
DRAWING
TABLE
BILD
TABLA

16B

AMMORTIZZATORE POSTERIORE- REAR SUSPENSION
SUSPENSION ARRIERE- HINTERHAUFHANGUNG
SUSPENSION TRASERA

Note Notes Notas	Pos. No. Index Pos.	N. Cod. Code No. Nr. Code Code Nr N. Cod.	Q.tà Q.ty Q.te M.ge C.ad	DENOMINAZIONE	NAME	DESIGNATION	BESHREIBUNG	DENOMINACION	Validità Validity Validité Gültig Validez
W	1	8000 97152	1	Ammortizzatore completo	Shock-absorber	Ammortisseur	Stossdämpfer	Amortiguador	
C	1	8000 97038	1	Ammortizzatore completo	Shock-absorber	Ammortisseur	Stossdämpfer	Amortiguador	
	2	8000 98500	1	Gruppo corpo	Damper case assy	Groupe corps amortisseur	Stossdämpferkörper Kpl.	Corpo amortiguador compl.	
W	3	8000 98507	1	Gruppo stelo	Rod assy	Groupe tige	Pumpenstückgruppe	Grupo espiga	
C	3	8000 98510	1	Gruppo stelo	Rod assy	Groupe tige	Pumpenstückgruppe	Grupo espiga	
	4	8000 91238	1	Tampone	Pad	Tampon	Stopfen	Tampón	
	5	8000 98489	1	Gruppo forcella	Fork assy	Groupe fourche	Gabelgruppe Kpl.	Grupo horquilla	
C	6	8000 98569	1	Molla (k=5,2 Kg/mm)	Spring (k=5,2 Kg/mm)	Ressort (k=5,2 Kg/mm)	Feder (k=5,2 Kg/mm)	Resorte (k=5,2 Kg/mm)	
W	6	8000 98570	1	Molla (k=5,4 Kg/mm)	Spring (k=5,4 Kg/mm)	Ressort (k=5,4 Kg/mm)	Feder (k=5,4 Kg/mm)	Resorte (k=5,4 Kg/mm)	
	7	8000 98490	1	Diaframma	Diaphragm	Diaphragme	Biegeplatte	Diafragma	
	8	8000 98491	1	Gruppo serbatoio	Tank assy	Groupe reservoir	Tankgruppe Kpl.	Grupo deposito compl.	
	9	8000 98492	1	Gruppo regolazione	Adjusterset	Groupe réglage	Reglergruppe Kpl.	Grupo regulacion	
	10	8000 98493	1	Gruppo guarnizioni	Gasketset	Groupe garnitures	Dichtungssatz	Grupo juntas	
	11	8000 89089	1	Gruppo snodo	Ball joint assy	Groupe joint a rotule	Kugelgelenkgruppe Kpl.	Grupo articulaciòn esferica	
	12	8000 98494	1	Gruppo guida stelo	Guide rod assy	Groupe guide tige	Pumpenstückführungsgruppe	Grupo guja espiga	
	13	8000 98501	1	Corpo ammortizzatore	Damper case	Corps amortisseur	Stossdämpferkörper	Corpo amortiguador	
	14	8000 98502	1	Serbatoio	Tank	Reservoir	Tank	Deposito	
	15	8000 98496	1	Fondello	Bottom	Fond	Bodenscheibe	Casquillo	
	16	8000 98497	1	Ghiera	Ring nut	Embout	Nutmutter	Virola	
	17	8000 98498	1	Ghiera	Ring nut	Embout	Nutmutter	Virola	
	18	8000 98499	1	Rosetta per molla	Washer	Rondelle	Scheibe	Arandela	
	19	8000 98503	1	Supporto serbatoio	Tank support	Support reservoir	Gastankhalterung	Soporte deposito	
	20	8000 98495	1	Gruppo guarnizioni per stelo	Rod gasket set	Jeu joints pour tige	Dichtungssatz für Pumpenstock	Serie juntas por espiga	
R	21	8000 88231	1	Olio ammortizzatore	Shock-absorber oil	Huile amortisseur	Öl für Stossdämpfer	Aceite amortiguador	
	22	80A0 69551	1	Protezione ammortizzatore	Guard	Protection	Schutz	Protección	
	23	8000 69429	2	Bussola	Bushing	Douille	Buchse	Manguito	
	24	8000 62726	2	Vite	Screw	Vis	Schraube	Tornillo	

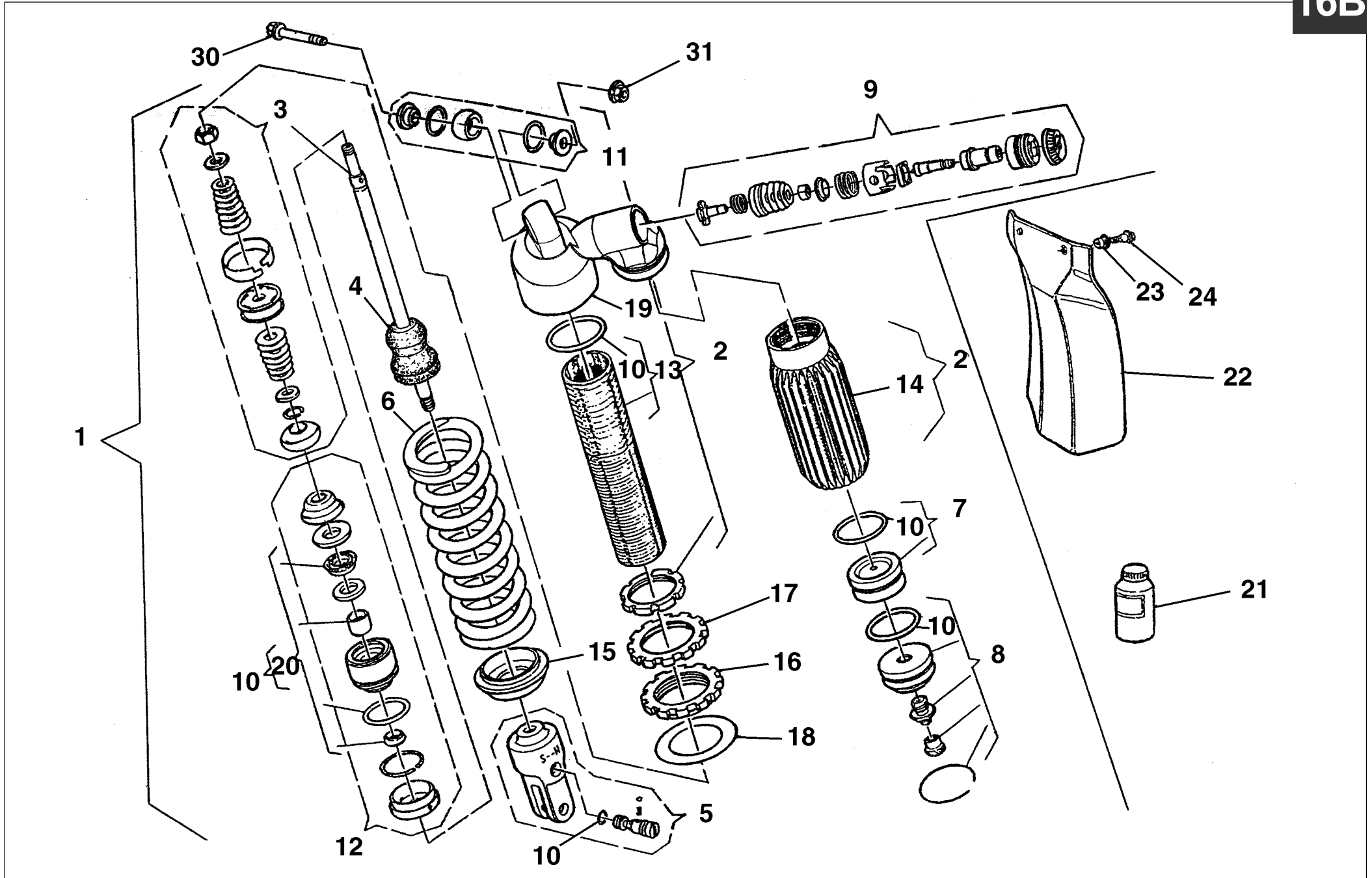

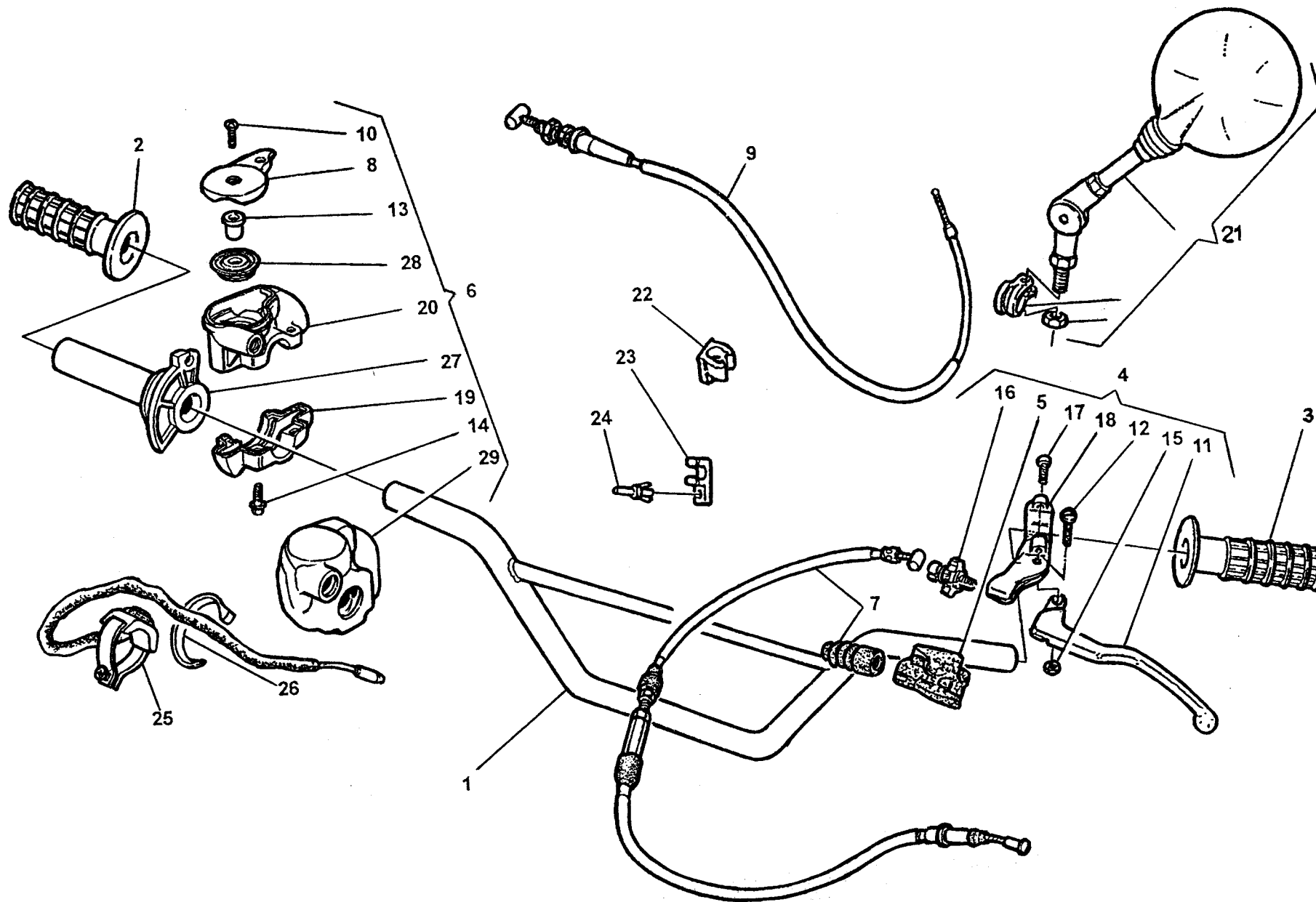



WR - CR 250/2001 ;
WR 360/2001

TAVOLA
DRAWING
TABLE
BILD
TABLA

17

MANUBRIO E COMANDI - HANDLEBAR AND CONTROLS
GUIDON ET COMMANDES - LENKER UND STEUERORGANE
MANILLAR Y MANDOS

Note Notes Notas	Pos. No. Index Pos.	N. Cod. Code No. Nr. Code Code Nr N. Cod.	Q.tà Q.ty Q.te M.ge C.ad	DENOMINAZIONE	NAME	DESIGNATION	BESHREIBUNG	DENOMINACION	Validità Validity Validité Gültig Validez
W	1	80C0 53018	1	Manubrio	Handlebar	Guidon	Lenker	Manillar	
C	1	8000 88280	1	Manubrio (alluminio)	Handlebar (aluminium)	Guidon (aluminium)	Lenker (aluminium)	Manillar (aluminio)	
R	1	8000 88280	1	Manubrio (alluminio)	Handlebar (aluminium)	Guidon (aluminium)	Lenker (aluminium)	Manillar (aluminio)	
	2	8000 76688	1	Manopola destra	R.H. grip	Poignée G.	Griff R.	Manopla der.	
	3	8000 76687	1	Manopola sinistra	L.H. grip	Poignée G.	Griff L.	Manopla izq.	
	4	8000 75330	1	Com. frizione completo	Clutch trasm. assy	Trasm. embrayage compl.	Führungssteuerung	Mando embrague compl.	
	5	8000 48917	1	Coprileva	Lever cover	Couvre levier	Hebeldeckel	Cubre-palanca	
	6	8000 88865	1	Comando gas completo	Throttle control compl.	Commande gaz compl.	Gasgriff kpl.	Accionamiento acelerador com.	
	7	8000 76284	1	Trasm. comando frizione (360)	Clutch transm. (360)	Transm.com.embrayage (360)	Führungssteuerung (360)	Trans. mando embrague (360)	
	7	8000 90710	1	Trasm. comando frizione (250)	Clutch transm. (250)	Transm.com.embrayage (250)	Führungssteuerung (250)	Trans. mando embrague (250)	
	8	8000 93751	1	Coperchietto	Cover	Couvercle	Deckel	Tapa	
	9	8000 92308	1	Trasmissione gas	Throttle trasm.	Trasm. comm. gaz	Führungsteuerung des Gases	Tran. mando acelerador compl.	
	10	8000 50798	2	Vite	Screw	Vis	Schraube	Tornillo	
	11	8000 77737	1	Leva comando frizione	Clutch lever	Levier embrayage	Kupplungshebel	Palanca mando embrague	
	12	8000 38797	1	Vite	Screw	Vis	Schraube	Tornillo	
	13	8000 93750	1	Bussola	Bush	Douille	Buchse	Manguito	
	14	8000 62728	2	Vite	Screw	Vis	Schraube	Tornillo	
	15	8000 87812	1	Dado	Nut	Ecrou	Mutter	Tuerca	
	16	8000 48916	1	Gruppo registro	Adjuster set	Groupe reglage	Kupplungsreglergruppe	Grupo regul.	
	17	8000 62728	2	Vite	Screw	Vis	Schraube	Tornillo	
	18	8000 70698	1	Cavallotto	U-bolt	Cavalier	Bügelbolzen	Caballote	
	19	8000 93747	1	Supporto inferiore	Lower support	Support inférieur	Untere Halterung	Soporte inferior	
	20	8000 93746	1	Supporto superiore	Upper support	Support supérieur	Obere Halterung	Soporte superior	
XYD	21	8000 65437	2	Specchio retrovisore compl.	Driving mirror	Rétroviseur	Rückspiegel	Espejo retrovisor	
	22	8000 61068	1	Molletta guida trasmissioni	Cable guida	Guide cable	Kabelführung	Guia-cable	
	23	8000 85220	1	Molletta guida trasmissioni	Cable guida	Guide cable	Kabelführung	Guia-cable	
	24	8000 48966	1	Rivetto	Rivet	Rivet	Niet	Remache	
UC	25	8000 96828	1	Pulsante arresto motore	Engine stop switch	Bouton d'arrêt moteur	Motoranhaltschalter	Pulsador parada motòr	
UC	26	8000 71578	2	Fascetta	Clamp	Collier	schelle	banda	
	27	8000 93748	1	Tubo gas	Throttle pipe	Tuyau gaz	Gasrohr	Tubo aceleradòr	

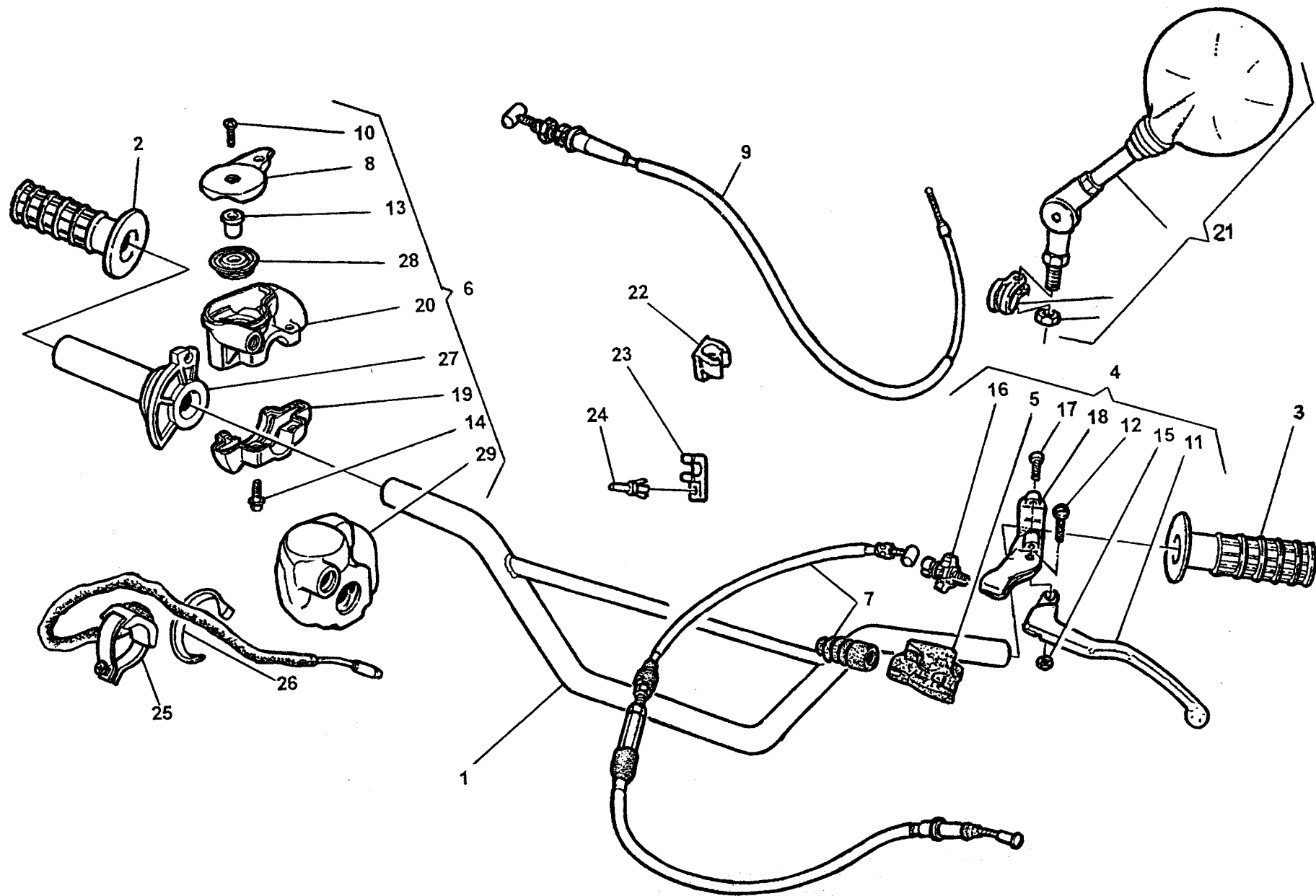

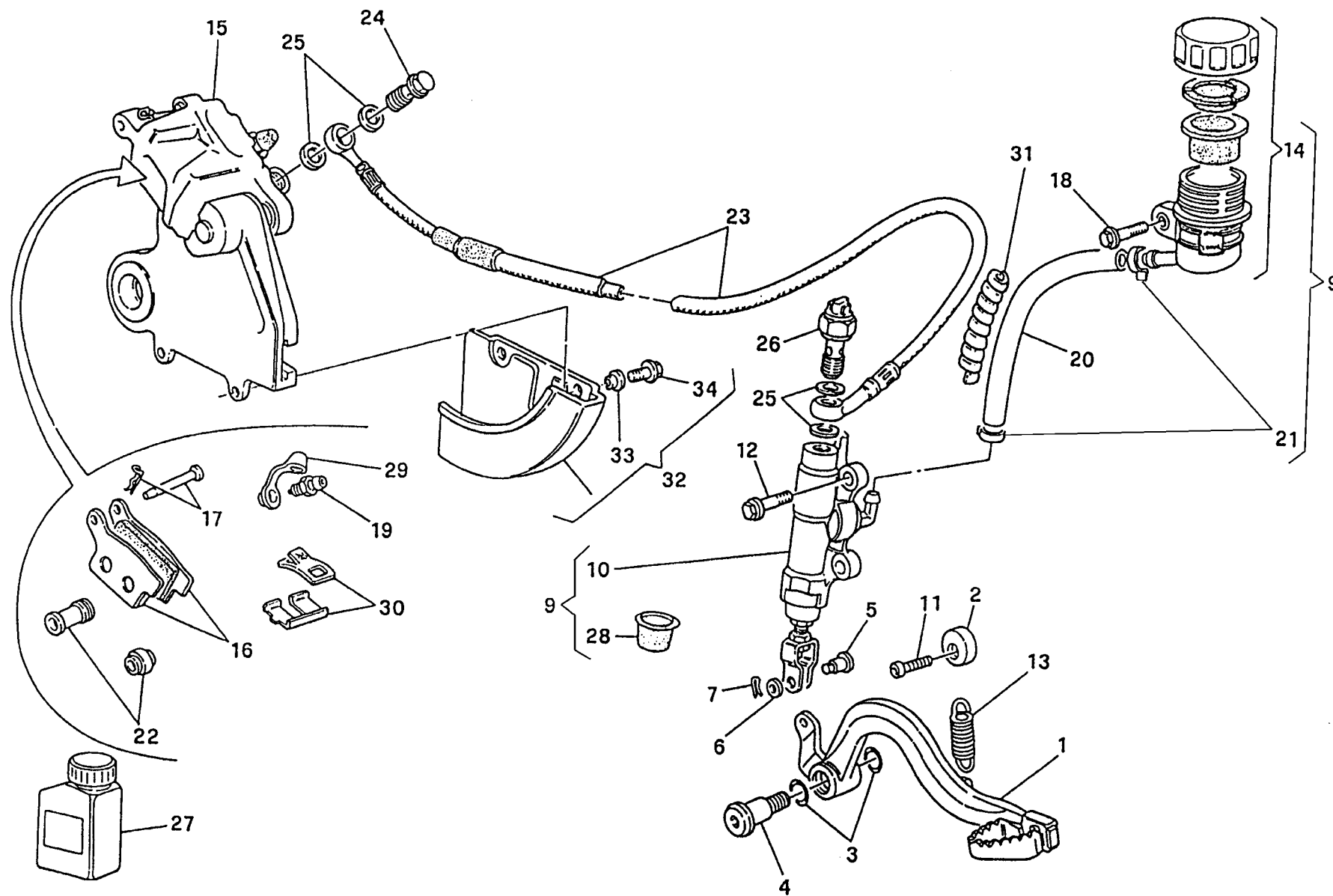



WR - CR 250/2001 ;
WR 360/2001

TAVOLA
DRAWING
TABLE
BILD
TABLA

18

FRENO IDRAULICO POSTERIORE - REAR HYDRAULIC BRAKE
FREIN HYDRAULIQUE ARRIERE - HINTERBREMSE
FRENO HIDRAULICO TRASERO

Note Notes Notas	Pos. No. Index Pos.	N. Cod. Code No. Nr. Code Code Nr N. Cod.	Q.tà Q.ty Q.te M.ge C.ad	DENOMINAZIONE	NAME	DESIGNATION	BESHREIBUNG	DENOMINACION	Validità Validity Validité Gültig Validez
	1	8A00 73343	1	Leva comando freno	Brake control lever	Levier comm. frein	Bremshebel	Palanca accionamiento freno	
	2	8000 69125	1	Camma	Cam	Came	Nocken	Exéncrico	
	3	8000 22551	2	Anello OR	O-Ring	Bague OR	O-Ring	Anillo OR	
	4	8000 55902	1	Vite	Screw	Vis	Schraube	Tornillo	
	5	8000 70696	1	Perno	Pin	Pivot	Bolzen	Perno	
	6	8000 56377	1	Rosetta	Washer	Rondelle	Scheibe	Arandela	
	7	64N1 20068	1	Copiglia	Split pin	Goupille	Splint	Clavija	
	9	8A00 76026	1	Ass. pompa freno	Brake pump assy	Groupe pompe frein	Bremspumpegruppe	Grupo bomba freno	
	10	8000 76338	1	Pompa freno	Brake pump	Pompe frein	Bremspumpe	Bomba freno	
	11	8A00 55241	1	Vite	Screw	Vis	Schraube	Tornillo	
	12	8000 62726	2	Vite	Screw	Vis	Schraube	Tornillo	
	13	8000 55903	1	Molla	Spring	Ressort	Feder	Resorte	
	14	8000 61078	1	Serbatoio olio completo	Oil tank assy	Reservoir huile compl.	Öltank Kpl.	Depósito aceite completo	
	15	8A00 77745	1	Pinza freno completa	Brake caliper assy	Pince de frein, compl.	Bremszange, Kpl.	Pinza freno compl.	
	16	8000 79072	1	Coppia pastiglie	Pads pair	Paire plaquettes	Bremsbelagpaar	Pareja pastillas	
R	16	8A00 79072	1	Coppia pastiglie sinterizzate	Pads pair sinterized	Paire plaquettes frittage	Bremsbelagpaar sistem	Pareja pastillas sinterizar	
	17	8000 87153	1	Perno	Pin	Pivot	Bolzen	Perno	
	18	8000 62725	1	Vite	Screw	Vis	Schraube	Tornillo	
	19	8000 60404	1	Spurgo	Spurgo	Drain	Entleerung	Purga	
	20	8000 70266	1	Tubazione	Pipe	Tuyau	Rohr	Tubo	
	21	8000 42349	1	Molletta	Spring	Ressort	Feder	Resorte	
	22	8000 79066	1	Cuffia	Boots	Poussiers	haube	Gorro	
E	23	8000 77980	1	Tubo mandata olio (360)	Pipe (360)	Tuyau (360)	Rohr (360)	Tubo (360)	
	23	8000 88863	1	Tubo mandata olio	Pipe	Tuyau	Rohr	Tubo	
	24	8000 57155	1	Vite	Screw	Vis	Schraube	Tornillo	
	25	8000 21480	4	Rosetta di tenuta	Washer	Rondelle	Scheibe	Arandela	
W	26	8000 94849	1	Interruttore stop posteriore	Stop switch	Interrupteur stop	Stopschalter	Interruptor stop	
UC	26	8000 57155	1	Vite	Screw	Vis	Schraube	Tornillo	
R	27	8000 71445	1	Olio freni	Brake oil	Huile de frein	BremsÖl	Aceite freno	
	28	8000 79075	1	Cuffia	Boot	Poussier	haube	Gorro	
	29	8000 53259	1	Parapolvere	Boots	Para-poudre	Schutzhaube	Para-polvo	
	30	8000 85932	1	Molla-lamierino	Spring-steel clip	Ressort	Feder	Rresorte	

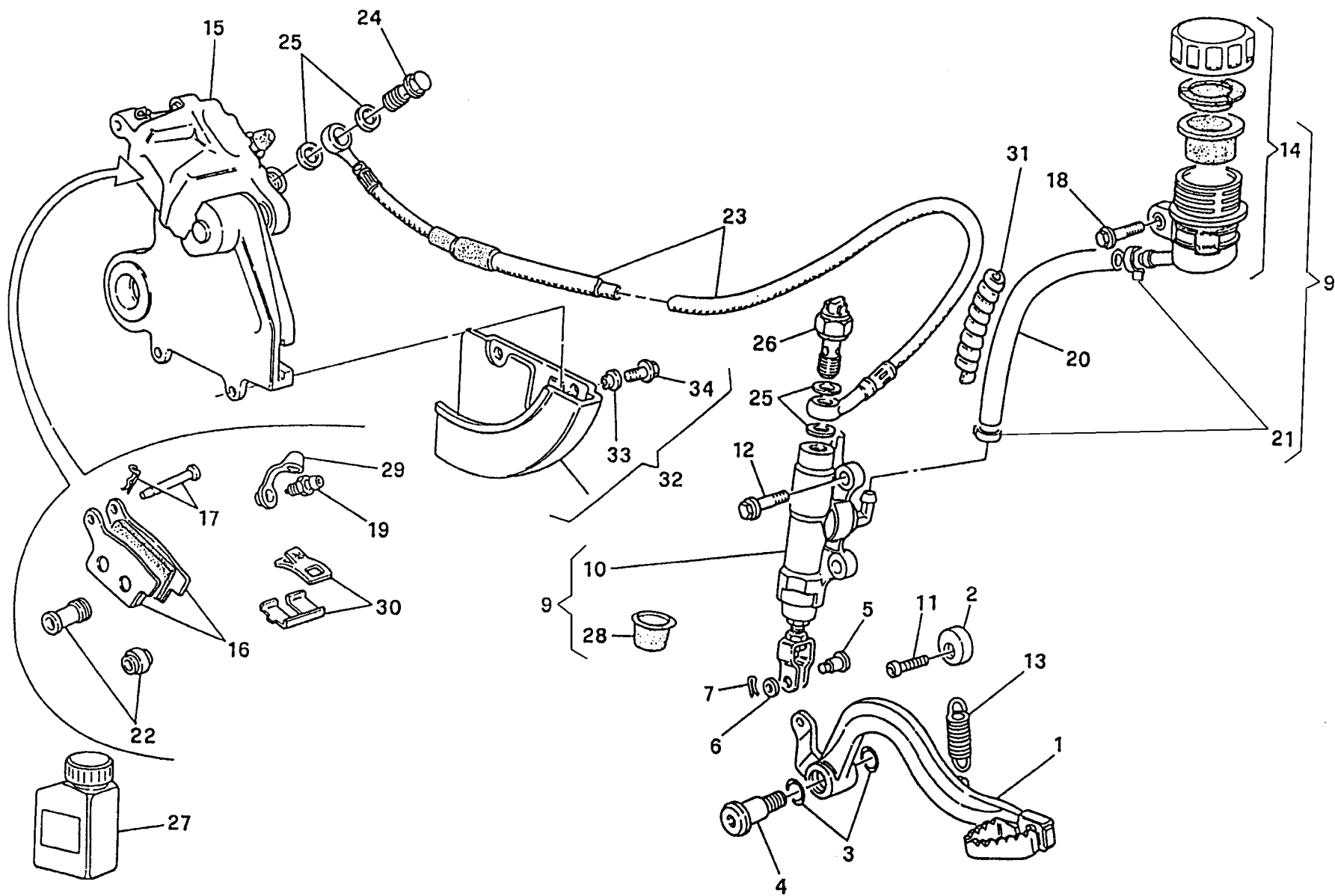

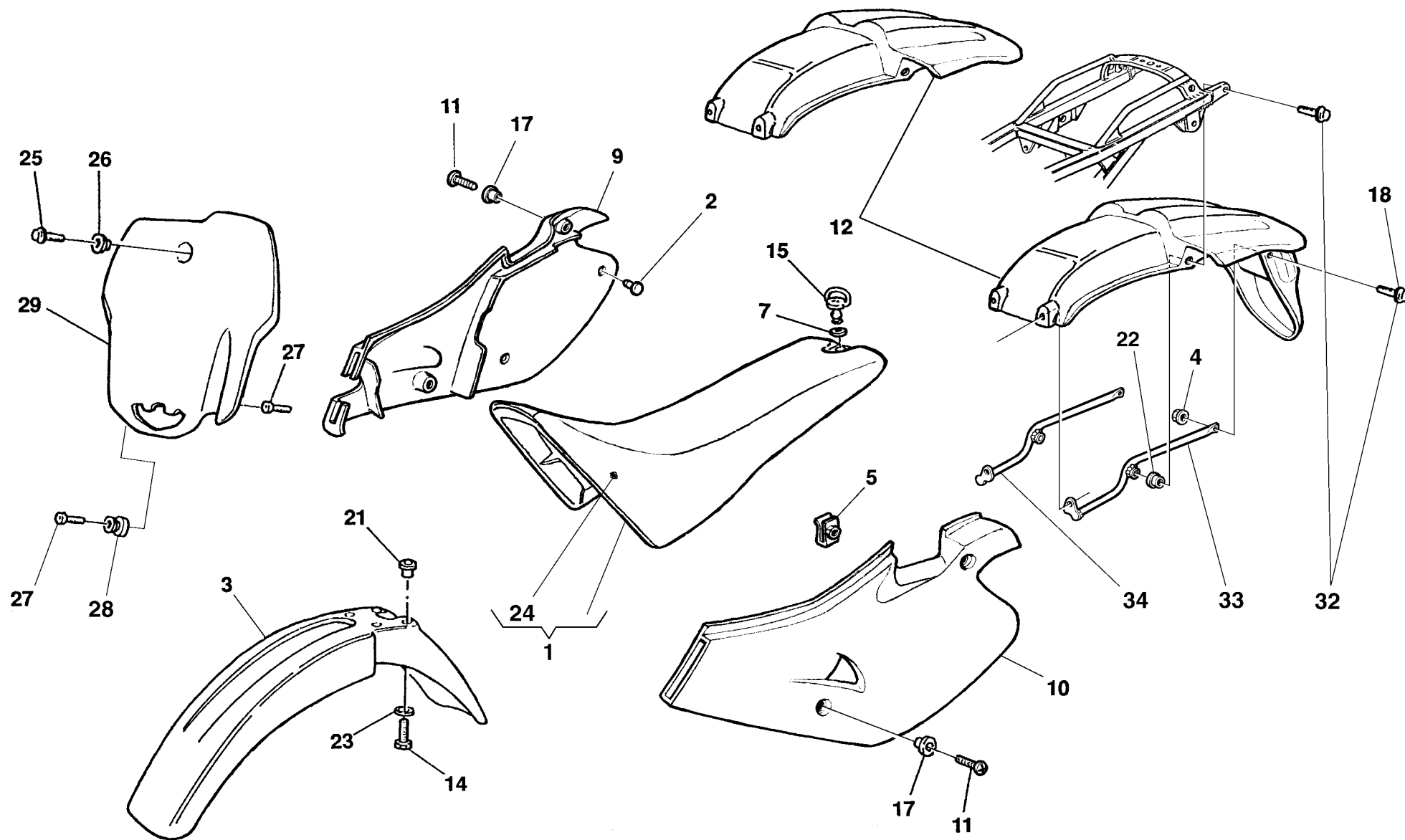



WR - CR 250/2001 ;
WR 360/2001

TAVOLA
DRAWING
TABLE
BILD
TABLA

19

PANNELLI LATERALI, PARAFANGHI, SELLA, LIBRETTO USO E MANUT. - SIDE PANEL, OWNER'S MANUAL
FENDERS, SEAT - PANNEAU, GARDE-BOUES, SIEGE, EMPLOI D'ENTRETIEN - STREIFEN, KOTFLUGEL,
SATTEL, BETRIEBSANLEITUNG - PANELES, GUARDABARROS, SILLIN, FOLLETO DE INSTRUCCIONES

Note Notes Markte Notas	Pos. No. N. Index Pos.	N. Cod. Code No. Nr. Code Code Nr N. Cod.	Q.tà Q.ty Q.te M.ge C.ad	DENOMINAZIONE	NAME	DESIGNATION	BESHREIBUNG	DENOMINACION	Validità Validity Validité Gültig Validez
	1	8000 96945	1	Sella	Seat	Siège	Sattel	Sillín	
	2	8000 45490	2	Gommino	Rubber pad	Pièce caoutchouc	Gummstück	Junta de goma	
	3	80D0 73395	1	Parafango anteriore	Front mudguard	Garde-boue avant	Vord. Kotfluegel	Guarda-barros delantero	
	4	8000 61313	2	Dado	Nut	Ecrou	Mutter	Tuerca	
	5	8000 46893	2	Dado a graffetta	Nut	Ecrou	Mutter	Tuerca	
	7	8000 69149	1	Rosetta elastica	Spring washer	Rondelle élastique	Federscheibe	Arandela elástica	
	9	8000 88866	1	Pannello destro	R.H. panel	Panneau, D.	Streifen, R.	Panel der.	
	10	8000 88867	1	Pannello sinistro	L.H. panel	Panneau, G.	Streifen, L.	Panel izq.	
	11	8000 62727	4	Vite	Screw	Vis	Schraube	Tornillo	
W	12	80A0 88856	1	Parafango posteriore	Rear mudguard	Garde-boue arriere	Hint.Kotfluegel	Guarda-barros trasero	
UC	12	80A0 88927	1	Parafango posteriore	Rear mudguard	Garde-boue arriere	Hint.Kotfluegel	Guarda-barros trasero	
	14	8000 62727	4	Vite	Screw	Vis	Schraube	Tornillo	
	15	8000 69148	4	Perno	Pin	Pivot	Bolzen	Perno	
	17	8000 69429	4	Boccola	Bushing	Douille	Buchse	Casquillo	
	18	8000 62728	2	Vite	Screw	Vis	Schraube	Tornillo	
	21	8000 69429	4	Bussola	Bushing	Douille	Buchse	Manguito	
	22	8000 69429	2	Bussola	Bushing	Douille	Buchse	Manguito	
	23	8000 48814	4	Rosetta	Washer	Rondelle	Scheibe	Arandela	
	24	8000 96946	1	Rivestimento sella	Saddle covering	Revetement selle	Sattelverkleidung	Revestimiento sillín	
UC	25	8C00 67997	1	Vite	Screw	Vis	Schraube	Tornillo	
UC	26	8B00 69282	1	Bussola	Bushing	Douille	Buchse	Manguito	
UC	27	8000 63636	2	Vite	Screw	Vis	Schraube	Tornillo	
UC	28	8A00 69003	2	Distanziale	Spacer	Entretoise	Distanzstück	Separador	
UC	29	80A0 87800	1	Portanumero	Front number holder	Portenumero	Nummerträger	Portanumero	
W	32	8000 62729	4	Vite	Screw	Vis	Schraube	Tornillo	
W	33	8000 95415	1	Supporto Sx parafango	L.H. support	Support G.	Halterung L.	Soporte izquierdo	
W	34	8000 95416	1	Supporto Dx parafango	R.H. support	Support D.	Halterung R.	Soporte derecho	

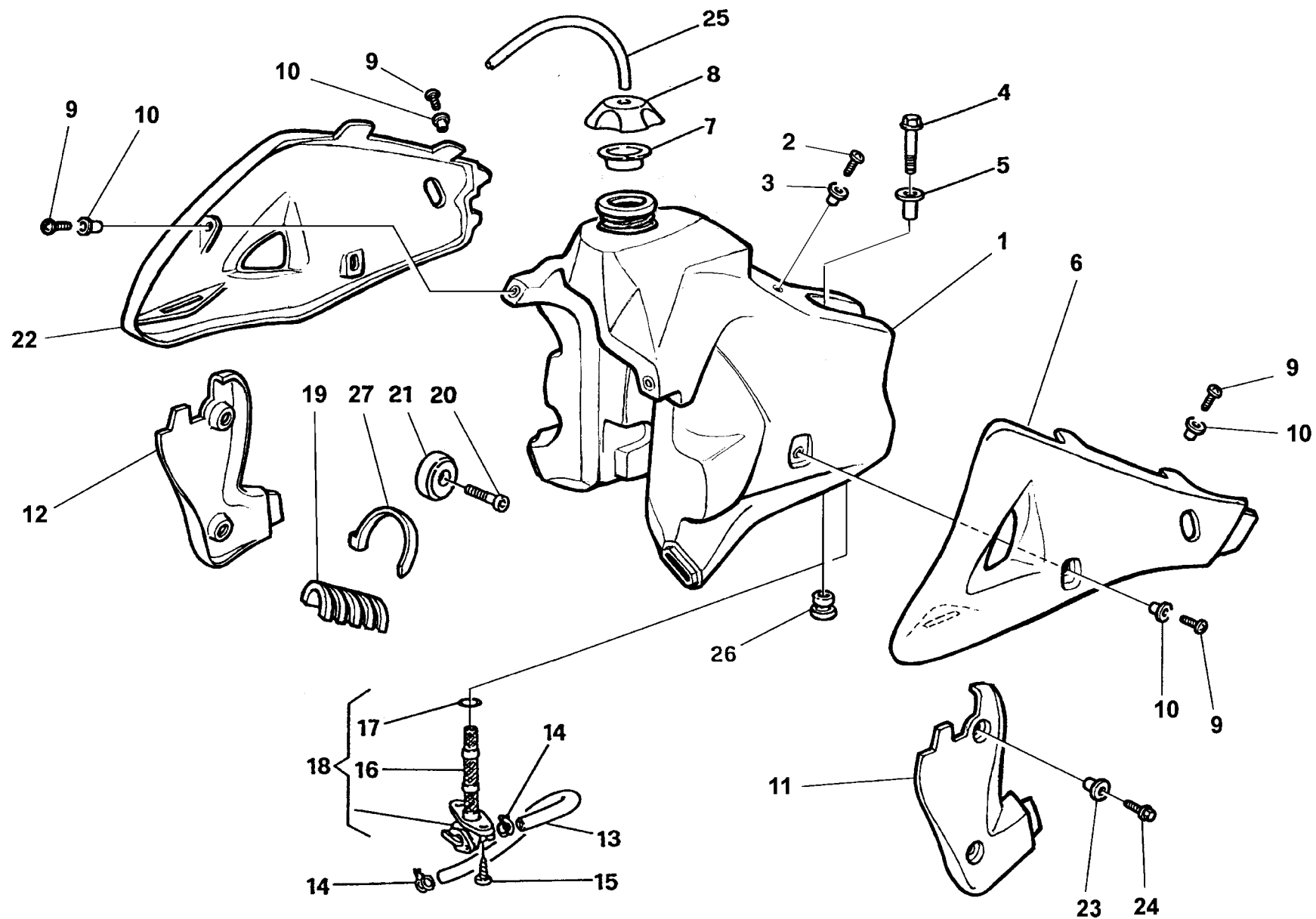



WR - CR 250/2001 ;
WR 360/2001

TAVOLA
DRAWING
TABLE
BILD
TABLA

20

SERBATOIO CARBURANTE, CONVOGLIATORI - GAS TANK, PANEL - RESERVOIR
CARBURANT, FLANC-KRAFTSTOFFBEHALTER, FLANKE-DEPOSITO GASOLINA, LATERAL

Note Notes Notas	Pos. No. N. Index Pos.	N. Cod. Code No. Nr. Code Code Nr N. Cod.	Q.tà Q.ty Q.te M.ge C.ad	DENOMINAZIONE	NAME	DESIGNATION	BESHREIBUNG	DENOMINACION	Validità Validity Validité Gültig Validez
W	1	8000 88862	1	Serbatoio carburante (I 11,2)	Fuel tank (I 11,2)	Réservoir essence (I 11,2)	Kraftstoffbehälter (I 11,2)	Depósito gasolina (I 11,2)	
C	1	80A0 88877	1	Serbatoio carburante (I 8,5)	Fuel tank (I 8,5)	Réservoir essence (I 8,5)	Kraftstoffbehälter (I 8,5)	Depósito gasolina (I 8,5)	
RC	1	8000 88862	1	Serbatoio carburante (I 11,2)	Fuel tank (I 11,2)	Réservoir essence (I 11,2)	Kraftstoffbehälter (I 11,2)	Depósito gasolina (I 11,2)	
	2	60N1 04134	1	Vite	Screw	Vis	Schraube	Tornillo	
	3	8000 66238	1	Distanziale	Spacer	Entretoise	Distanzstück	Separador	
	4	8A00 67545	1	Vite	Screw	Vis	Schraube	Tornillo	
	5	8000 69036	1	Distanziale	Spacer	Entretoise	Distanzstück	Separador	
	6	8000 88868	1	Convogliatore SX	L. side panel	Flanc G.	Flanke L.	Lateral I.	
	7	8000 56381	1	Guarnizione	Gasket	Garniture	Dichtung	Junta	
	8	8000 94098	1	Tappo	Plug	Bouchon	Verschluss	Tapón	
	9	8000 36467	8	Vite	Screw	Vis	Schraube	Tornillo	
	10	8000 45495	8	Bussola	Bushing	Douille	Buchse	Manguito	
	11	8000 93883	1	Protezione Sx	L.H. protection	Protection G.	Schutz Linke	Protección izquierda	
	12	8000 93017	1	Protezione Dx	R.H. protection	Protection D.	Schutz Rechte	Protección derecha	
	13	8000 94010	1	Condotto benzina	Pipe	Tuyau	Rohr	Tube	
	14	80A0 42349	2	Fascetta	Splitring	Anneau ressort	Sprengring	Anillo elástico	
	15	8000 37745	2	Vite	Screw	Vis	Schraube	Tornillo	
	16	8000 38748	1	Filtro benzina	Fuel filter	Filtre essence	Benzinfilter	Filtro gasolina	
	17	8000 01199	1	Anello OR	O-Ring	Bague OR	O-Ring	Anillo OR	
	18	8000 43592	1	Rubinetto completo	Cock assy	Robinet compl.	Kraftstoffahn, Kpl.	Llave de paso compl.	
	19	8000 94009	1	Tampone	Pad	Tampon	Stopfen	Tampón	
	20	8000 41240	2	Vite	Screw	Vis	Schraube	Tornillo	
	21	8000 40813	1	Tampone	Pad	Tampon	Stopfen	Tampón	
	22	8000 88869	1	Convogliatore DX	R. side panel	Flanc D.	Flanke R.	Lateral D.	
	23	8000 69429	4	Bussola	Bushing	Douille	Buchse	Manguito	
	24	8000 62727	4	Vite	Screw	Vis	Schraube	Tornillo	
	25	8B00 38752	1	Tubetto sfiato	Battery breather pipe	Event batterie	Batterieentlüfter	Tube de purga batería	
	26	8000 69035	1	Gommino	Rubber pad	Pièce caoutchouc	Gummstück	Junta de goma	
	27	8000 50005	1	Fascetta	Clamp	Collier	Schelle	Abrazadera	

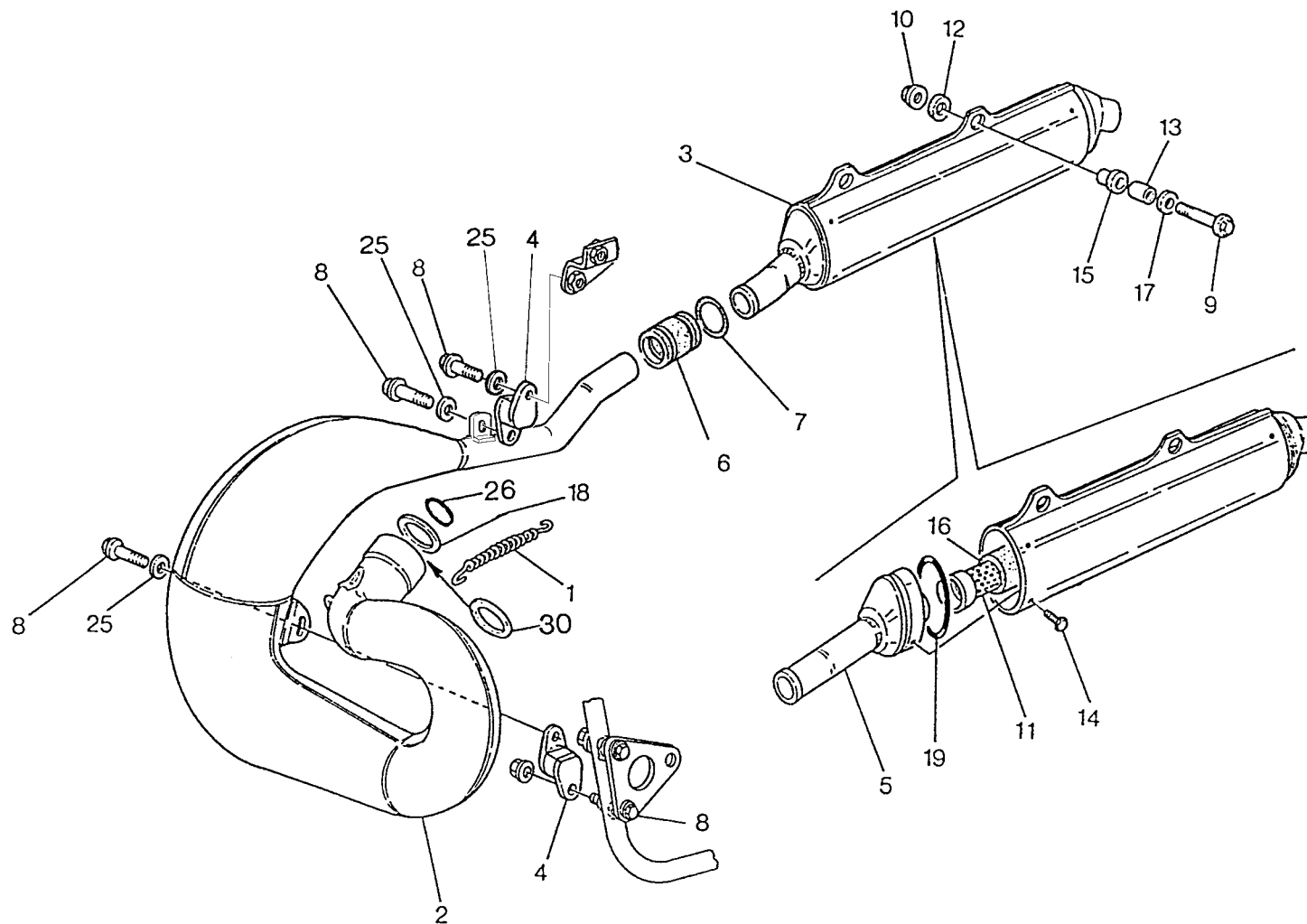



WR - CR 250/2001 ;
WR 360/2001

TAVOLA
DRAWING
TABLE
BILD
TABLA

21

SCARICO - EXHAUST SYSTEM
TUYAU D'ÉCHAPPEMENT - AUSPUFFROHR
TUBO DE ESCAPE

Note Notes Markte Notas	Pos. No. N. Index Pos.	N. Cod. Code No. Nr. Code Code Nr N. Cod.	Q.tà Q.ty Q.te M.ge C.ad	DENOMINAZIONE	NAME	DESIGNATION	BESHREIBUNG	DENOMINACION	Validità Validity Validité Gültig Validez
	1	8000 62341	2	Molla	Spring	Ressort	Feder	Resorte	
W	2	8000 97560	1	Tubo di scarico (250)	Exhaust pipe (250)	Tuyau d'échapp. (250)	Auspuffrohr (250)	Tubo de escape (250)	
U	2	8B00 97560	1	Tubo di scarico (250)	Exhaust pipe (250)	Tuyau d'échapp. (250)	Auspuffrohr (250)	Tubo de escape (250)	
C	2	8A00 97560	1	Tubo di scarico (250)	Exhaust pipe (250)	Tuyau d'échapp. (250)	Auspuffrohr (250)	Tubo de escape (250)	
W	2	8000 90027	1	Tubo di scarico (360)	Exhaust pipe (360)	Tuyau d'échapp. (360)	Auspuffrohr (360)	Tubo de escape (360)	
W	3	8000 93009	1	Silenziatore completo	Exhaust silencer	Silencieux d'échappement	Schalldämpfer	Silenciador de escape	
U	3	8000 90031	1	Silenziatore completo	Exhaust silencer	Silencieux d'échappement	Schalldämpfer	Silenciador de escape	
C	3	8000 93023	1	Silenziatore completo	Exhaust silencer	Silencieux d'échappement	Schalldämpfer	Silenciador de escape	
	4	8000 69113	2	Antivibrante	Silent-block	Antivibration	Schwingungsdämpfer	Anti-vibrador	
WY	5	8B00 88899	1	Fondello	Bottom	Fond	Bodenscheibe	Casquillo	
	6	8000 92788	1	Gommino	Rubber pad	Pièce caoutchouc	Gummistück	Junta de goma	
U	7	8000 66279	2	Molla	Spring	Ressort	Feder	Resorte	
	8	8000 62725	4	Vite	Screw	Vis	Schraube	Tornillo	
	9	8000 62730	2	Vite	Screw	Vis	Schraube	Tornillo	
	10	8000 44240	2	Dado	Nut	Ecrou	Mutter	Tuerca	
XY	11	8000 69231	1	Tubo forato	Pipe	Tuyau	Rohr	Tubo	
	12	1513 41401	2	Rosetta in gomma	Rubber washer	Rondella en caoutchouc	Gummischeibe	Roseta de goma	
	13	8C00 70379	2	Distanziale	Spacer	Entretoise	Distanzstück	Separador	
XY	14	60N4 01050	4	Vite	Screw	Vis	Schraube	Tornillo	
	15	1514 10702	2	Distanziale	Spacer	Entretoise	Distanzstück	Separador	
XY	16	8000 69232	1	Isolante (lana di roccia)	Insulation	Isolant	Isolierstoff	Aislante	
	17	1513 74301	2	Rosetta piana	Washer	Rondelle	Scheibe	Arandela	
XY	18	8A00 75329	1	Riduzione (360)	Reducer (360)	Reducteur (360)	Reduziereinsatz (360)	Reducción (360)	
XY	19	8A00 63842	1	Anello	Ring	Bague	Ring	Anillo	
	25	8000 45499	4	Rosetta	Washer	Rondella	Scheibe	Roseta	
	26	8A00 31970	1	Anello OR	O-Ring	Bague OR	O-Ring	Anillo OR	
	30	8A00 73541	1	Rondella	Washer	Rondella	Scheibe	Roseta	

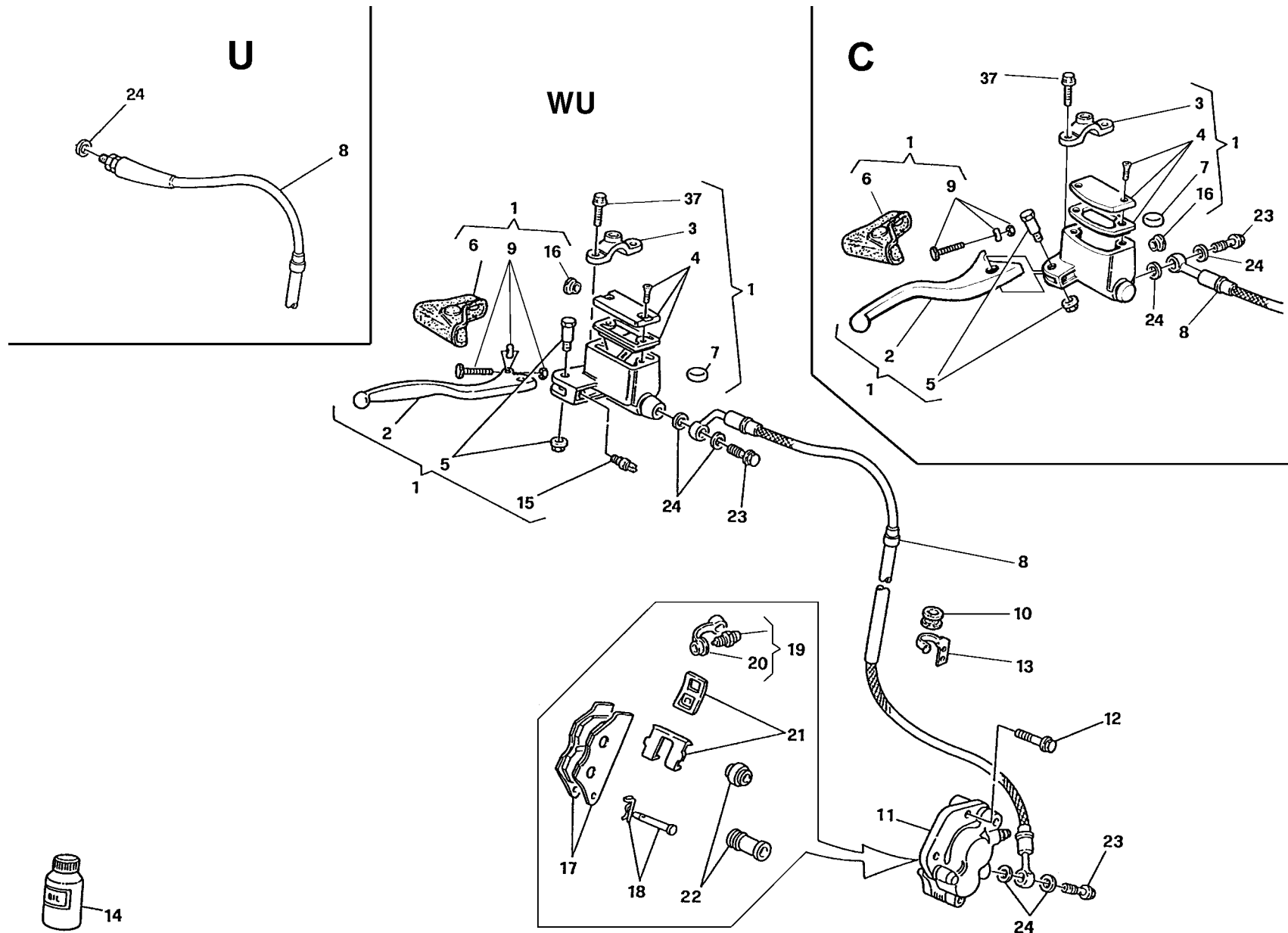



WR - CR 250/2001 ;
WR 360/2001

TAVOLA
DRAWING
TABLE
BILD
TABLA

22

FRENO IDRAULICO ANTERIORE - FRONTHYDRAULIC BRAKE
FREIN HYDRAULIQUE AVANT - VORTERBREMSE
FRENO HIDRAULICO DELANTERA

Note Notes Notas	Pos. No. Index Pos.	N. Cod. Code No. Nr. Code Code Nr	Q.tà Q.ty Q.te M.ge C.ad	DENOMINAZIONE	NAME	DESIGNATION	BESHREIBUNG	DENOMINACION	Validità Validity Validité Gültig Validez
W	1	8C00 77740	1	Pompa comando freno ant.	Brake pump	Pompe frein	Bremspumpe	Bomba freno	
CU	1	8000 93109	1	Pompa comando freno ant.	Brake pump	Pompe frein	Bremspumpe	Bomba freno	
W	2	8000 79096	1	Leva	Lever	Levier	Hebel	Palanca	
C	2	8000 94124	1	Leva	Lever	Levier	Hebel	Palanca	
W	3	8000 79097	1	Cavallotto	U-bolt	Cavalier	Bügelbolzen	Caballete	
C	3	8000 94125	1	Cavallotto	U-bolt	Cavalier	Bügelbolzen	Caballete	
W	4	8000 79069	1	Kit tappo	Plug kit	Bouchon kit	Verschluss Gruppe	Kit tapón	
C	4	8000 94126	1	Kit tappo	Plug kit	Bouchon kit	Verschluss Gruppe	Kit tapón	
W	5	8000 79070	1	Perno	Pin	Pivot	Bolzen	Perno	
C	5	8000 94127	1	Perno	Pin	Pivot	Bolzen	Perno	
W	6	8000 79098	4	Cappuccio	Cap	Capuchon	Kappe	Capuchon	
C	6	8000 94128	4	Cappuccio	Cap	Capuchon	Kappe	Capuchon	
	7	8000 79099	1	Antiemulsione	Antiemulsion	Antiemulsion	Eulsionwidriger	Antiemulsion	
W	8	8000 89915	1	Tubo mandata olio	Pipe	Tuyau	Rohr	Tubo	
CU	8	8000 93036	1	Tubo mandata olio	Pipe	Tuyau	Rohr	Tubo	
W	9	8000 79100	1	Regolazione	Regulator	Registre	Regler	Regulizador	
CU	9	8000 94129	1	Regolazione	Regulator	Registre	Regler	Regulizador	
	10	8000 71806	1	Occhiello passatubo	Fairlead	Passe-cable	Kabelführung	Prensa-cable	
	11	8000 85998	1	Pinza freno	Brake caliper	Etrier frein	Bremssattel	Pinza	
	12	8000 62733	2	Vite L=35mm	Screw L=35mm	Vis L=35mm	Schraube L=35mm	Tornillo L=35mm	
W	13	8000 90104	1	Piastrina di ritegno	Plate	Plaque	Platte	Placa	
UC	13	8000 72022	1	Piastrina di ritegno	Plate	Plaque	Platte	Placa	
R	14	8000 71445	1	Olio freni	Brake oil	Huile frein	Bremsöl	Aceite freni	
	15	8000 95248	1	Interruttore stop	Stop switch	Interrupteur stop	Stopschalter	Interruptor stop	
	16	8000 49654	1	Oblò	Inspection plug	Capuchon de inspection	Stopfen	Portilla	
	17	8A00 74181	1	Coppia pastiglie	Pads pair	Paire plaquettes	Bremsbelagpaar	Pareja pastillas	
	18	8000 85999	1	Perno	Pin	Pivot	Bolzen	Perno	
	19	8000 60404	1	Spurgo	Spurgo	Drain	Entleerung	Purga	
	20	8000 53259	1	Parapolvere	Boots	Para-poudre	Schutzhaube	Para-polvo	
	21	8000 79065	1	Molla-lamierino	Spring-steel clip	Ressort	Feder	Rresorte	
	22	8000 79066	1	Cuffie	Boots	Poussiers	haube	Gorro	

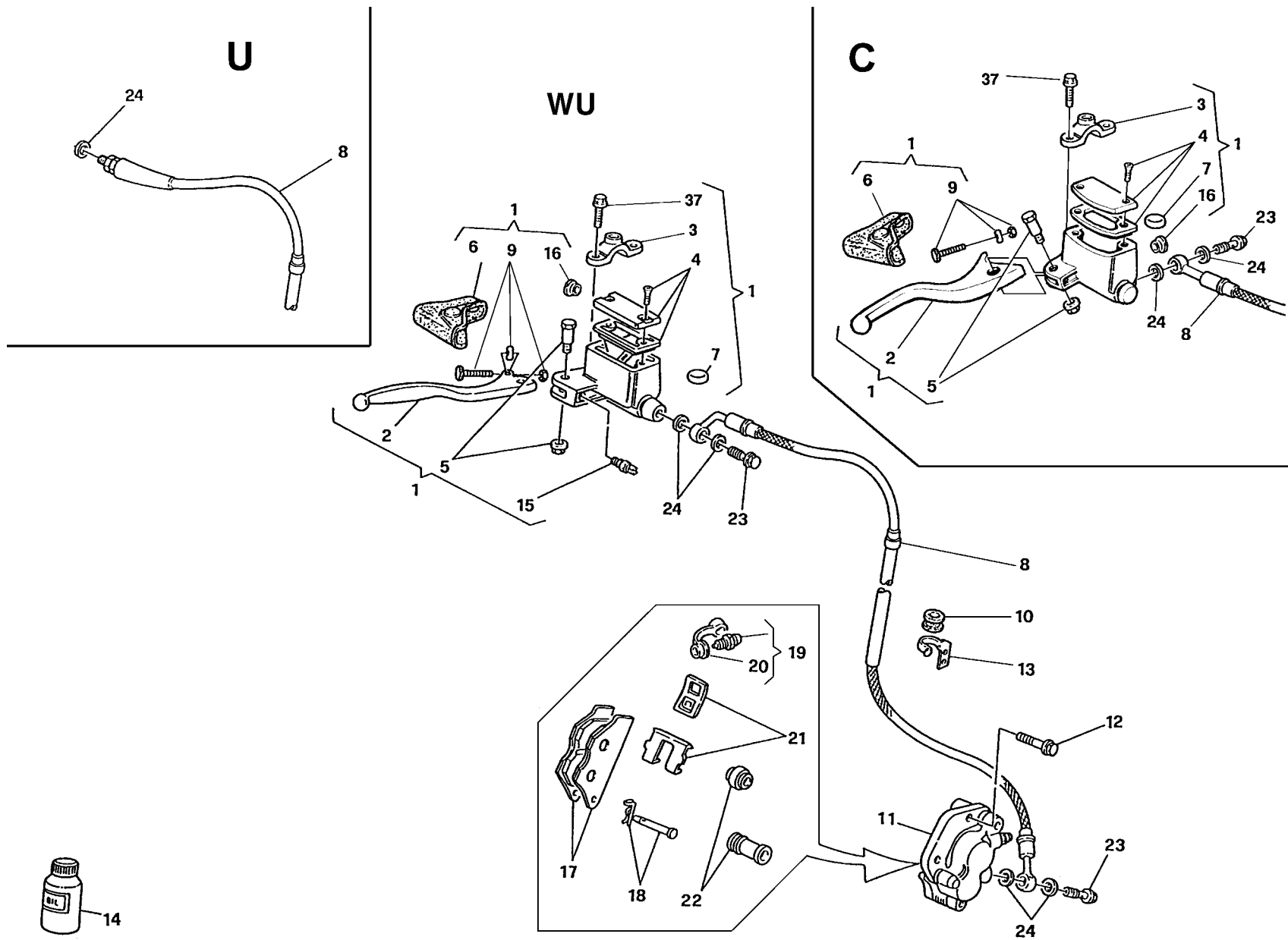

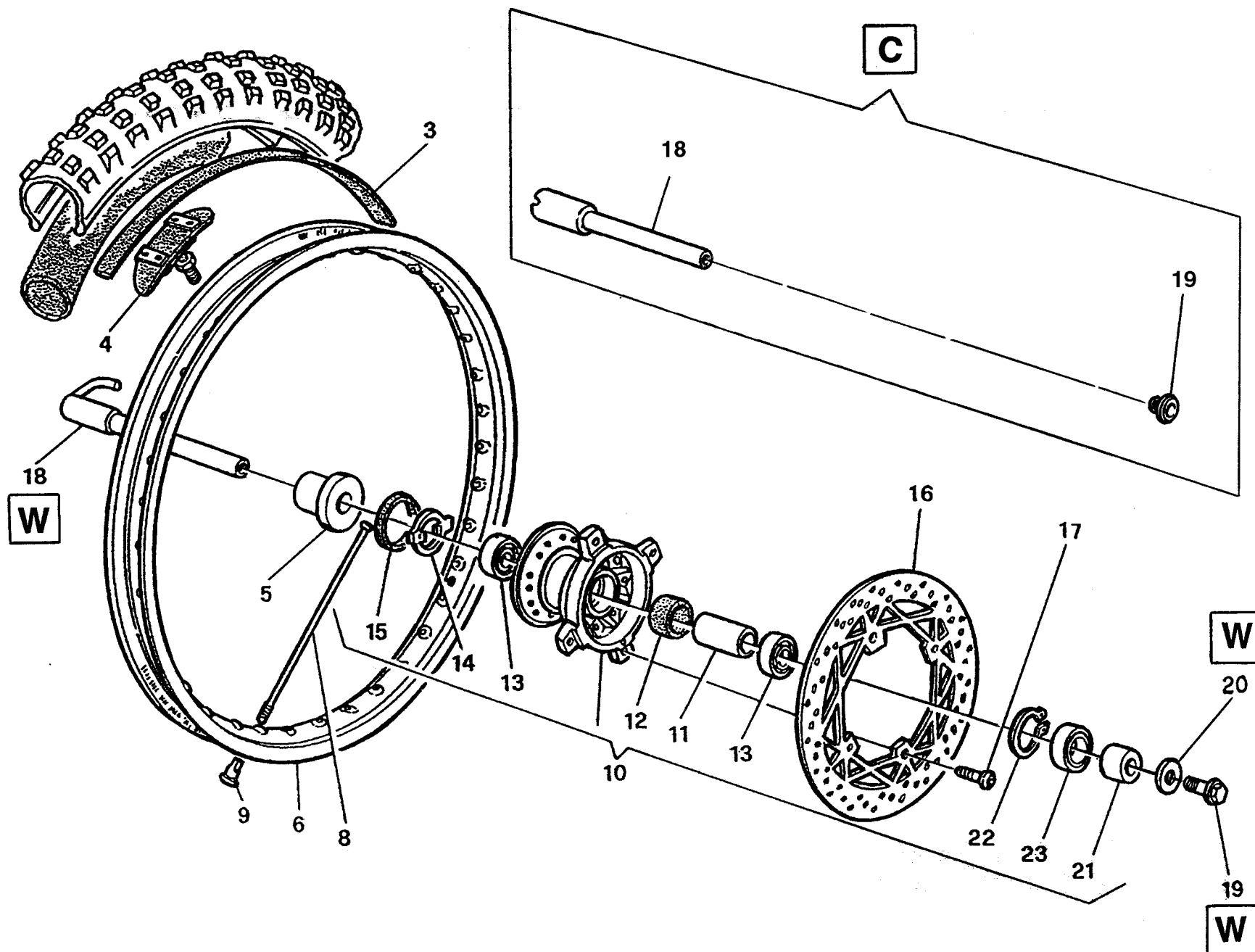



WR - CR 250/2001 ;
WR 360/2001

TAVOLA
DRAWING
TABLE
BILD
TABLA

22A

RUOTA ANTERIORE - FRONT WHEEL
ROUE AVANT - VORTERRAD
RUEDA DELANTERA

Note Notes Notas	Pos. No. Index	N. Cod. Code No. Nr. Code Code Nr	Q.tà Q.ty Q.te M.ge C.ad	DENOMINAZIONE	NAME	DESIGNATION	BESHREIBUNG	DENOMINACION	Validità Validity Validité Gültig Validez
	3	8000 13346	1	Fascia copriraggi	Rim strip	Bande	Band	Banda	
	4	8000 49036	1	Staffa fermacopertone	Bracket	Etrier	Buegel	Brida	
U	5	8000 77749	1	Distanziale	Spacer	Entretoise	Distanzstück	Separador	
	6	8000 53504	1	Cerchio (1,6x21")	Rim (1,6x21")	Jante (1,6x21")	Felge (1,6x21")	Llanta (1,6x21")	
	8	8000 92693	36	Raggio	Spoke	Bras	Speiche	Radio	
	9	69N4 29004	36	Nipplo	Nipple	Nipple	Nippel	Nipple	
W	10	8000 88882	1	Mozzo completo	Hub assy	Moyeau compl.	Radnabe, Kpl.	Cubo compl.	
C	10	8000 96838	1	Mozzo completo	Hub assy	Moyeau compl.	Radnabe, Kpl.	Cubo compl.	
W	11	8000 92790	1	Distanziale	Spacer	Entretoise	Distanzstück	Separador	
C	11	8000 96928	1	Distanziale	Spacer	Entretoise	Distanzstück	Separador	
	12	8000 92797	1	Portadistanziale	Spacer holder	Porte-entretoise	Abstandstuckhalter	Porta-distancial	
W	13	8000 39651	2	Cuscinetto a sfere(ø20xØ42x12 mm)	Ball bearing (ø20xØ42x12 mm)	Roulement à billes(ø20xØ42x12 mm)	Kugellager (ø20xØ42x12 mm)	Cojinete de bolas(ø20xØ42x12 mm)	
C	13	8000 84938	2	Cuscinetto a sfere(ø25xØ42x9 mm)	Ball bearing (ø25xØ42x9 mm)	Roulement à billes(ø25xØ42x9 mm)	Kugellager (ø25xØ42x9 mm)	Cojinete de bolas(ø25xØ42x9 mm)	
Y	14	8000 77884	1	Anello trascinatore	Ring	Bague	Ring	Anillo	
W	15	8000 51957	1	Anello di tenuta (ø40xØ50x4 mm)	Seal ring (ø40xØ50x4 mm)	Bague d'étanchéité (ø40xØ50x4 mm)	Dichtungsring (ø40xØ50x4 mm)	Anillo de retención (ø40xØ50x4 mm)	
C	15	8A00 92986	1	Anello di tenuta (ø28xØ50x5 mm)	Seal ring (ø28xØ50x5 mm)	Bague d'étanchéité (ø28xØ50x5 mm)	Dichtungsring (ø28xØ50x5 mm)	Anillo de retención (ø28xØ50x5 mm)	
	16	8000 88884	1	Disco freno (Ø260 mm)	Brake disc (Ø260 mm)	Disque frein (Ø260 mm)	Bremsscheibe (Ø260 mm)	Disco freno (Ø260 mm)	
	17	8A00 55241	4	Vite	Screw	Vis	Schraube	Tornillo	
W	18	8000 77699	1	Perno ruota	Pin	Pivot	Bolzen	Perno ruoda	
C	18	8000 96932	1	Perno ruota	Pin	Pivot	Bolzen	Perno ruoda	
W	19	8000 48773	1	Vite	Screw	Vis	Schraube	Tornillo	
C	19	8000 96933	1	Vite	Screw	Vis	Schraube	Tornillo	
W	20	8000 48772	1	Rosetta piana	Washer	Rondelle	Scheibe	Arandela	
W	21	8000 92792	1	Distanziale	Spacer	Entretoise	Distanzstück	Separador	
C	21	8000 96930	1	Distanziale	Spacer	Entretoise	Distanzstück	Separador	
	22	66N0 21270	1	Anello SEEGER	SEEGER ring	Anneau SEEGER	Ring SEEGER	Anillo SEEGER	
W	23	8000 88889	1	Anello di tenuta (ø32xØ42x7 mm)	Seal ring (ø32xØ42x7 mm)	Bague d'étanchéité (ø32xØ42x7 mm)	Dichtungsring (ø32xØ42x7 mm)	Anillo de retención (ø32xØ42x7 mm)	
C	23	8000 22966	1	Anello di tenuta (ø32xØ42x7 mm)	Seal ring (ø32xØ42x7 mm)	Bague d'étanchéité (ø32xØ42x7 mm)	Dichtungsring (ø32xØ42x7 mm)	Anillo de retención (ø32xØ42x7 mm)	

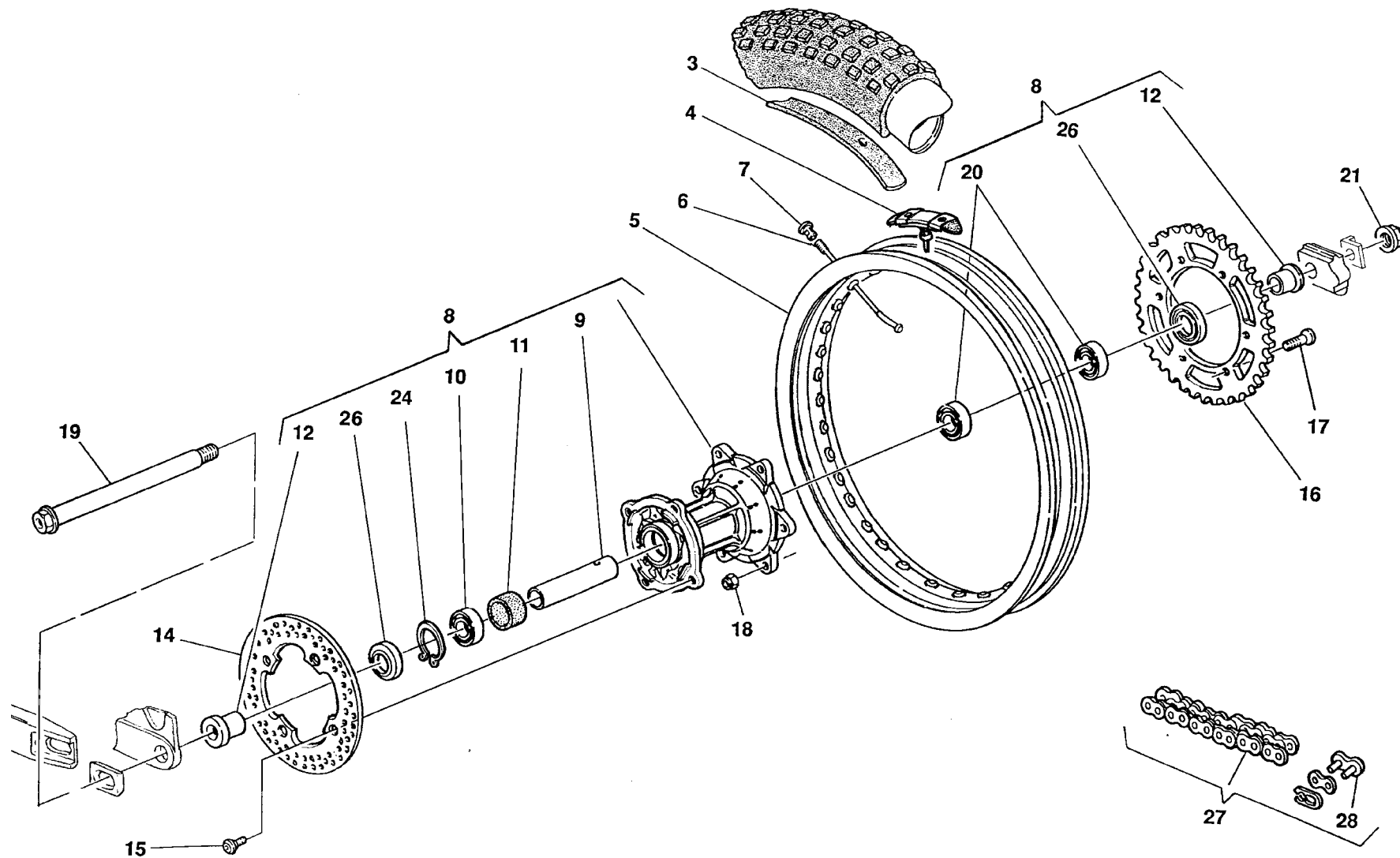



WR - CR 250/2001 ;
WR 360/2001

TAVOLA
DRAWING
TABLE
BILD
TABLA

23

RUOTA POSTERIORE - REAR WHEEL
ROUE ARRIERE - HINTERRAD
RUEDA TRASERA

Note Notes Notas	Pos. No. Index	N. Cod. Code No. Nr. Code Code Nr N. Cod.	Q.tà Q.ty Q.te M.ge C.ad	DENOMINAZIONE	NAME	DESIGNATION	BESHREIBUNG	DENOMINACION	Validità Validity Validité Gültig Validez
W	3	8000 01688	1	Fascia copriraggi	Rim strip	Bande	Band	Banda	
C	3	8000 10777	1	Fascia copriraggi	Rim strip	Bande	Band	Banda	
	4	8000 54073	1	Staffa fermacopertone	Bracket	Etrier	Buegel	Brida	
W	5	8000 55860	1	Cerchio (2,15 x 18")	Rim (2,15 x 18")	Jante (2,15 x 18")	Felge (2,15 x 18")	Llanta (2,15 x 18")	
C	5	8000 58929	1	Cerchio (2,15 x 19")	Rim (2,15 x 19")	Jante (2,15 x 19")	Felge (2,15 x 19")	Llanta (2,15 x 19")	
W	6	8000 92703	36	Raggio	Spoke	Bras	Speiche	Radio	
C	6	8000 90048	36	Raggio	Spoke	Bras	Speiche	Radio	
	7	69N4 29005	36	Nipplo	Nipple	Nipple	Nippel	Nipple	
	8	8000 96937	1	Mozzo completo	Hub assy	Moyeau compl.	Radnabe, Kpl.	Cubo compl.	
	9	8000 92414	1	Distanziale	Spacer	Entretoise	Distanzstück	Separador	
	10	8B00 26846	1	Cuscinetto (ø25xø47x16 mm)	Bearing (ø25xø47x16 mm)	Roulement (ø25xø47x16 mm)	Kugellager (ø25xø47x16 mm)	Cojinete (ø25xø47x16 mm)	
	11	8000 92797	1	Porta distanziale	Spacer	Entretoise	Distanzstück	Separador	
	12	8000 96938	2	Distanziale	Spacer	Entretoise	Distanzstück	Separador	
	14	8000 88887	1	Disco freno (Ø220 mm)	Brake disc (Ø220 mm)	Disque frein (Ø220 mm)	Bremsscheibe (Ø220 mm)	Disco freno (Ø220 mm)	
	15	8000 55878	4	Vite	Screw	Vis	Schraube	Tornillo	
S	16	8B00 96837	1	Corona (Z = 48)	Ring gear (Z = 48)	Couronne (Z = 48)	Kranz (Z = 48)	Corona (Z = 48)	
R	16	8A00 96837	1	Corona (Z = 47)	Ring gear (Z = 47)	Couronne (Z = 47)	Kranz (Z = 47)	Corona (Z = 47)	
R	16	8C00 96837	1	Corona (Z = 49)	Ring gear (Z = 49)	Couronne (Z = 49)	Kranz (Z = 49)	Corona (Z = 49)	
R	16	8D00 96837	1	Corona (Z = 50)	Ring gear (Z = 50)	Couronne (Z = 50)	Kranz (Z = 50)	Corona (Z = 50)	
	17	8B00 40796	6	Vite	Screw	Vis	Schraube	Tornillo	
	18	8000 43928	6	Dado	Nut	Ecrou	Mutter	Tuerca	
	19	8000 96940	1	Perno	Pin	Pivot	Bolzen	Perno	
	20	8A00 26846	2	Cuscinetto (ø25xø47x12 mm)	Bearing (ø25xø47x12 mm)	Roulement (ø25xø47x12 mm)	Kugellager (ø25xø47x12 mm)	Cojinete (ø25xø47x12 mm)	
	21	8000 93072	1	Dado	Nut	Ecrou	Mutter	Tuerca	
	24	66N0 21272	1	Anello SEEGER	SEEGER ring	Anneau SEEGER	Ring SEEGER	Anillo SEEGER	
	26	8000 89572	2	Anello di tenuta (ø32xø47x7 mm)	Seal ring (ø32xø47x7 mm)	Bague d'étanchéité (ø32xø47x7 mm)	Dichtungsring (ø32xø47x7 mm)	Anillo de retención (ø32xø47x7 mm)	
W	27	8A00 79783	1	Catena 5/8"x1/4"(112maglie)	Chain 5/8"x1/4"(112 link)	Chaîne 5/8"x1/4"(112maillon)	Kette 5/8"x1/4"(112Schake)	Cadena 5/8"x1/4"(112malla)	
WA	27	8000 65442	1	Catena 5/8"x1/4"(112maglie)	Chain 5/8"x1/4"(112 link)	Chaîne 5/8"x1/4"(112maillon)	Kette 5/8"x1/4"(112Schake)	Cadena 5/8"x1/4"(112malla)	
C	27	8A00 79785	1	Catena 5/8"x1/4"(112maglie)	Chain 5/8"x1/4"(112 link)	Chaîne 5/8"x1/4"(112maillon)	Kette 5/8"x1/4"(112Schake)	Cadena 5/8"x1/4"(112malla)	
CA	27	8A00 56768	1	Catena 5/8"x1/4"(112maglie)	Chain 5/8"x1/4"(112 link)	Chaîne 5/8"x1/4"(112maillon)	Kette 5/8"x1/4"(112Schake)	Cadena 5/8"x1/4"(112malla)	
W	28	8000 79789	1	Giunto	Master link	Joint	Kupplung	Junta	

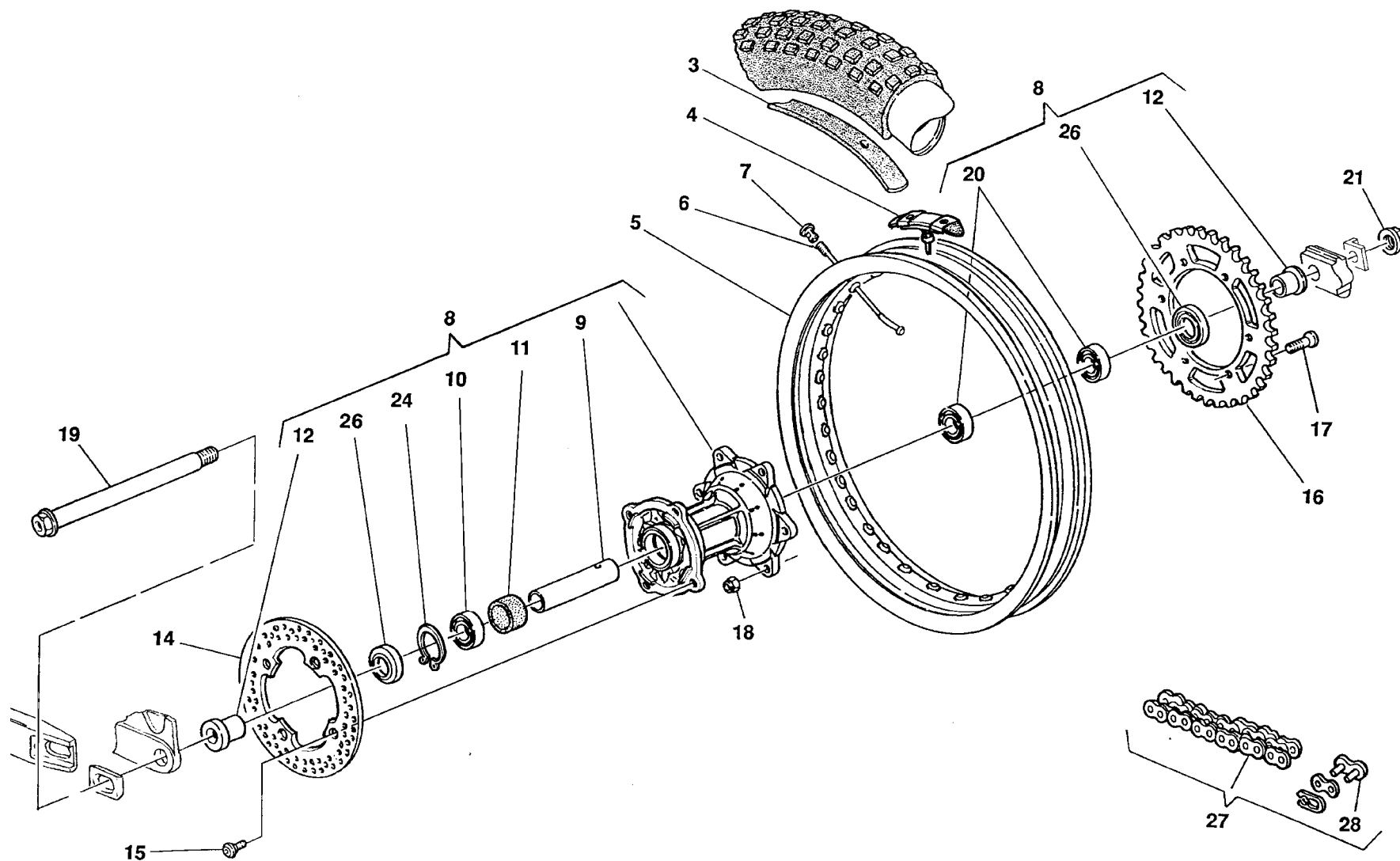

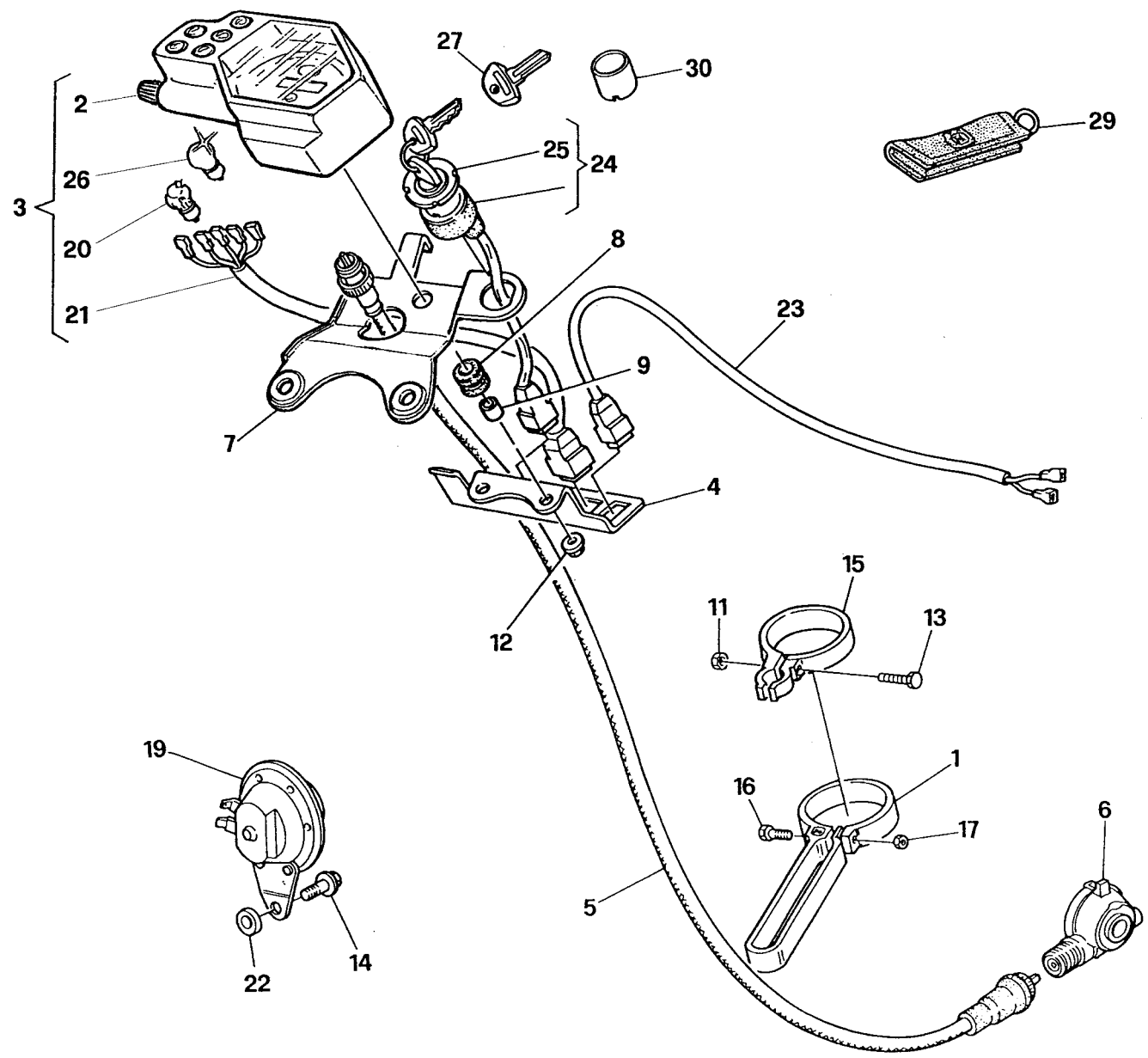

Note Notes Notas	Pos. No. Index	N. Cod. Code No. Nr. Code Code Nr N. Cod.	Q.tà Q.ty Q.te M.ge C.ad	DENOMINAZIONE	NAME	DESIGNATION	BESHREIBUNG	DENOMINACION	Validità Validity Validité Gültig Validez
XY	1	8AA0 65340	1	Fascetta	Clamp	Collier	Schelle	Banda	
XY	2	8000 87086	1	Contachilometri	Speedometer	Compteur-km	Tachometer	Cuenta-kilómetros	
XY	3	8000 87849	1	Ass. contachilometri	Speedometer assy	Compteur-km. compl.	Tachometer kpl.	Cuenta-kilómetros compl.	
XY	4	8000 69428	1	Piastra	Plate	Plaque	Platte	Placa	
XY	5	8C00 71759	1	Trasmissione contachilometri	Speedometer cable	Câble compteur - km	Tachokabel	Cable cuenta-kilómetros	
XY	6	8000 77827	1	Rinvio contachilometri	Odometer transm.	Renvoi compte-km.	Vorgelege Kilometerzähler	Reenvío cuenta-kilómetros	
XY	7	8000 87847	1	Piastra	Plate	Plaque	Platte	Placa	
XY	8	8000 62651	2	Antivibrante	Silent-block	Antivibration	Schwingungsdämpfer	Anti-vibrador	
XY	9	8000 25053	2	Distanziale	Spacer	Entretoise	Distanzstück	Separador	
XY	11	8000 56443	1	Dado	Nut	Ecrou	Mutter	Tuerca	
XY	12	8000 61313	2	Dado	Nut	Ecrou	Mutter	Tuerca	
XY	13	8B00 66525	1	Vite	Screw	Vis	Schraube	Tornillo	
XY	14	8000 62726	1	Vite	Screw	Vis	Schraube	Tornillo	
XY	15	80A0 70581	1	Fascetta	Clamp	Collier	Schelle	Banda	
XY	16	8B00 66525	1	Vite	Screw	Vis	Schraube	Tornillo	
XY	17	61N1 15192	1	Dado	Nut	Ecrou	Mutter	Tuerca	
XY	19	8000 90107	1	Avvisatore acustico	Horn	Signal acoustique	Hupe	Avisador acústico	
XY	20	8000 20602	5	Lampadina (12V-1,2W)	Lamp (12V-1,2W)	Lampe (12V-1,2W)	Lampe (12V-1,2W)	Lamparilla (12V-1,2W)	
XY	21	8000 87088	1	Cavi	Cable	Cable	Kabel	Cable	
XY	22	8000 60969	1	Rosetta	Washer	Rondelle	Scheibe	Arandela	
XY	23	8000 75477	1	Cablaggio interruttore stop	Stop switch cable	Cable	Kabel	Cable	
XY	24	8000 74259	1	Interr. accensione completo	Ignition switch assy	Interrupteur pour allum. comp.	Schalter, Kpl.	Interruptor encendido compl.	
XY	25	8000 74258	1	Ghiera	Ring nut	Embout	Nutmutter	Virola	
XY	26	8000 60033	2	Lampadina (12V-2W)	Lamp (12V-2W)	Lampe (12V-2W)	Lampe (12V-2W)	Lamparilla (12V-2W)	
XY	27	8000 38210	1	Chiave grezza	Raw kei	Cléf primitive	Schlüssel	Llave greggia	
XD	29	8000 97615	1	Porta chiavi	Key-ring	Porte-clefs	Schlüsselring	Llavero	
XY	30	8000 50569	1	Distanziale	Spacer	Entretoise	Distanzstück	Separador	

Note Notes Marka Notas	Pos. No. Index Pos.	N. Cod. Code No. Nr. Code Code Nr N. Cod.	Q.tà Q.ty Q.te M.ge C.ad	DENOMINAZIONE	NAME	DESIGNATION	BESHREIBUNG	DENOMINACION	Validità Validity Validité Gültig Validez
X	1	8A00 20373	2	Rosetta piana	Washer	Rondelle	Scheibe	Arandela	
X	2	8000 91957	1	Gruppo principale cavi	Cable assy	Cables compl.	Kabel Kpl.	Grupo principal cables	
X	3	8000 70277	1	Cavo posteriore	Cable	Cable	Kabel	Cable	
X	4	8000 72494	1	Passacavo	Fairlead	Passe-câble	Kabelführung	Prensa-cable	
X	6	8000 42946	1	Lampada (12V-55/60W)	Lamp (12V-55/60W)	Lampe (12V-55/60W)	Lampe (12V-55/60W)	Lamparilla (12V-55/60W)	
X	8	8000 62728	2	Vite	Screw	Vis	Schraube	Tornillo	
X	9	8000 36230	1	Lampada (12V-5W)	Lamp (12V-5W)	Lampe (12V-5W)	Lampe (12V-5W)	Lamparilla (12V-5W)	
X	10	8B00 69429	2	Bussola	Bush	Douille	Buchse	Manguito	
X	11	8000 88873	1	Fanale posteriore completo	Tail light	Feux arrière	Hinterleuchte	Faro trasero	
X	12	8000 94119	1	Lente	Lens	Loupe	Linse	Lente	
X	13	8000 18246	1	Lampada (12V-5/12W)	Lamp (12V-5/12W)	Lampe (12V-5/12W)	Lampe (12V-5/12W)	Lamparilla (12V-5/12W)	
X	14	60N4 95615	2	Vite	Screw	Vis	Schraube	Tornillo	
X	15	8000 94121	1	Cablaggio	Cable	Cable	Kabel	Cable	
X	16	8000 94120	2	Distanziale	Spacer	Entretoise	Distanzstück	Separador	
X	17	8000 18048	2	Gommino	Rubber pad	Pièce caoutchouc	Gummistück	Junta de goma	
X	18	8000 44240	2	Dado	Nut	Ecrou	Mutter	Tuerca	
X	19	8000 62730	2	Vite	Screw	Vis	Schraube	Tornillo	
X	20	8000 50808	2	Gommino	Rubber pad	Pièce caoutchouc	Gummistück	Junta de goma	
X	22	8000 87562	1	Gruppo ottico completo	Optical group	Groupe optique	Optische Gruppe	Grupo óptico	
AX	22A	8000 70280	1	Gruppo ottico completo	Optical group	Groupe optique	Optische Gruppe	Grupo óptico	
X	22	8000 90197	1	Gruppo ottico compl. (AUS-GB-J)	Optical group (AUS-GB-J)	Groupe optique (AUS-GB-J)	Optische Gruppe (AUS-GB-J)	Grupo óptico (AUS-GB-J)	
X	23	8D00 70034	2	Distanziale	Spacer	Entretoise	Distanzstück	Separador	
X	24	8000 95649	1	Cuffia in gomma	Boot	Poussière	Gummihäube	Gorro de protección en goma	
X	24A	8000 70282	1	Cuffia in gomma	Boot	Poussière	Gummihäube	Gorro de protección en goma	
X	25	80C0 87060	1	Cupolino	Fairing	Carenage	Verkleidung	Cúpula	
	26	8000 75348	1	Regolatore di tensione	Voltage rectifier	Régulateur de tension	Spannungsregler	Regulador de tensión	
X	27	8000 95648	1	Molla	Spring	Ressort	Feder	Resorte	

Note Notes Mark Notas	Pos. No. Index Pos.	N. Cod. Code No. Nr. Code Code Nr N. Cod.	Q.tà Q.ty Q.te M.ge C.ad	DENOMINAZIONE	NAME	DESIGNATION	BESHREIBUNG	DENOMINACION	Validità Validity Validité Gültig Validez
X	27A	8000 42926	1	Portalampada	Lamp holder	Douille	Lampenfassung	Porta-lamparilla	
X	28	8000 88139	1	Guarnizione	Gasket	Garniture	Dichtung	Junta	
X	29	8000 56444	8	Fascetta (L=188 mm)	Clamp (L=188 mm)	Collier (L=188 mm)	Schelle (L=188 mm)	Banda (L=188 mm)	
X	30	8000 94595	1	Portatarga	Licence plate holder	Portebalai	Schildträger	Portamatrícula	
X	31	8000 62727	2	Vite	Screw	Vis	Schraube	Tornillo	
X	32	8000 56359	2	Rosetta	Washer	Rondelle	Scheibe	Arandela	
X	33	8000 58207	1	Passacavo	Fairlead	Passe-câble	Kabelführung	Prensa-cable	
X	34	8000 40718	2	Dado	Nut	Ecrou	Mutter	Tuerca	
X	35	8000 73834	1	Catadiottro	Reflector	Catadioptrique	Ruckstrahler	Catafaros	
	36	8000 62729	1	Vite	Screw	Vis	Schraube	Tornillo	
X	37	8000 94342	1	Paraspruzzi (A-CH-D)	Rear end (A-CH-D)	Terminal (A-CH-D)	Hinterkiff (A-CH-D)	Para rociada (A-CH-D)	
X	42	8000 75549	1	Cavo arresto motore	Cable for engine stop	Câble d'arrêt moteur	Kabel motoranhalten	Cable parada motor	
X	43	8000 40717	2	Dado	Nut	Ecrou	Mutter	Tuerca	
X	44	62N1 15547	2	Rosetta	Washer	Rondelle	Scheibe	Arandela	
X	45	8000 68690	1	Fascetta	Clamp	Collier	Schelle	Banda	
X	46	8000 62725	1	Vite	Screw	Vis	Schraube	Tornillo	
X	48	8000 95650	2	Fascetta	Clamp	Collier	Schelle	Banda	
X	50	8AA0 55705	2	Linguetta fermacavo	Retainer	Arret	Klammer	Abrazadera de sujeción	

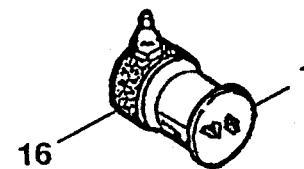
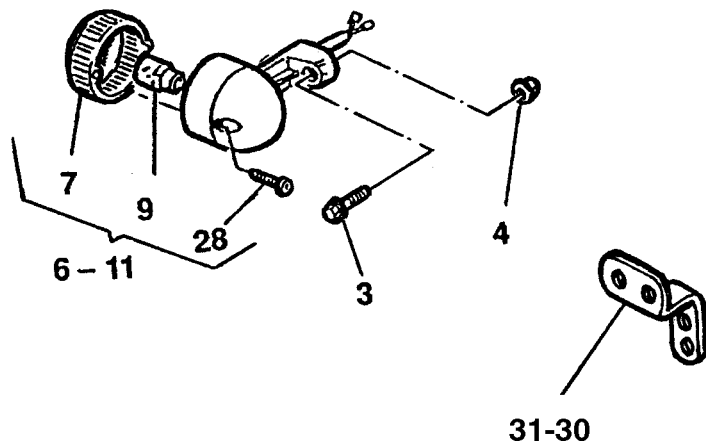
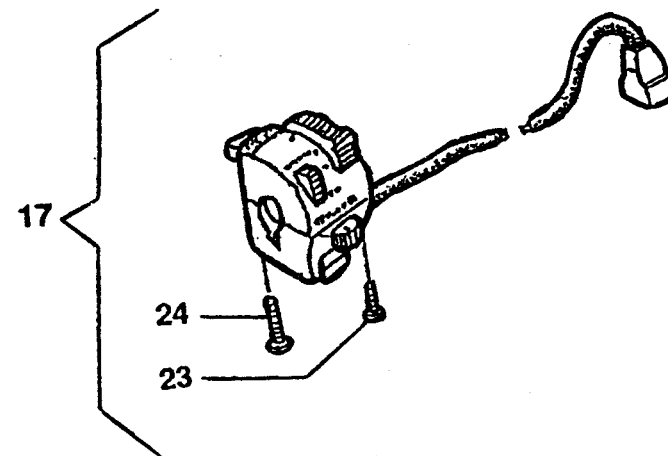
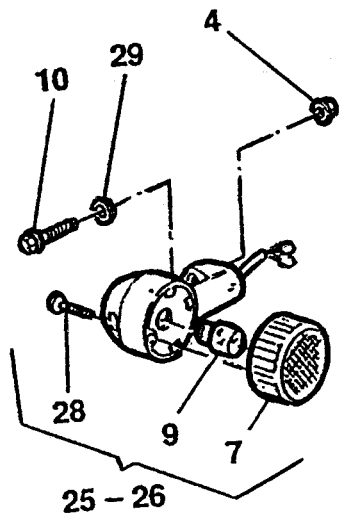

Note Notes Notas	Pos. No. Index Pos.	N. Cod. Code No. Nr. Code Code Nr N. Cod.	Q.tà Q.ty Q.te M.ge C.ad	DENOMINAZIONE	NAME	DESIGNATION	BESHREIBUNG	DENOMINACION	Validità Validity Validité Gültig Validez
DX	1	8000 57511	1	Intermittenza	Flash device	Intermittence	Blinkgeber	ntermitencia	
DX	3	8000 62728	2	Vite anteriore (M6x20 mm)	Front screw (M6x20 mm)	Vis avant (M6x20 mm)	Vord. Schraube (M6x20 mm)	Tornillo delantero (M6x 20 mm)	
DX	4	8000 44240	4	Dado	Nut	Ecrou	Mutter	Tuerca	
DX	6	8000 88336	1	Indicatore anteriore DX	Blinker R	Clignotant D	Blinker R	ntermitente D	
DX	7	8000 73591	4	Lente	Lens	Loupe	Linse	Lente	
DX	9	8000 36726	4	Lampada (12V - 10W)	Lamp (12V - 10W)	Lampe (12V - 10W)	Lampe (12V - 10W)	Lamparilla (12V - 10W)	
DX	10	8000 62728	2	Vite	Screw	Vis	Schraube	Tornillo	
DX	11	8000 88337	1	Indicatore anteriore SX	Blinker L	Clignotant G	Blinker L	ntermitente I	
DX	16	8000 37599	1	Supporto elastico	Support	Support	Halterung	Soporte	
X	17	8000 89919	1	Commutatore compl.	Switch compl.	Commutateur compl.	Kombischalter kpl.	Conmutador compl.	
XA	17	8000 89920	1	Commutatore compl.	Switch compl.	Commutateur compl.	Kombischalter kpl.	Conmutador compl.	
	17	8000 92149	1	Commutatore compl. (J)	Switch compl. (J)	Commutateur compl. (J)	Kombischalter kpl. (J)	Conmutador compl. (J)	
DX	25	8000 88334	1	Indicatore posteriore DX	Blinker R	Clignotant D	Blinker R	ntermitente D	
DX	26	8000 88335	1	Indicatore posteriore SX	Blinker L	Clignotant G	Blinker L	ntermitente I	
	27	8000 71578	2	Fascetta	Clamp	Collier	Schelle	Banda	
DX	28	8000 73592	4	Vite	Screw	Vis	Schraube	Tornillo	
DX	29	8000 56359	2	Rosetta	Washer	Rondelle	Scheibe	Roseta	
DX	30	8000 93011	1	Piastrina DX	R.H.Plate	Plaque D.	R. Platte	Placa D.	
DX	31	8A00 93011	1	Piastrina SX	L.H.Plate	Plaque G.	L. Platte	Placa I.	

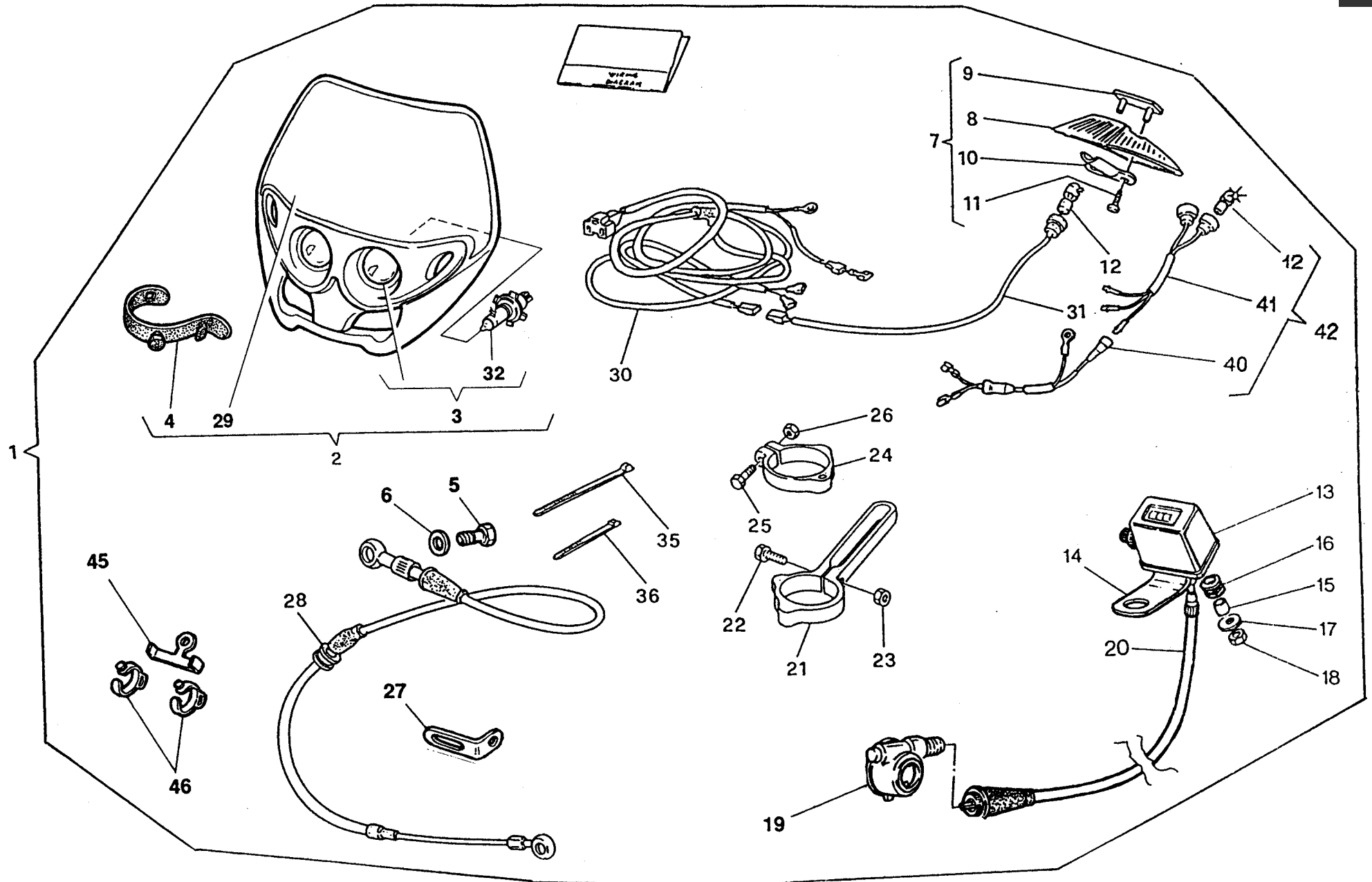



WR 250-360
USA/2001

TAVOLA
DRAWING
TABLE
BILD
TABLA

27

KIT TRASFORMAZIONE ENDURO - ENDURO TRANSFORMATION KIT
KIT DE TRANSFORMATION ENDURO - KIT TRANSFORMATION ENDURO
KIT DE TRANSFORMACIÒN ENDURO

Note Notes Notas	Pos. No. N. Index Pos.	N. Cod. Code No. Nr. Code Code Nr	Q.tà Q.ty Q.te M.ge C.ad	DENOMINAZIONE	NAME	DESIGNATION	BESHREIBUNG	DENOMINACION	Validità Validity Validité Gültig Validez
	1	8000 97819	1	Kit ENDURO	ENDURO Kit	Groupe ENDURO	Gruppe ENDURO	Kit ENDURO	
	2	8000 88538	1	Cupolino	Fairing	Carenage	Verkleidung	Cúpula	
	3	8000 88603	1	Gruppo ottico destro	R.H. Optical group	Groupe optique droite	R. Optische Gruppe	Grupo óptico derecho	
	3	8A00 88603	1	Gruppo ottico sinistro	L.H. Optical group	Groupe optique gauche	L. Optische Gruppe	Grupo óptico izquierdo	
	4	8000 88602	4	Elastico	Elastic	Elastique	Elastisch	Elástico	
	5	8000 57155	1	Vite	Screw	Vis	Schraube	Tornillo	
	6	8000 21480	1	Rosetta	Washer	Rondelle	Scheibe	Arandela	
	7	8000 71213	1	Fanale posteriore completo	Tail light group	Groupe feux arrière	Hinterleuchte Gruppe	Grupo faro trasero	
	8	8000 71214	1	Fanale posteriore	Tail light	Feux arrière	Hinterleuchte	Faro trasero	
	9	8000 71215	1	Fascetta	Clamp	Collier	Schelle	Banda	
	10	8000 71216	1	Protezione	Guard	Protection	Schutz	Protección	
	11	8000 71217	2	Vite	Screw	Vis	Schraube	Tornillo	
	12	8000 26694	2	Lampadina 12V-3W	Lamp 12V-3W	Lampe 12V-3W	Lampe 12V-3W	Lamparilla 12V-3W	
	13	1517 54001	1	Contamiglia	Odometer	Compte-mille	Tachometer	Cuentamiglias	
	14	8000 80262	1	Piastra	Plate	Plaque	Platte	Placa	
	15	8000 41863	2	Distanziale	Spacer	Entretoise	Distanzstück	Separador	
	16	8000 41862	2	Gommino	Rubber pad	Pièce caoutchouc	Gummstück	Junta de goma	
	17	62N1 15548	2	Rosetta	Washer	Rondelle	Scheibe	Arandela	
	18	61N1 15191	2	Dado	Nut	Ecrou	Mutter	Tuerca	
	19	8000 77827	1	Rinvio contamiglia	Odometer transm.	Renvoi compte-km.	Vorgelege Kilometerzähler	Reenvío cuenta-kilómetros	
	20	8B00 71759	1	Trasmissione contachilometri	Odometer cable	Câble compteur - km	Tachokabel	Cable cuenta-kilómetros	
	21	8AA0 65340	1	Fascetta	Clamp	Collier	Schelle	Banda	
	22	8B00 66525	1	Vite	Screw	Vis	Schraube	Tornillo	
	23	61N1 15192	1	Dado	Nut	Ecrou	Mutter	Tuerca	
	24	80A0 70581	1	Fascetta	Clamp	Collier	Schelle	Banda	
	25	8B00 66525	1	Vite	Screw	Vis	Schraube	Tornillo	
	26	8000 56443	1	Dado	Nut	Ecrou	Mutter	Tuerca	
	27	8AA0 55705	1	Linguetta fermacavo	Retainer	Arret	Klammer	Abrazadera de sujeción	
	28	8000 89915	1	Tubo	Pipe	Tuyau	Rohr	Tubo	
	29	8000 91839	1	Decal portafaro	Transfer	Decalcomania	Abziehbild	Calcomania	
	30	8000 91964	1	Gruppo principale cavi	Kit cable assy	Groupe cables compl.	Kabelgruppe Kpl.	Grupo principal cables	
	31	8000 71221	1	Gruppo cavi	Cable assy	Cables compl.	Kabel Kpl.	Grupo cables	

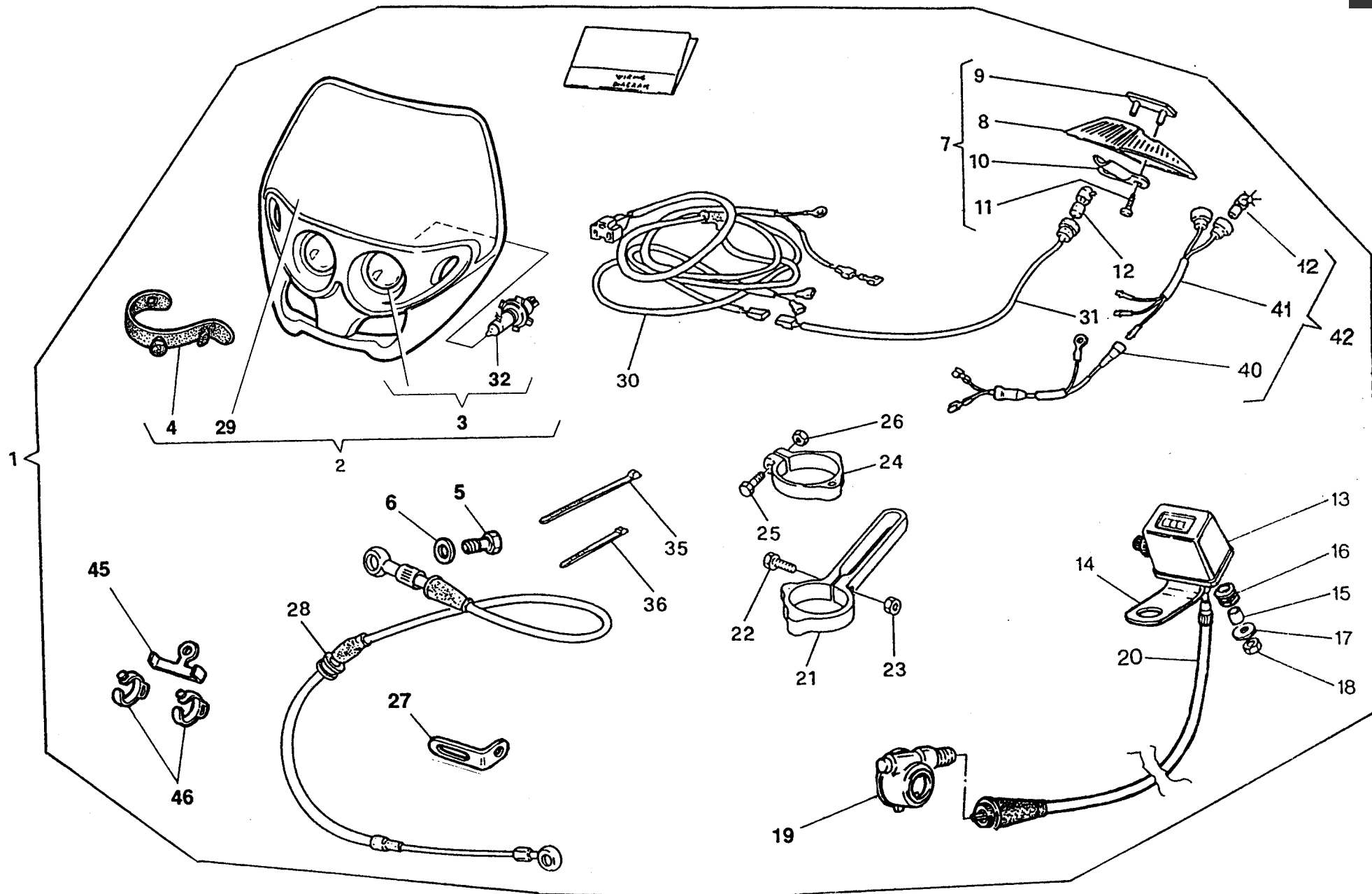

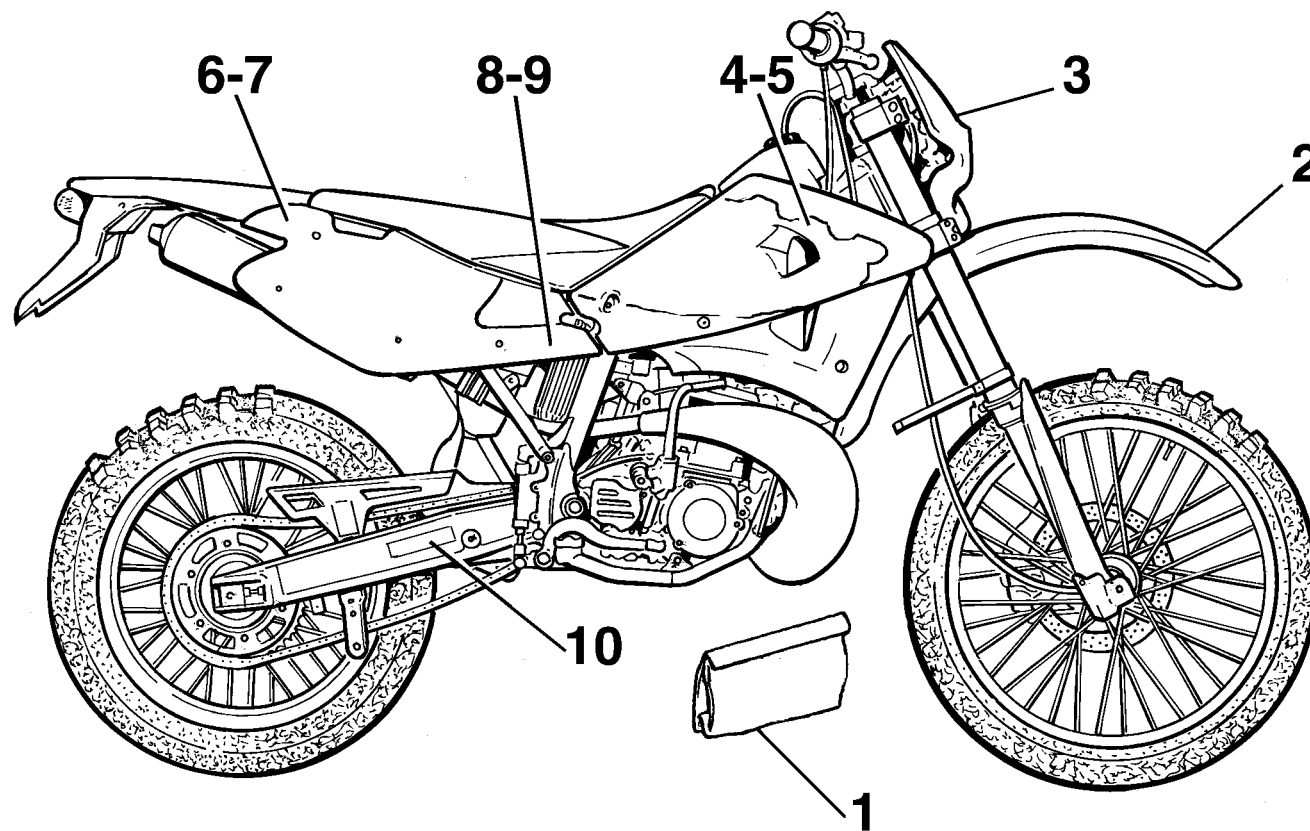

Note Notes Notas	Pos. No. Index Pos.	N. Cod. Code No. Nr. Code Code Nr N. Cod.	Q.tà Q.ty Q.te M.ge C.ad	DENOMINAZIONE	NAME	DESIGNATION	BESHREIBUNG	DENOMINACION	Validità Validity Validité Gültig Validez
	1	8000 97153	1	Kit adesivi (250)	Trims kit (250)	Gr. décal. (250)	Hinterabziehbild Gruppe (250)	Kit adhesivo (250)	
	1	8000 97155	1	Kit adesivi (360)	Trims kit (360)	Gr. décal. (360)	Hinterabziehbild Gruppe (360)	Kit adhesivo (360)	
	2	8000 97856	1	Decal per parafrangente anteriore	Transfer	Decalcomania	Abziehbild	Calcomania	
	3	8000 97857	1	Decal per parafrangente posteriore	Transfer	Decalcomania	Abziehbild	Calcomania	
	4	8000 97858	1	Decal per convogliatore Dx	R.H. transfer	Decalcomania D.	Abziehbild R.	Calcomania der.	
	5	8000 97859	1	Decal per convogliatore Sx	L.H. transfer	Decalcomania G.	Abziehbild L.	Calcomania iz.	
	6	80A0 94222	1	Decal per fianchetto Dx	R.H. transfer	Decalcomania D.	Abziehbild R.	Calcomania der.	
	7	80A0 94221	1	Decal per fianchetto Sx	L.H. transfer	Decalcomania G.	Abziehbild L.	Calcomania iz.	
	8	8000 94240	1	Decal per fianchetto Dx	R.H. transfer	Decalcomania D.	Abziehbild R.	Calcomania der.	
	9	8000 94239	1	Decal per fianchetto Sx	L.H. transfer	Decalcomania G.	Abziehbild L.	Calcomania iz.	
	10	80D0 96951	2	Decal per forcellone (250)	Fork transfer (250)	Decalcomania (250)	Abziehbild (250)	Calcomania (250)	
	10	80F0 96951	2	Decal per forcellone (360)	Fork transfer (360)	Decalcomania (360)	Abziehbild (360)	Calcomania (360)	

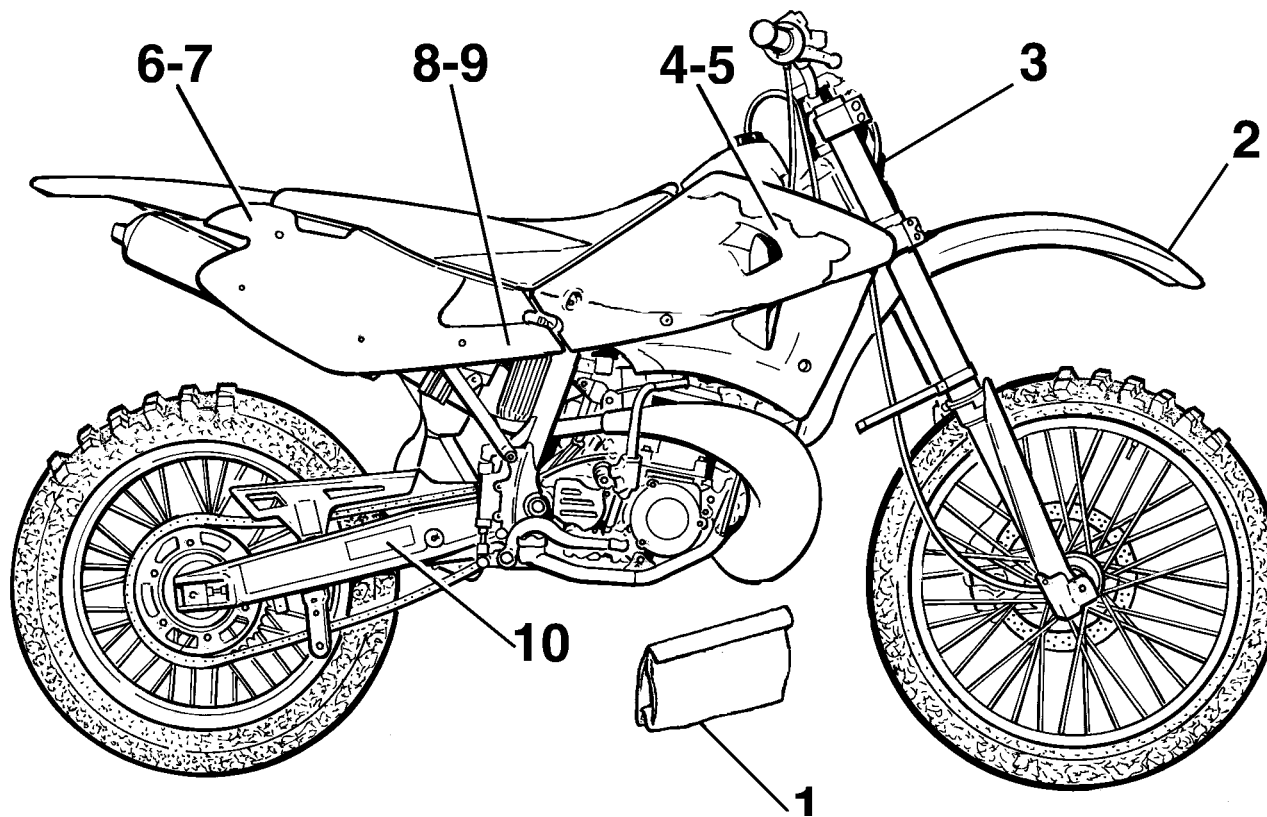



CR 250/2001 ; WR 250
- 360 USA/2001

TAVOLA
DRAWING
TABLE
BILD
TABLA

29

DECALCOMANIE - TRANSFER
DACALCOMANIE - ABZIEHBILD
CALCOMANIA

Note Notes Marken Notas	Pos. No. Index Pos.	N. Cod. Code No. Nr. Code Code Nr N. Cod.	Q.tà Q.ty Q.te M.ge C.ad	DENOMINAZIONE	NAME	DESIGNATION	BESHREIBUNG	DENOMINACION	Validità Validity Validité Gültig Validez
U	1	8000 97153	1	Kit adesivi (250)	Trims kit (250)	Gr. décal. (250)	Hinterabziehbild Gruppe (250)	Kit adhesivo (250)	
U	1	8000 97155	1	Kit adesivi (360)	Trims kit (360)	Gr. décal. (360)	Hinterabziehbild Gruppe (360)	Kit adhesivo (360)	
C	1	8000 97039	1	Kit adesivi	Trims kit	Gr. décal.	Hinterabziehbild Gruppe	Kit adhesivo	
	2	8000 97856	1	Decal per parafango anteriore	Transfer	Decalcomania	Abziehbild	Calcomania	
	3	8000 94213	1	Decal per portanumero	Transfer	Decalcomania	Abziehbild	Calcomania	
	4	8000 97858	1	Decal per convogliatore Dx	R.H. transfer	Decalcomania D.	Abziehbild R.	Calcomania der.	
	5	8000 97859	1	Decal per convogliatore Sx	L.H. transfer	Decalcomania G.	Abziehbild L.	Calcomania iz.	
	6	80A0 94222	1	Decal per fianchetto Dx	R.H. transfer	Decalcomania D.	Abziehbild R.	Calcomania der.	
	7	80A0 94221	1	Decal per fianchetto Sx	L.H. transfer	Decalcomania G.	Abziehbild L.	Calcomania iz.	
	8	8000 94240	1	Decal per fianchetto Dx	R.H. transfer	Decalcomania D.	Abziehbild R.	Calcomania der.	
	9	8000 94239	1	Decal per fianchetto Sx	L.H. transfer	Decalcomania G.	Abziehbild L.	Calcomania iz.	
U	10	80D0 96951	2	Decal per forcellone (250)	Fork transfer (250)	Decalcomania (250)	Abziehbild (250)	Calcomania (250)	
U	10	80F0 96951	2	Decal per forcellone (360)	Fork transfer (360)	Decalcomania (360)	Abziehbild (360)	Calcomania (360)	
C	10	80E0 96951	2	Decal per forcellone	Fork transfer	Decalcomania	Abziehbild	Calcomania	

DISEGNO DRAWING DESSIN ZEICHNUNG DIBUJO	TAVOLA DRAWING TABLE BILD TABLA	INDEX NO. POS. N. INDICE	DISEGNO DRAWING DESSIN ZEICHNUNG DIBUJO	TAVOLA DRAWING TABLE BILD TABLA	INDEX NO. POS. N. INDICE	DISEGNO DRAWING DESSIN ZEICHNUNG DIBUJO	TAVOLA DRAWING TABLE BILD TABLA	INDEX NO. POS. N. INDICE	DISEGNO DRAWING DESSIN ZEICHNUNG DIBUJO	TAVOLA DRAWING TABLE BILD TABLA	INDEX NO. POS. N. INDICE	DISEGNO DRAWING DESSIN ZEICHNUNG DIBUJO	TAVOLA DRAWING TABLE BILD TABLA	INDEX NO. POS. N. INDICE
1511 33302	16A	22	60N4 01050	21	14	8000 02124	5	22	8000 22551	18	3	8000 35780	8	23
1513 07001	14	25	60N4 95615	25	14	8000 02709	3A	22	8000 22966	22A	23	8000 35780	8A	23
1513 41401	21	12	61N1 15032	3	30	8000 02709	10	25	8000 23110	9A	25	8000 35781	3	33
1513 74301	21	17	61N1 15191	27	18	8000 02709	10A	25	8000 24952	5	4	8000 35781	3A	37
1514 10702	21	15	61N1 15192	24	17	8000 06597	5	8	8000 25044	8	16	8000 35781	8	24
1515 50601	16	32	61N1 15192	27	23	8000 06597	6	2	8000 25044	8A	16	8000 35781	8A	24
1517 54001	27	13	62N1 15503	3	10	8000 06597	6A	2	8000 25053	24	9	8000 36137	16	40
1519 84701	1	9	62N1 15504	2	26	8000 07719	5	15	8000 25572	9	9	8000 36137	16	40
1519 88201	1	8	62N1 15504	11	9	8000 07989	9	25	8000 26694	27	12	8000 36230	25	9
1610 82301	5	33	62N1 15504	14	49	8000 08536	16	55	8000 27521	2	27	8000 36380	3	26
1617 95501	2A	15	62N1 15535	3	11	8000 09671	7	29	8000 27521	2A	27	8000 36380	3A	3
60N1 01059	16	67	62N1 15547	13	15	8000 10777	23	3	8000 27690	9	10	8000 36440	5	5
60N1 01077	5	10	62N1 15547	25	44	8000 10904	9	29	8000 27690	9A	6	8000 36467	20	9
60N1 01079	10	23	62N1 15548	27	17	8000 11524	6	19	8000 27960	6	12	8000 36726	26	9
60N1 01079	10A	23	62N1 15549	13	10	8000 11524	6A	19	8000 27960	6A	12	8000 36786	6	11
60N1 01081	8	1	62N2 15504	6	15	8000 13346	22A	3	8000 28327	7	13	8000 36786	6A	11
60N1 01081	10	28	64N1 20048	14	50	8000 17040	10	2	8000 30728	5	3	8000 36856	8	9
60N1 01219	15	62	64N1 20068	14	12	8000 17040	10A	2	8000 31695	7	18	8000 36856	8	13
60N1 01883	7	21	64N1 20068	18	7	8000 17810	16	21	8000 31717	5	12	8000 36856	8A	9
60N1 02482	3	12	65N0 21002	11	4	8000 17826	2	4	8000 31748	3	22	8000 36856	8A	13
60N1 02483	3	14	65N0 21010	8	15	8000 17826	2A	4	8000 31748	6	6	8000 36857	8	10
60N1 02483	3	17	65N0 21010	8A	15	8000 18048	25	17	8000 31772	9	6	8000 36857	8A	10
60N1 02487	3	28	66N0 21202	7	28	8000 18246	25	13	8000 31772	9A	5	8000 36888	9	18
60N1 02506	2A	39	66N0 21202	10	17	8000 18422	2	33	8000 31773	7	15	8000 36888	9A	15
60N1 02506	6	26	66N0 21202	10A	17	8000 19177	6A	7	8000 32069	7	8	8000 37599	26	16
60N1 02509	2	25	66N0 21205	7	17	8000 19620	6	21	8000 32203	7	26	8000 37745	20	15
60N1 02509	6	10	66N0 21207	7	6	8000 19620	6A	21	8000 32388	16	56	8000 37906	13	12
60N1 02509	6	18	66N0 21208	7	11	8000 19965	4	6	8000 32389	5	16	8000 38110	7	23
60N1 02511	6	3	66N0 21209	9A	10	8000 19965	4A	6	8000 33372	14	14	8000 38210	24	27
60N1 02512	5	26	66N0 21211	9A	23	8000 19979	5	31	8000 33373	14	20	8000 38215	6	5
60N1 02514	5	25	66N0 21270	22A	22	8000 20137	27	32	8000 34002	27	36	8000 38215	6A	5
60N1 02515	4	7	66N0 21272	23	24	8000 20474	7	20	8000 34083	4	3	8000 38291	11	9
60N1 02515	5	24	69N4 29004	22A	9	8000 20536	16	14	8000 34083	4A	3	8000 38350	8	8
60N1 02558	2	14	69N4 29005	23	7	8000 20602	24	20	8000 34292	3	2	8000 38350	8A	8
60N1 02870	3	4	6BN0 21507	7	25	8000 21375	3A	7	8000 34451	6	8	8000 38518	5	19
60N1 04134	20	2	6BN0 21508	8	18	8000 21480	18	25	8000 34451	6A	8	8000 38521	16A	12
60N1 07335	2	34	6BN0 21508	8A	18	8000 21480	22	24	8000 35531	14	34	8000 38622	7	27
60N1 07335	6	14	8000 01199	20	17	8000 21480	22	24	8000 35620	3	3	8000 38623	7	30
60N1 15033	8	26	8000 01261	10	8	8000 21480	27	6	8000 35751	4	21	8000 38624	2	18
60N1 15033	8A	26	8000 01412	16	6	8000 21811	11	6	8000 35751	4A	21	8000 38624	2A	18
60N1 15533	2	23	8000 01412	16A	13	8000 22373	9	21	8000 35780	3	32	8000 38624	7	12
60N2 02489	3	27	8000 01688	23	3	8000 22373	9A	20	8000 35780	3A	36	8000 38706	10	3

DISEGNO DRAWING DESSIN ZEICHNUNG DIBUJO	TAVOLA DRAWING TABLE BILD TABLA	INDEX NO. POS. N.	DISEGNO DRAWING DESSIN ZEICHNUNG DIBUJO	TAVOLA DRAWING TABLE BILD TABLA	INDEX NO. POS. N.	DISEGNO DRAWING DESSIN ZEICHNUNG DIBUJO	TAVOLA DRAWING TABLE BILD TABLA	INDEX NO. POS. N.	DISEGNO DRAWING DESSIN ZEICHNUNG DIBUJO	TAVOLA DRAWING TABLE BILD TABLA	INDEX NO. POS. N.	DISEGNO DRAWING DESSIN ZEICHNUNG DIBUJO	TAVOLA DRAWING TABLE BILD TABLA	INDEX NO. POS. N.
8000 38706	10A	3	8000 42643	5	20	8000 47496	10A	5	8000 48814	19	23	8000 56359	26	29
8000 38707	10	4	8000 42700	9	24	8000 47678	6A	6	8000 48856	5	27	8000 56377	3A	8
8000 38707	10A	4	8000 42926	25	27A	8000 48110	7	1	8000 48916	17	16	8000 56377	18	6
8000 38711	10	13	8000 42946	25	6	8000 48111	7	2	8000 48917	17	5	8000 56381	20	7
8000 38711	10A	13	8000 43391	14	29	8000 48112	7	3	8000 48966	17	24	8000 56409	5	13
8000 38712	10	14	8000 43592	20	18	8000 48113	7	4	8000 49016	5	28	8000 56443	15	72
8000 38712	10A	14	8000 43720	1	4	8000 48114	7	5	8000 49036	22A	4	8000 56443	24	11
8000 38721	10	21	8000 43789	5	30	8000 48115	7	7	8000 49654	22	16	8000 56443	27	26
8000 38721	10A	21	8000 43823	1	13	8000 48116	7	9	8000 49967	11	3	8000 56444	25	29
8000 38728	10	12	8000 43824	1	5	8000 48117	7	10	8000 50005	20	27	8000 56444	27	35
8000 38728	10A	12	8000 43928	14	30	8000 48122	7	24	8000 50559	3	31	8000 56462	4	17
8000 38748	20	16	8000 43928	14	31	8000 48124	10A	1	8000 50569	24	30	8000 56462	4A	17
8000 38767	16A	23	8000 43928	16	37	8000 48125	10A	9	8000 50619	9	26	8000 56767	23	28
8000 38797	17	12	8000 43928	16	61	8000 48127	10	11	8000 50620	9	26	8000 56920	1	23
8000 39248	8	2	8000 43928	23	18	8000 48127	10A	11	8000 50629	2	3	8000 57019	3	5
8000 39335	2	36	8000 44240	11	14	8000 48128	10	15	8000 50629	2A	3	8000 57022	3	7
8000 39335	2A	36	8000 44240	16	33	8000 48128	10A	15	8000 50798	17	10	8000 57024	3	8
8000 39524	1	7	8000 44240	16	63	8000 48134	10	1	8000 50808	25	20	8000 57155	18	24
8000 39651	22A	13	8000 44240	21	10	8000 48135	10	9	8000 51957	22A	15	8000 57155	18	26
8000 40717	25	43	8000 44240	25	18	8000 48138	8	4	8000 52545	3	9	8000 57155	22	23
8000 40718	13	8	8000 44240	26	4	8000 48138	8A	4	8000 53155	15	61	8000 57155	22	23
8000 40718	25	34	8000 44978	6	4	8000 48168	9	28	8000 53259	18	29	8000 57155	27	5
8000 40813	20	21	8000 44978	6A	4	8000 48188	8	22	8000 53259	22	20	8000 57205	4	27
8000 41240	20	20	8000 45022	6	22	8000 48188	8A	22	8000 53340	6	23	8000 57205	4A	27
8000 41459	14	48	8000 45022	6A	22	8000 48209	5	21	8000 53340	6A	23	8000 57511	26	1
8000 41862	27	16	8000 45490	19	2	8000 48212	5	6	8000 53504	22A	6	8000 57542	7	14
8000 41863	27	15	8000 45495	16	35	8000 48216	6	9	8000 53876	7	31	8000 57789	10	22
8000 42022	14	33	8000 45495	18	33	8000 48216	6A	9	8000 54073	23	4	8000 57789	10A	22
8000 42022	16A	16	8000 45495	20	10	8000 48231	8	30	8000 54477	8	11	8000 58046	3	20
8000 42022	16B	31	8000 45499	21	25	8000 48234	8	29	8000 54477	8A	11	8000 58048	3	18
8000 42023	11	5	8000 46225	10	18	8000 48234	8A	29	8000 54692	8	25	8000 58207	25	33
8000 42023	16A	15	8000 46225	10A	18	8000 48235	8	27	8000 54692	8A	25	8000 58256	1	2
8000 42023	16A	17	8000 46226	10A	19	8000 48235	8A	27	8000 54899	3A	9	8000 58258	1	3
8000 42100	5	9	8000 46412	1	6	8000 48236	8	28	8000 55532	8	21	8000 58394	6A	29
8000 42155	5	2	8000 46613	1	1	8000 48236	8A	28	8000 55532	8A	21	8000 58929	23	5
8000 42185	5	14	8000 46860	5	7	8000 48238	8	14	8000 55536	7	19	8000 59289	16	24
8000 42244	5	29	8000 46881	4	19	8000 48238	8A	14	8000 55860	23	5	8000 59433	14	38
8000 42278	3A	10	8000 46881	4A	19	8000 48239	8	17	8000 55878	23	15	8000 59434	14	40
8000 42349	18	21	8000 46893	19	5	8000 48239	8A	17	8000 55902	18	4	8000 59603	6	25
8000 42487	10	24	8000 47160	10	7	8000 48772	22A	20	8000 55903	18	13	8000 59691	9	2
8000 42487	10A	24	8000 47496	10	5	8000 48773	22A	19	8000 56359	25	32	8000 59693	9	7

DISEGNO DRAWING DESSIN ZEICHNUNG DIBUJO	TAVOLA DRAWING TABLE BILD TABLA	INDEX NO. POS. N. INDICE	DISEGNO DRAWING DESSIN ZEICHNUNG DIBUJO	TAVOLA DRAWING TABLE BILD TABLA	INDEX NO. POS. N. INDICE	DISEGNO DRAWING DESSIN ZEICHNUNG DIBUJO	TAVOLA DRAWING TABLE BILD TABLA	INDEX NO. POS. N. INDICE	DISEGNO DRAWING DESSIN ZEICHNUNG DIBUJO	TAVOLA DRAWING TABLE BILD TABLA	INDEX NO. POS. N. INDICE	DISEGNO DRAWING DESSIN ZEICHNUNG DIBUJO	TAVOLA DRAWING TABLE BILD TABLA	INDEX NO. POS. N. INDICE
8000 59694	9	13	8000 62152	9	12	8000 62729	15	40	8000 64988	4A	33	8000 69429	19	21
8000 59695	9	27	8000 62153	9	16	8000 62729	19	32	8000 65411	16	31	8000 69429	19	22
8000 59696	9	15	8000 62154	9	17	8000 62729	22	37	8000 65412	16	9	8000 69429	20	23
8000 59697	9	14	8000 62341	21	1	8000 62729	25	36	8000 65437	17	21	8000 69434	14	6
8000 59699	9	20	8000 62651	24	8	8000 62730	3A	21	8000 65442	23	27	8000 69549	13	2
8000 59801	4	15	8000 62675	14	55	8000 62730	21	9	8000 65464	23	28	8000 69750	3A	27
8000 59801	4A	15	8000 62676	14	54	8000 62730	25	19	8000 66238	20	3	8000 70024	13	7
8000 59803	4	12	8000 62725	4A	34	8000 62731	16	29	8000 66279	21	7	8000 70206	11	10
8000 59803	4A	12	8000 62725	11	13	8000 62731	16	62	8000 66473	2	31	8000 70215	10	16
8000 59843	4	1	8000 62725	16	64	8000 62732	14	51	8000 66651	14	47	8000 70215	10A	7
8000 59843	4A	1	8000 62725	18	18	8000 62733	15	65	8000 66652	14	45	8000 70216	10	27
8000 59844	4	2	8000 62725	21	8	8000 62733	22	12	8000 66802	1	17	8000 70216	10A	8
8000 59844	4A	2	8000 62725	25	46	8000 62795	14	8	8000 67997	3A	26	8000 70217	10	29
8000 59845	4	4	8000 62726	13	9	8000 62795	16	36	8000 67997	15	68	8000 70217	10A	27
8000 59845	4A	4	8000 62726	16B	24	8000 62796	14	19	8000 67997	16	14	8000 70222	2	7
8000 59856	4	5	8000 62726	18	12	8000 62796	15	2	8000 67997	16	23	8000 70223	2	6
8000 59913	8	19	8000 62726	18	34	8000 63312	14	39	8000 67997	16	23	8000 70266	18	20
8000 60033	24	26	8000 62726	24	14	8000 63312	16	54	8000 68516	15	64	8000 70277	25	3
8000 60233	15	59	8000 62727	3A	30	8000 63339	2	2	8000 68690	25	45	8000 70280	25	22A
8000 60234	15	60	8000 62727	6A	14	8000 63389	8	12	8000 68805	2	11	8000 70282	25	24A
8000 60404	18	19	8000 62727	11	2	8000 63583/1	2	9	8000 68816	3	21	8000 70638	18	31
8000 60404	22	19	8000 62727	11	15	8000 63583/2	2	9	8000 69035	20	26	8000 70642	3	24
8000 60464	9A	24	8000 62727	19	11	8000 63583/3	2	9	8000 69036	20	5	8000 70667	2	24
8000 60516	1	1	8000 62727	19	14	8000 63584	2	8	8000 69056	14	3	8000 70696	18	5
8000 60873	4	28	8000 62727	20	24	8000 63590	2	30	8000 69056	14	51	8000 70698	17	18
8000 60873	4A	28	8000 62727	25	31	8000 63594	2	17	8000 69111	14	21	8000 70836	1	16
8000 60944	9A	3	8000 62728	3A	16	8000 63623	9	1	8000 69113	21	4	8000 71086	14	37
8000 60947	9A	7	8000 62728	6A	18	8000 63624	9	11	8000 69125	18	2	8000 71087	14	46
8000 60951	9A	17	8000 62728	6A	26	8000 63625	9	8	8000 69148	19	15	8000 71088	14	44
8000 60969	24	22	8000 62728	8A	1	8000 63626	9	22	8000 69149	19	7	8000 71091	14	22
8000 61068	17	22	8000 62728	10A	28	8000 63627	9	3	8000 69150	14	18	8000 71213	27	7
8000 61078	18	14	8000 62728	13	13	8000 63628	9	19	8000 69231	21	11	8000 71214	27	8
8000 61101	2	20	8000 62728	17	14	8000 63630	4	22	8000 69232	21	16	8000 71215	27	9
8000 61102	2	22	8000 62728	17	17	8000 63636	19	27	8000 69282	15	69	8000 71216	27	10
8000 61102	2A	22	8000 62728	19	18	8000 63828	9A	22	8000 69282	16	52	8000 71217	27	11
8000 61115	8	20	8000 62728	25	8	8000 63829	9A	22	8000 69315	15	57	8000 71221	27	31
8000 61115	8A	20	8000 62728	26	3	8000 63830	9A	22	8000 69372	6	16	8000 71230	8	3
8000 61313	19	4	8000 62728	26	10	8000 63885	2	35	8000 69372	6A	16	8000 71445	18	27
8000 61313	24	12	8000 62729	2A	25	8000 63885	2A	35	8000 69428	24	4	8000 71445	22	14
8000 61314	15	63	8000 62729	4	14	8000 64296	3	23	8000 69429	13	5	8000 71578	17	26
8000 61355	15	53	8000 62729	4A	14	8000 64296	6	7	8000 69429	16B	23	8000 71578	26	27
8000 61376	10	19	8000 62729	6A	10	8000 64868	9	23	8000 69429	19	17	8000 71620	16	13

DISEGNO DRAWING DESSIN ZEICHNUNG DIBUJO	TAVOLA DRAWING TABLE BILD TABLA	INDEX NO. POS. N.	DISEGNO DRAWING DESSIN ZEICHNUNG DIBUJO	TAVOLA DRAWING TABLE BILD TABLA	INDEX NO. POS. N.	DISEGNO DRAWING DESSIN ZEICHNUNG DIBUJO	TAVOLA DRAWING TABLE BILD TABLA	INDEX NO. POS. N.	DISEGNO DRAWING DESSIN ZEICHNUNG DIBUJO	TAVOLA DRAWING TABLE BILD TABLA	INDEX NO. POS. N.	DISEGNO DRAWING DESSIN ZEICHNUNG DIBUJO	TAVOLA DRAWING TABLE BILD TABLA	INDEX NO. POS. N.
8000 71621	16	53	8000 73443	3	25	8000 77827	27	19	8000 85998	22	11	8000 86885	9A	2
8000 71622	16	2	8000 73458	14	27	8000 77884	22A	14	8000 85999	22	18	8000 86886	9A	9
8000 71623	16	19	8000 73500	5	11	8000 77980	18	23	8000 86136	16A	5	8000 86887	4A	22
8000 71806	22	10	8000 73505	2	1	8000 78788	5	17	8000 86136	16A	19	8000 86888	13	6
8000 72022	22	13	8000 73540	11	5	8000 78788	5	17	8000 86137	16A	20	8000 86899	9A	1
8000 72168	16A	21	8000 73591	26	7	8000 79065	22	21	8000 86140	16A	18	8000 86901	9A	9
8000 72311	12	3	8000 73592	26	28	8000 79066	18	22	8000 86176	16A	3	8000 86902	2A	11
8000 72318	12	17	8000 73593	11	8	8000 79066	22	22	8000 86176	16A	10	8000 86907	12	1
8000 72318	12	20	8000 73834	25	35	8000 79069	22	4	8000 86177	16A	7	8000 86918	12	2
8000 72320	12	18	8000 73988	12	1	8000 79070	22	5	8000 86177	16A	26	8000 86919	12	4
8000 72322	12	19	8000 74016	16	65	8000 79072	18	16	8000 86806/1	2A	9	8000 86920	12	5
8000 72323	12	7	8000 74258	24	25	8000 79075	18	28	8000 86806/2	2A	9	8000 86921	12	6
8000 72323	12	9	8000 74259	24	24	8000 79077	4	10	8000 86806/3	2A	9	8000 86925	12	10
8000 72324	12	8	8000 74261	3	29	8000 79077	4A	10	8000 86817	2A	7	8000 86926	12	11
8000 72325	12	9	8000 74287	27	46	8000 79096	22	2	8000 86819	2A	8	8000 86927	12	12
8000 72326	12	10	8000 74870	3	1	8000 79097	22	3	8000 86823	2A	12	8000 86928	12	16
8000 72327	12	11	8000 75160	16	51	8000 79098	22	6	8000 86825	2A	19	8000 86929	12	22
8000 72327	12	13	8000 75166	16	39	8000 79099	22	7	8000 86827	2A	20	8000 86930	12	23
8000 72328	12	12	8000 75270	11	11	8000 79100	22	9	8000 86828	2A	21	8000 86932	12	7
8000 72328	12	14	8000 75330	17	4	8000 79789	23	28	8000 86840	3A	5	8000 86933	12	21
8000 72329	12	13	8000 75343	11	17	8000 79790	23	28	8000 86843	3A	6	8000 86978	12	8
8000 72329	12	15	8000 75344	11	1	8000 80145	11	20	8000 86844	3A	23	8000 86979	12	18
8000 72330	12	14	8000 75345	11	17	8000 80260	15	54	8000 86846	3A	17	8000 86980	10	10
8000 72331	12	15	8000 75346	11	7	8000 80262	27	14	8000 86847	3A	14	8000 86980	10A	10
8000 72331	12	17	8000 75348	25	26	8000 80901	27	40	8000 86848	3A	25	8000 86983	9A	7
8000 72333	12	6	8000 75477	24	23	8000 80902	27	41	8000 86849	3A	19	8000 86984	9A	8
8000 72334	12	16	8000 75549	25	42	8000 80904	27	42	8000 86850	3A	20	8000 86985	9A	11
8000 72494	25	4	8000 75578	1	10	8000 82496	11	2	8000 86851	2A	24	8000 86986	9A	13
8000 72522	5	23	8000 75579	1	10	8000 82928	9A	19	8000 86857	2A	37	8000 86987	9A	16
8000 72641	13	3	8000 76016	11	10	8000 82929	9A	13	8000 86858	2A	38	8000 86988	9A	17
8000 72868	16	58	8000 76283	16	11	8000 82931	9A	18	8000 86860	8A	12	8000 86990	9A	8
8000 72869	16	59	8000 76284	17	7	8000 82939	6A	13	8000 86862	8A	30	8000 86991	9A	16
8000 72873	16	57	8000 76289	18	32	8000 82943	3A	18	8000 86864	3A	28	8000 86992	9A	3
8000 72874	16	28	8000 76338	18	10	8000 83395	15	3	8000 86865	3A	29	8000 86993	9A	18
8000 72875	16	27	8000 76687	17	3	8000 83590	5	3	8000 86866	3A	31	8000 86994	9A	11
8000 72887	11	7	8000 76688	17	2	8000 83590	5	18	8000 86867	3A	32	8000 86995	9A	12
8000 73140	14	5	8000 77373	15	20	8000 84176	14	56	8000 86868	3A	33	8000 87086	24	2
8000 73141	15	58	8000 77699	22A	18	8000 84938	22A	13	8000 86872	5	1	8000 87088	24	21
8000 73356	2	12	8000 77737	17	11	8000 85220	17	23	8000 86878	6A	25	8000 87153	18	17
8000 73370	3	13	8000 77749	22A	5	8000 85390	8A	7	8000 86880	8A	3	8000 87243	14	25
8000 73371	3	16	8000 77827	24	6	8000 85932	18	30	8000 86884	9A	1	8000 87562	25	22

DISEGNO DRAWING DESSIN ZEICHNUNG DIBUJO	TAVOLA DRAWING TABLE BILD TABLA	INDEX NO. POS. N. INDICE	DISEGNO DRAWING DESSIN ZEICHNUNG DIBUJO	TAVOLA DRAWING TABLE BILD TABLA	INDEX NO. POS. N. INDICE	DISEGNO DRAWING DESSIN ZEICHNUNG DIBUJO	TAVOLA DRAWING TABLE BILD TABLA	INDEX NO. POS. N. INDICE	DISEGNO DRAWING DESSIN ZEICHNUNG DIBUJO	TAVOLA DRAWING TABLE BILD TABLA	INDEX NO. POS. N. INDICE	DISEGNO DRAWING DESSIN ZEICHNUNG DIBUJO	TAVOLA DRAWING TABLE BILD TABLA	INDEX NO. POS. N. INDICE
8000 87736	15	56	8000 89915	22	8	8000 92308	17	9	8000 94239	29	9	8000 97034	15	50
8000 87745	15	73	8000 89915	27	28	8000 92414	23	9	8000 94240	28	8	8000 97035	15	49
8000 87765	2A	6	8000 89919	26	17	8000 92693	22A	8	8000 94240	29	8	8000 97036	16	1
8000 87810	16	10	8000 89920	26	17	8000 92703	23	6	8000 94342	25	37	8000 97038	16B	1
8000 87812	17	15	8000 89954	2A	31	8000 92788	21	6	8000 94595	25	30	8000 97039	29	1
8000 87847	24	7	8000 89957	3A	12	8000 92790	22A	11	8000 94849	18	26	8000 97143	2A	29
8000 87849	24	3	8000 89996	7	22	8000 92792	22A	21	8000 94853	2A	28	8000 97145	2A	29
8000 87880	2	10	8000 89998	7	24	8000 92797	22A	12	8000 94854	2A	32	8000 97148	15	50
8000 88139	25	28	8000 90012	11	12	8000 92797	23	11	8000 94855	2	28	8000 97149	15	49
8000 88231	16B	21	8000 90027	21	2	8000 93009	21	3	8000 94856	2	32	8000 97151	16	1
8000 88280	17	1	8000 90031	21	3	8000 93011	26	30	8000 95243	8	5	8000 97152	16B	1
8000 88280	17	1	8000 90048	23	6	8000 93017	20	12	8000 95248	22	15	8000 97153	28	1
8000 88334	26	25	8000 90104	22	13	8000 93023	21	3	8000 95260	15	41	8000 97153	29	1
8000 88335	26	26	8000 90107	24	19	8000 93036	22	8	8000 95415	19	33	8000 97155	28	1
8000 88336	26	6	8000 90197	25	22	8000 93072	23	21	8000 95416	19	34	8000 97155	29	1
8000 88337	26	11	8000 90561	16A	24	8000 93109	22	1	8000 95648	25	27	8000 97233	2A	10
8000 88538	27	2	8000 90617	7	1	8000 93124	16A	6	8000 95649	25	24	8000 97234	2A	13
8000 88602	27	4	8000 90659	1	12	8000 93283	15	70	8000 95650	25	48	8000 97252	3A	11
8000 88603	27	3	8000 90710	17	7	8000 93746	17	20	8000 95898	13	4	8000 97299	1	19
8000 88862	20	1	8000 91238	16B	4	8000 93747	17	19	8000 96811	15	1	8000 97300	1	20
8000 88862	20	1	8000 91288	1	14	8000 93748	17	27	8000 96813	15	4	8000 97301	1	22
8000 88863	18	23	8000 91289	1	15	8000 93749	17	28	8000 96828	17	25	8000 97560	21	2
8000 88865	17	6	8000 91474	15	13	8000 93750	17	13	8000 96838	22A	10	8000 97615	24	29
8000 88866	19	9	8000 91479	15	19	8000 93751	17	8	8000 96897	15	4	8000 97749	15	77
8000 88867	19	10	8000 91480	15	48	8000 93752	17	29	8000 96907	14	11	8000 97750	15	76
8000 88868	20	6	8000 91506	15	6	8000 93883	20	11	8000 96908	14	11	8000 97819	27	1
8000 88869	20	22	8000 91507	15	5	8000 94009	20	19	8000 96922	16A	1	8000 97831	1	21
8000 88873	25	11	8000 91519	15	55	8000 94010	20	13	8000 96923	16A	2	8000 97856	28	2
8000 88882	22A	10	8000 91535	14	2	8000 94098	20	8	8000 96928	22A	11	8000 97856	29	2
8000 88884	22A	16	8000 91610	15	21	8000 94117	4	18	8000 96930	22A	21	8000 97857	28	3
8000 88887	23	14	8000 91719	3A	35	8000 94117	4A	18	8000 96932	22A	18	8000 97858	28	4
8000 88889	22A	23	8000 91839	27	29	8000 94119	25	12	8000 96933	22A	19	8000 97858	29	4
8000 88966	8A	5	8000 91952	11	1	8000 94120	25	16	8000 96937	23	8	8000 97859	28	5
8000 88969	10	26	8000 91953	11	17	8000 94121	25	15	8000 96938	23	12	8000 97859	29	5
8000 88969	10A	26	8000 91957	25	2	8000 94124	22	2	8000 96940	23	19	8000 97976	14	53
8000 88988	2	29	8000 91964	27	30	8000 94125	22	3	8000 96941	16	50	8000 98040	14	52
8000 89024	2A	1	8000 92149	26	17	8000 94126	22	4	8000 96944	16	18	8000 98489	16B	5
8000 89089	16B	11	8000 92215	4	8	8000 94127	22	5	8000 96945	19	1	8000 98490	16B	7
8000 89353	6	28	8000 92215	4A	8	8000 94128	22	6	8000 96946	19	24	8000 98491	16B	8
8000 89353	6A	28	8000 92216	4	9	8000 94129	22	9	8000 96960	16	3	8000 98492	16B	9
8000 89368	5	1	8000 92216	4A	9	8000 94213	29	3	8000 96997	1	18	8000 98493	16B	10
8000 89572	23	26	8000 92225	3A	24	8000 94239	28	9	8000 97025	16	66	8000 98494	16B	12

DISEGNO DRAWING DESSIN ZEICHNUNG DIBUJO	TAVOLA DRAWING TABLE BILD TABLA	INDEX NO. POS. N.	DISEGNO DRAWING DESSIN ZEICHNUNG DIBUJO	TAVOLA DRAWING TABLE BILD TABLA	INDEX NO. POS. N.	DISEGNO DRAWING DESSIN ZEICHNUNG DIBUJO	TAVOLA DRAWING TABLE BILD TABLA	INDEX NO. POS. N.	DISEGNO DRAWING DESSIN ZEICHNUNG DIBUJO	TAVOLA DRAWING TABLE BILD TABLA	INDEX NO. POS. N.	DISEGNO DRAWING DESSIN ZEICHNUNG DIBUJO	TAVOLA DRAWING TABLE BILD TABLA	INDEX NO. POS. N.
8000 98495	16B	20	80A0 88856	19	12	8A00 48239	8	17	8A00 75556	12	5	8B00 40796	23	17
8000 98496	16B	15	80A0 88877	20	1	8A00 48239	8A	17	8A00 76026	18	9	8B00 43715	4	11
8000 98497	16B	16	80A0 88927	19	12	8A00 50632	2A	2	8A00 77745	18	15	8B00 43715	4A	11
8000 98498	16B	17	80A0 89953	14	9	8A00 54319	9	5	8A00 79072	18	16	8B00 48239	8	17
8000 98499	16B	18	80A0 89962	14	10	8A00 54319	9A	4	8A00 79783	23	27	8B00 48239	8A	17
8000 98500	16B	2	80A0 91792	13	1	8A00 55241	18	11	8A00 79785	27	23	8B00 57027	3	6
8000 98501	16B	13	80A0 94221	28	7	8A00 55241	22A	17	8A00 82467	8A	6	8B00 57446	11	10
8000 98502	16B	14	80A0 94221	29	7	8A00 56768	23	27	8A00 86138	16A	4	8B00 60278	2	19
8000 98503	16B	19	80A0 94222	28	6	8A00 57002	6	13	8A00 86176	16A	11	8B00 63593	2	16
8000 98507	16B	3	80A0 94222	29	6	8A00 59913	8A	19	8A00 86845	3A	13	8B00 66525	15	71
8000 98510	16B	3	80C0 53018	17	1	8A00 62797	14	4	8A00 86902	2A	11	8B00 66525	24	13
8000 98552	15	22	80C0 69337	15	66	8A00 62797	16B	30	8A00 86918	12	2	8B00 66525	24	16
8000 98569	16B	6	80C0 69338	15	67	8A00 63593	2A	16	8A00 86919	12	4	8B00 66525	27	22
8000 98570	16B	6	80C0 69981	15	51	8A00 63842	21	19	8A00 86920	12	5	8B00 66525	27	25
8000 98782	15	78	80C0 87060	25	25	8A00 65503	15	56	8A00 87717	15	3	8B00 67545	4A	7
8000 98783	15	79	80D0 73395	19	3	8A00 66661	16	34	8A00 87810	16	10	8B00 68805	2	11
8000 98784	15	80	80D0 96951	28	10	8A00 67545	6A	3	8A00 88603	27	3	8B00 69282	19	26
8000 98785	15	81	80D0 96951	29	10	8A00 67545	20	4	8A00 92986	22A	15	8B00 69429	25	10
8000 98786	15	6	80E0 96951	29	10	8A00 67997	15	52	8A00 93011	26	31	8B00 71759	27	20
8000 98787	15	5	80F0 96951	28	10	8A00 67997	16	23	8A00 96811	15	1	8B00 72311	12	3
8000 98791	15	21	80F0 96951	29	10	8A00 68805	2	11	8A00 96837	23	16	8B00 72312	12	2
8000 98792	15	22	8A00 01261	10	8	8A00 69003	19	28	8A00 97029	14	1	8B00 86902	2A	11
8000 98806	15	41	8A00 01815	14	13	8A00 69056	16	60	8A00 97069	14	1	8B00 86918	12	2
80A0 42349	20	14	8A00 10350	2	15	8A00 69282	16	26	8A00 97560	21	2	8B00 86919	12	4
80A0 60288	6	1	8A00 20373	25	1	8A00 69315	15	57	8A00 97977	14	53	8B00 86920	12	5
80A0 63618	6	24	8A00 22551	3A	34	8A00 69546	13	6	8AA0 55705	4A	29	8B00 88899	21	5
80A0 67248	4	25	8A00 23109	3A	2	8A00 69786	7	22	8AA0 55705	25	50	8B00 96837	23	16
80A0 67248	4A	25	8A00 26846	23	20	8A00 70381	2	21	8AA0 55705	27	27	8B00 97560	21	2
80A0 69144	6	17	8A00 28327	5	20	8A00 72311	12	3	8AA0 65340	24	1	8C00 01261	10	8
80A0 69551	16B	22	8A00 30729	2	5	8A00 72334	12	19	8AA0 65340	27	21	8C00 10350	2	15
80A0 70581	24	15	8A00 30729	2A	5	8A00 73340	4	20	8B00 01261	10	8	8C00 36022	9	30
80A0 70581	27	24	8A00 31970	21	26	8A00 73340	4A	20	8B00 06725	6	20	8C00 36022	9	31
80A0 73426	16	16	8A00 36889	9	4	8A00 73343	18	1	8B00 06725	6A	20	8C00 43716	4	16
80A0 73456	16	15	8A00 36889	9A	14	8A00 73440	3	15	8B00 07989	9	25	8C00 43716	4A	16
80a0 74373	27	45	8A00 37947	13	11	8A00 73441	3	19	8B00 10350	2	15	8C00 61121	16	20
80A0 74388	16	22	8A00 38110	7	16	8A00 73458	14	28	8B00 10904	9	29	8C00 67997	19	25
80A0 82930	6A	17	8A00 38708	10	6	8A00 73541	21	30	8B00 26846	23	10	8C00 68805	2	11
80A0 82940	4A	5	8A00 38708	10A	6	8A00 74181	22	17	8B00 36022	9	31	8C00 70379	21	13
80A0 86875	6A	1	8A00 39248	8A	2	8A00 75160	14	57	8B00 38110	7	16	8C00 71759	24	5
80A0 86877	6A	24	8A00 44117	2A	17	8A00 75329	21	18	8B00 38110	7	23	8C00 72311	12	3
80A0 87800	19	29	8A00 48137	8	7	8A00 75347	11	1	8B00 38752	20	25	8C00 72312	12	2

DISEGNO DRAWING DESSIN ZEICHNUNG DIBUJO	TAVOLA DRAWING TABLE BILD TABLA	INDEX NO. POS. N. INDICE	DISEGNO DRAWING DESSIN ZEICHNUNG DIBUJO	TAVOLA DRAWING TABLE BILD TABLA	INDEX NO. POS. N. INDICE	DISEGNO DRAWING DESSIN ZEICHNUNG DIBUJO	TAVOLA DRAWING TABLE BILD TABLA	INDEX NO. POS. N. INDICE	DISEGNO DRAWING DESSIN ZEICHNUNG DIBUJO	TAVOLA DRAWING TABLE BILD TABLA	INDEX NO. POS. N. INDICE	DISEGNO DRAWING DESSIN ZEICHNUNG DIBUJO	TAVOLA DRAWING TABLE BILD TABLA	INDEX NO. POS. N. INDICE
8C00 75556	12	5	8F00 72315	12	4									
8C00 77740	22	1	8G00 07989	9	25									
8C00 86138	16A	14	8G00 07989	9A	21									
8C00 86902	2A	11	8G00 10904	9	29									
8C00 86919	12	4	8G00 34292	3	2									
8C00 86920	12	5	8G00 36022	9	30									
8C00 96837	23	16	8H00 07989	9	25									
8C00 97069	14	1	8H00 10904	9	29									
8D00 01261	10	8	8H00 28183	5	32									
8D00 01261	10	20	8H00 36022	9	30									
8D00 01261	10A	20	8H00 67545	5	10									
8D00 07989	9	25	8H00 72315	12	4									
8D00 10904	9	29	8I00 07989	9	25									
8D00 32069	7	8	8I00 07989	9A	21									
8D00 36022	9	30	8I00 10904	9	29									
8D00 36022	9	31	8J00 36022	9	30									
8D00 38110	7	16	8K00 36022	9	30									
8D00 59802	4	13	8K00 69056	2A	14									
8D00 59802	4A	13	8K00 72315	12	4									
8D00 62797	16A	8	8M00 72315	12	4									
8D00 68805	2	11	8P00 72315	12	4									
8D00 70034	25	23	8S00 72310	12	3									
8D00 72311	12	3	8T00 72310	12	3									
8D00 72312	12	2	8T00 72310	12	3									
8D00 75556	12	5	8U00 72310	12	3									
8D00 86918	12	2	8U00 72310	12	3									
8D00 96837	23	16	8V00 72310	12	3									
8E00 07989	9	25	8V00 72310	12	3									
8E00 07989	9A	21	8W00 72310	12	3									
8E00 10904	9	29	8W00 72310	12	3									
8E00 32069	7	8	8X00 72310	12	3									
8E00 67545	2A	23	8X00 72310	12	3									
8E00 67997	6	27	8Y00 72310	12	3									
8E00 67997	6A	27	8Y00 72310	12	3									
8E00 72311	12	3	8Z00 72310	12	3									
8E00 72315	12	4	8Z00 72310	12	3									
8E00 75556	12	5												
8F00 07989	9	25												
8F00 10904	9	29												
8F00 34292	3	2												
8F00 36022	9	30												
8F00 67997	3A	15												